



MOUNTING BRACKET KIT INSTALLATION INSTRUCTIONS

KIT# 523182-5

02/25/16

Special Tools Needed

1½" hole saw

Important

Note: this bracket will not accommodate the Guardian rock shield, some models of the Tow Defender, Stowaway or the StowMaster and StowMaster All Terrain tow bars.

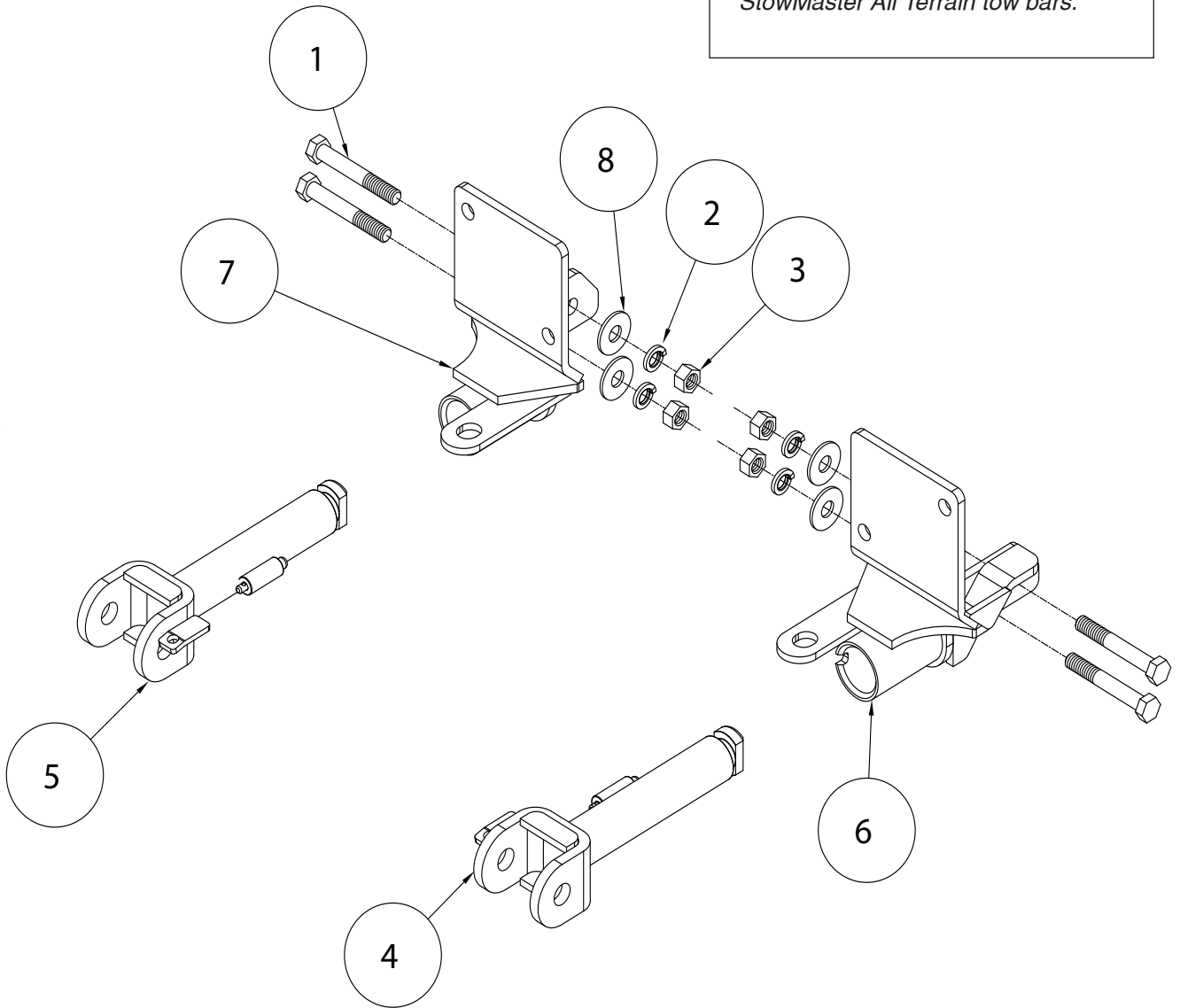

ITEM	QTY	NAME	PART #
1.....	4.....	1/2" x 3 1/2" BOLT	350103-00
2.....	4.....	1/2" LOCK WASHER.....	350309-00
3.....	4.....	1/2" HEX NUT.....	350258-00
4.....	1.....	DRIVER SIDE ARM	C-002383
5.....	1.....	PASSENGER SIDE ARM.....	C-002384
6.....	1.....	DRIVER SIDE RECEIVER.....	C-002843
7.....	1.....	PASSENGER SIDE RECEIVER	C-002844
8.....	4.....	1/2" FLAT WASHER	350308-00



MOUNTING BRACKET KIT INSTALLATION INSTRUCTIONS

KIT# 523182-5

02/25/16

This is one of our EZ5 Twistlock series brackets, which allows the visible front portion of the bracket to be easily removed from the front of the vehicle (Fig.A and Fig.B). The bracket consists of a main receiver brace, two removable front braces, and a hardware pack.

The main receiver brace mounts to the frame rails. The removable front braces install in the main receiver brace.

Before starting the installation, lay out the kit components in order, as they will be used. This will give you a visual idea of how the components work, and will also confirm that everything is present and accounted for.



Fig.A



Fig.B

IMPORTANT: All brackets *must* be assembled with all the bolts left loose for final adjustment and positioning (before tightening) unless otherwise instructed. All bolts *must* be torqued for proper strength. If more than one bolt is used per fastening point, the diagram may only show one.

- Use flat washers over all slotted holes
- Use lock washers on all fasteners

ROADMASTER Limited Warranty, including One-Year Conditional Warranty Text and Product Registration Card, in Carton.

WARNING

Failure to follow these instructions can result in property damage, personal injury or even death.

- Installation of most mounting brackets requires moderate mechanical aptitude and skills. We strongly recommend professional installation by an experienced installer.
- The installer must read the instructions and use all bolts and parts supplied. Failure to do so could result in loss of the towed vehicle.
- Use Loctite® Red on all bolts used for mounting this bracket.
- Every 3,000 miles, the owner must inspect the fasteners for proper torque, according to the bolt torque requirements chart on the last page of these instructions. The owner must also inspect all mounts and brackets for cracks or other signs of fatigue every 3,000 miles. Failure to do so could result in loss of the towed vehicle.
- The owner must check the vehicle manufacturer's instructions for the proper procedure(s) to prepare the vehicle for towing. Some vehicles must be equipped with a transmission lube pump, an axle disconnect, driveline disconnect or free-wheeling hubs before they can be towed. Failure to properly equip the vehicle will cause severe damage to the transmission.
- If running changes were made by the vehicle manufacturer after this bracket was designed, some bolts or other fasteners in the hardware pack may no longer be the correct size. It is the installer's responsibility to verify that the bracket is securely fastened to the vehicle and fitted with the correct hardware to account for these changes. Failure to securely fasten the bracket could result in loss of the towed vehicle.
- If the towed vehicle has been in an accident, it must be properly repaired before attaching the bracket. Do not install the bracket if any structural frame damage is found. Failure to repair the damage could result in the loss of the towed vehicle.

- Roadmaster manufactures many styles of brackets. If your bracket has removable arms, they must be removed before driving the vehicle, unless the arms can be pinned or padlocked in place. If not secured, the arms could vibrate out, resulting in non-warranty damage or personal injury.
- Some motorhome chassis have such a tight turning radius that you can damage your motorhome, towed vehicle, tow bar or bracket while turning sharply. Before getting on the road, test your turning radius in an empty parking lot. Turning too sharply could result in non-warranty damage to towing system, motorhome and/or towed vehicle.
- Do not back up with the towed vehicle attached or non-warranty damage will occur to your towing system, motorhome and/or towed vehicle.
- The safety cables must connect the towing vehicle to the towed vehicle frame to frame, with the cables crossed, with enough slack for sharp turns. Refer to the cable instructions for proper routing. Failure to leave enough slack in the safety cables, or failure to connect the safety cables frame to frame, will result in the loss of the towed vehicle.
- This bracket is designed for use with ROADMASTER tow bars and ROADMASTER adaptors only. Using this bracket with other brands, without an approved ROADMASTER adaptor, may result in non-warranty damage or injury.
- Do not use this document for custom fabrication, as it may not show all parts or structural components. Custom fabrication or an attempt to copy this bracket design could result in loss of the towed vehicle.
- Upon final installation, the installer must inspect the bracket to ensure adequate clearance, particularly around hoses, air conditioner lines, radiators, etc., or non-warranty damage to the towed vehicle will result.
- This bracket is only warranted for the original installation. Installing a used bracket on another vehicle is not recommended and will void the warranty.



MOUNTING BRACKET KIT INSTALLATION INSTRUCTIONS

KIT# 523182-5

02/25/16

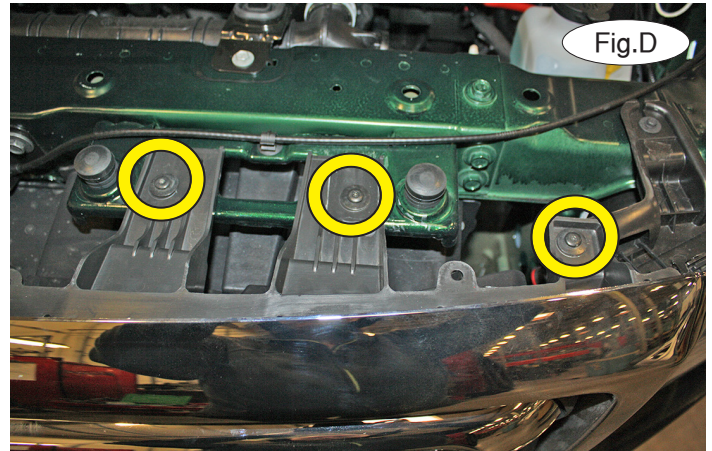
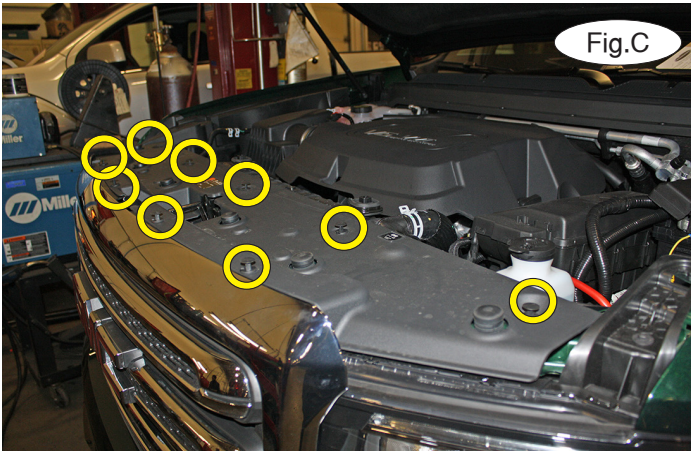

1. **Important:** please use all supplied bolts and parts and read all instructions carefully before beginning this installation. The majority of questions you may have can be answered within the text, and proper installation will ensure safe and secure travel. Now, begin the installation. **For Colorado models:** proceed to the next step. **For Canyon models:** remove nine plastic fasteners attaching the top of the radiator cover to the core support (Fig.C). Remove the radiator cover and set it aside for now.

2. On each side, remove three T15 Torx screws attaching the top of the fascia to the core support (Fig.D – driver's side). *Note:* Fig. D shows a Canyon. If you have a Colorado, it may look slightly different but the same fastener removal still applies.

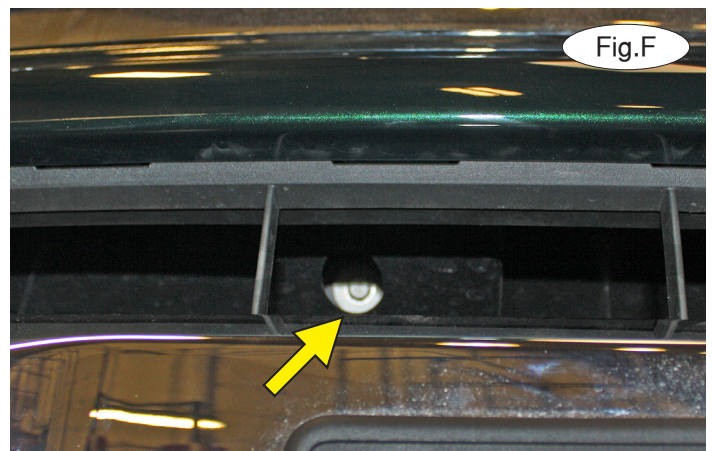
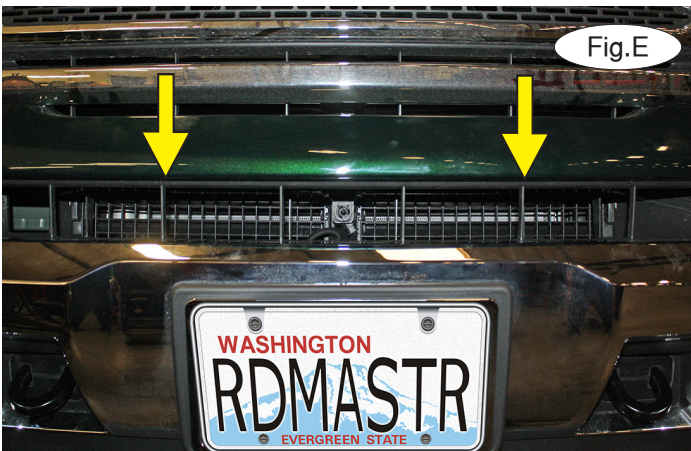

3. Locate the two spots indicated in Figure E. Place a 10mm extension through the center grille opening and remove two 10mm (head) bolts located above those two spots. Figure F shows the bolt head.

4. Remove four 15mm (head) bolts attaching the splash shielding to the frame (Fig.G).

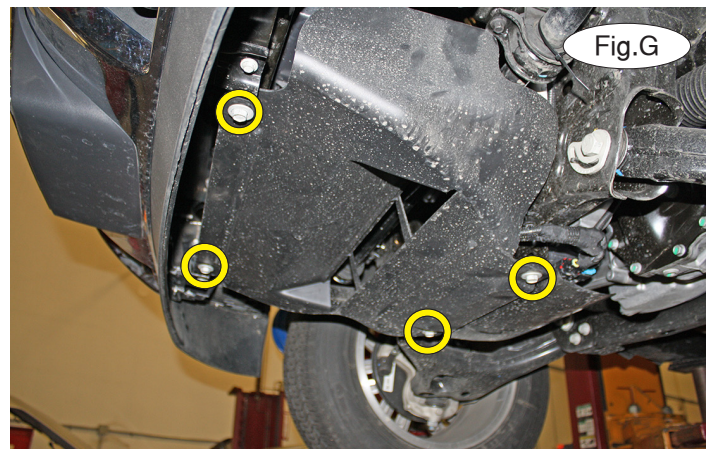



MOUNTING BRACKET KIT INSTALLATION INSTRUCTIONS

KIT# 523182-5

02/25/16



5. Remove two 10mm (head) bolts attaching the bottom of the fascia to the frame (Fig.H).

6. On each side, remove seven T15 Torx screws attaching the fender liner to the fascia (Fig.I and Fig.J). *Note:* if the vehicle is equipped with fender trim, some of these fasteners may be located under the trim and will need to be removed as well. Pull out the trim to locate them.



7. Pull out the fender liner and tuck it behind the tire. Disconnect the fog lights, if the vehicle is so equipped, and remove three 7mm (head) screws attaching the fender to the fascia (Fig.K).

8. On each side, pull down at the seam to release the aligning pins from the fascia (Fig.L).





MOUNTING BRACKET KIT INSTALLATION INSTRUCTIONS

KIT# 523182-5

02/25/16

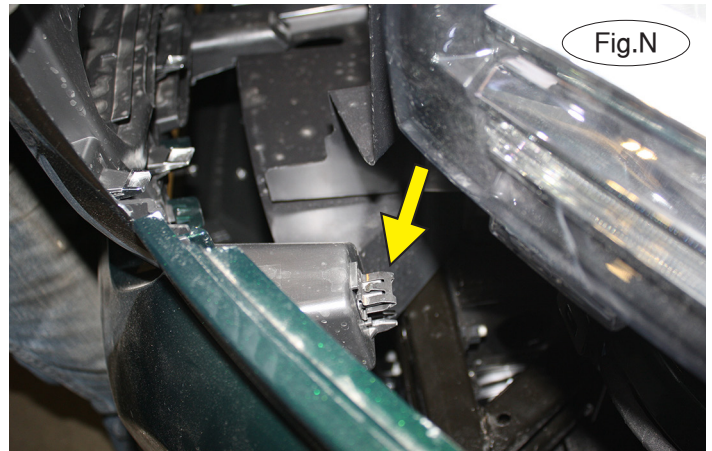

9. On each side, pull down to remove the fascia (Fig.M), releasing the clips on each side in the process (Fig.N).

10. Remove three plastic fasteners attaching the air dam to the frame rails (Fig.O) and on each side, one plastic clip (Fig.P – driver's side).

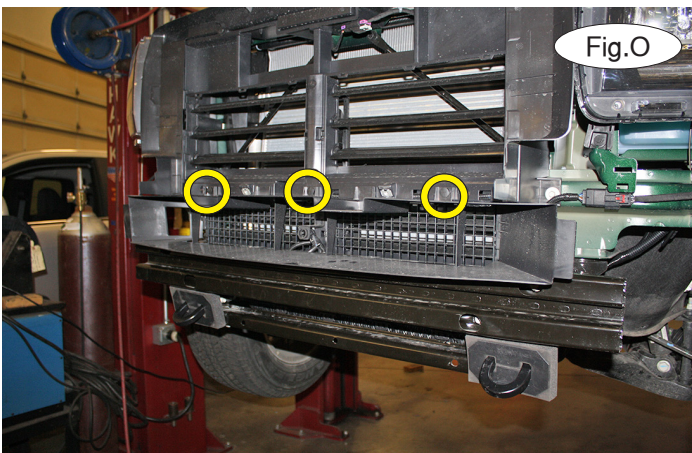

11. On each side, remove two 15mm (head) bolts attaching the bumper core to the frame (Fig.Q). Then, remove the foam covering and two 18mm (head) bolts and nuts attaching the tow hook to the frame. *Note:* the tow hooks will not be replaced. Retain the tow hooks and their hardware for replacement in case the bracket is ever removed.

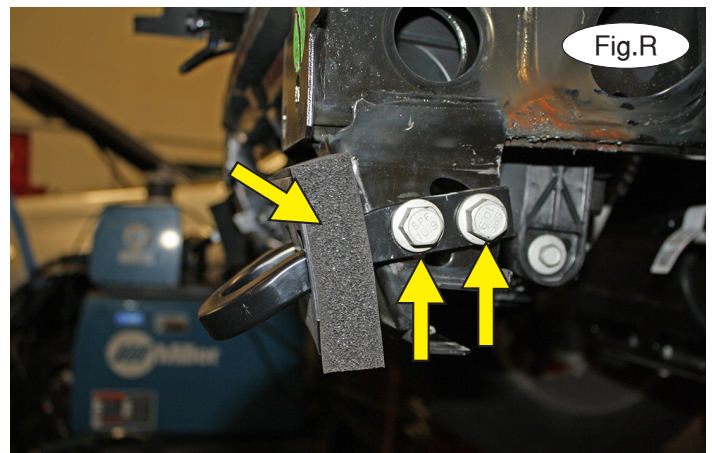
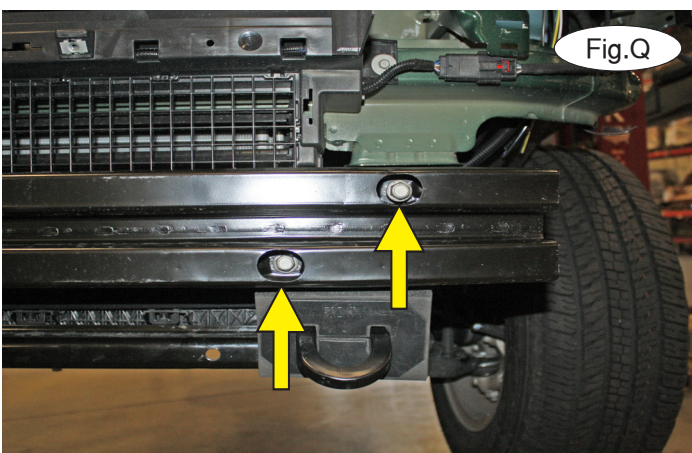



MOUNTING BRACKET KIT INSTALLATION INSTRUCTIONS

KIT# 523182-5

02/25/16

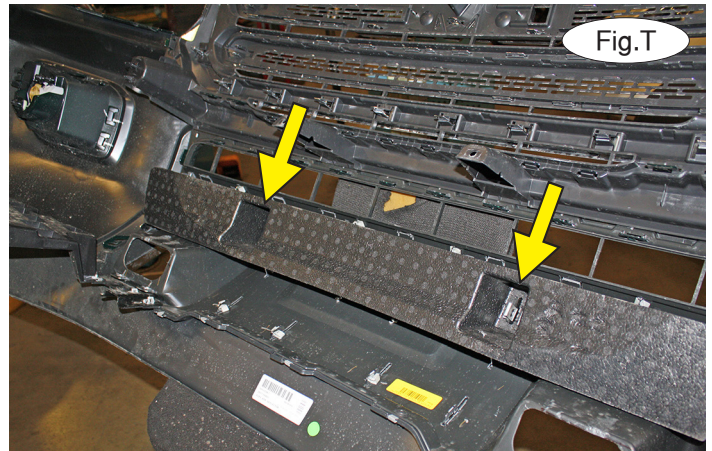
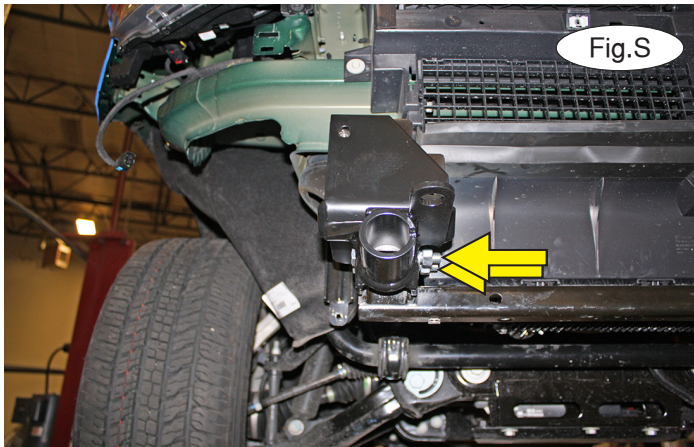

12. On each side, place the bracket around the tow hook mount and bolt it into place using two of the supplied $\frac{1}{2}$ " x $3\frac{1}{2}$ " bolts and finish with two $\frac{1}{2}$ " lock washers and nuts (Fig.S). **Note: ensure proper alignment, as the bolts will receive Loctite® Red and will be torqued at the end of these instructions.**

13. On the back of the fascia, remove two retaining clips attaching the foam shock absorption pad to the fascia (Fig.T). **Note: the foam shock absorption pad will not be replaced. Retain the pad and its hardware for replacement in case the bracket is ever removed.**



14. Replace the bumper core and its bolts over the top of the bracket. **Note: use Loctite Red on all nuts and bolts.**

15. Trim the fascia as shown (Fig.U – driver's side). **Note: models with tow hooks will only need to trim the yellow lines indicated. Models without tow hooks will need to trim the entire hole.**

Then, reinstall the fascia and air dam, reversing steps 1 through 10.

16. **Note: the following four images are for illustration purposes only, as your specific application may be slightly different.**

The spring-loaded pin on the removable arm snaps into a notch on the receiver, locking the removable arm into its final towing position. Before inserting each arm into the receiver, verify that the spring is working by ensuring that the spring-loaded pin moves easily back and forth within the barrel when pulled and that it can be pulled flush with the face of the barrel (Fig.V and Fig.W).





MOUNTING BRACKET KIT INSTALLATION INSTRUCTIONS

KIT# 523182-5

02/25/16

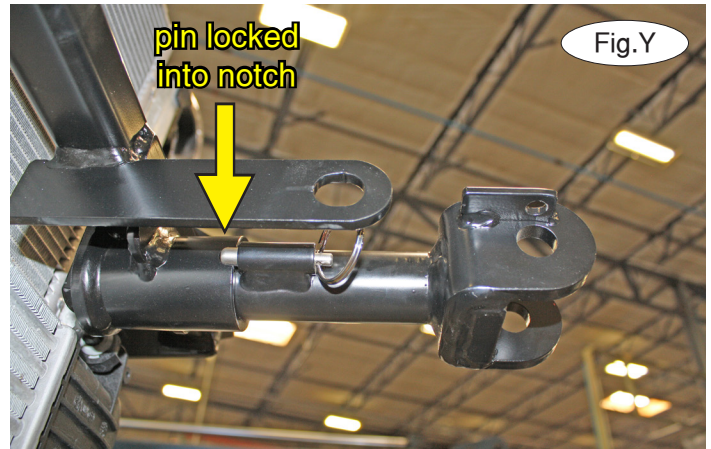
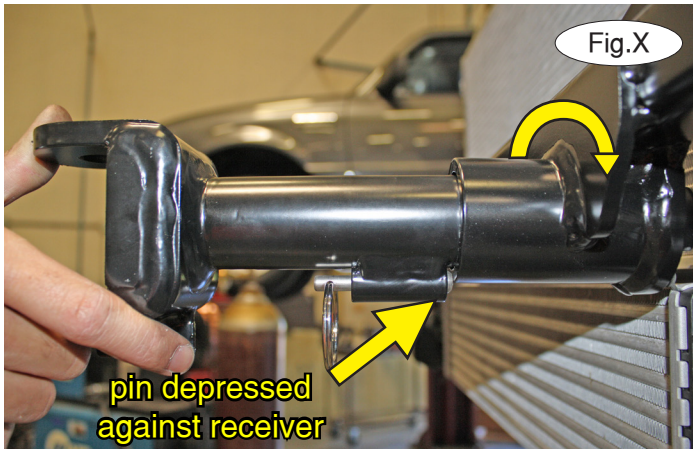

17. On each side, insert the removable front bracket arm into the front receiver 90 degrees from its final towing position, depressing the spring-loaded pin against the receiver (Fig.X). Now, twist back 90 degrees until the spring-loaded pin snaps into place in the notch on the receiver, locking the arm into place in its final towing position (Fig.Y).

Please note: it is the owner's responsibility to ensure the locking of the pins before towing. Otherwise, failure of the towing system will result.

18. Install the tow bar to the mounting bracket according to the manufacturer's instructions.

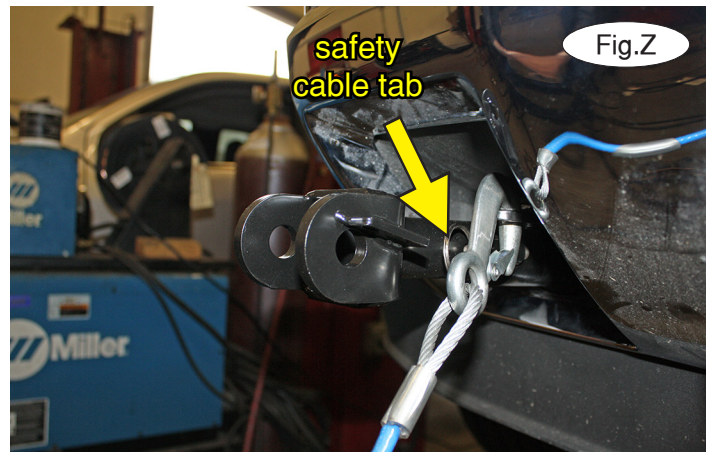

IMPORTANT!

Safety cables are required by law. When towing, connect safety cables to the safety cable tabs illustrated on the first page and in Figure Z. Make certain there is adequate slack in the cables to allow a full turning radius; otherwise, damage will result. If necessary, longer cables or cable extensions are available.

Note: if the bracket is so equipped, the holes in the alignment tabs which are welded to the arms and main receiver braces are for padlocks only. Under no circumstances should you bolt the alignment tabs together. Bolting the alignment tabs together may result in non-warranty damage to the bracket.



MOUNTING BRACKET KIT INSTALLATION INSTRUCTIONS

KIT# 523182-5

02/25/16

Three options for attaching the wiring plug to the main receiver brace

For six-wire plugs: use the two supplied 3/4" self-tapping screws to attach the electrical plug directly to the rods on the front of the main receiver brace.

For four-wire round plugs: attach to the plug mounting plate and then use the two supplied 3/4" self-tapping screws to attach the mounting plate to the rods on the front of the main receiver brace.

For four-wire flat plugs: place the plug through the mounting plug plate, and then secure it using the supplied zip tie on the front of the plug (Fig.AA). Use the two supplied 3/4" self-tapping screws to attach the mounting plate to the rods on the front of the main receiver brace.

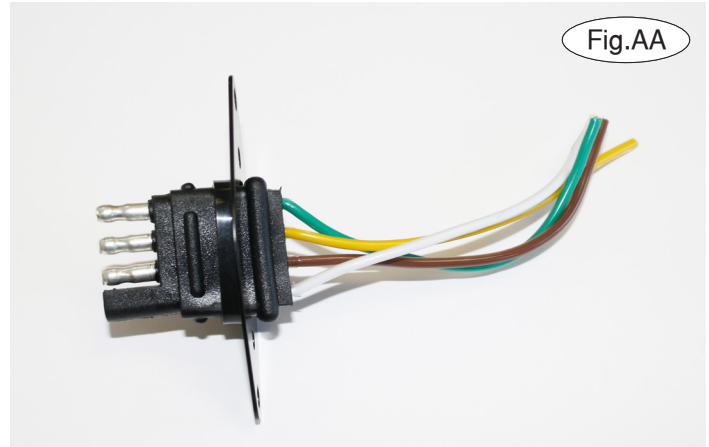

Fig.AA

BOLT TORQUE REQUIREMENTS

Note: The torque values represented below are intended as general guidelines. Torque requirements for specific applications may vary. Roadmaster does not warrant this information to be accurate for all applications and disclaims all liability for any claims or damages which may result from its use.

STANDARD BOLTS

Thread Size	Grade	Torque
5/16.....	5.....	13 ft./lb.
3/8.....	5.....	23 ft./lb.
7/16.....	5.....	37 ft./lb.
1/2.....	5.....	56 ft./lb.
5/8.....	5.....	150 ft./lb.

METRIC BOLTS

Thread Size	Grade	Plated / Unplated
8mm-1.0	8.8	20 ft./lb. 18 ft./lb.
8mm-1.25	8.8	19 ft./lb. 18 ft./lb.
10mm-1.25	8.8	38 ft./lb. 36 ft./lb.
10mm-1.5	8.8	37 ft./lb. 35 ft./lb.

METRIC BOLTS

Thread Size	Grade	Plated / Unplated
12mm-1.25	8.8	70 ft./lb. 65 ft./lb.
12mm-1.5	8.8	66 ft./lb. 61 ft./lb.
12mm-1.75	8.8	65 ft./lb. 60 ft./lb.
14mm-2.0	8.8	104 ft./lb. 97 ft./lb.

All illustrations and specifications contained herein are based on the latest information available at the time of publication approval. ROADMASTER, INC. reserves the right to make changes at any time without notice in material, specification and models or to discontinue models.