



Tow Bar Adaptor Kits

part numbers 031-5 and 034-5

Installation Instructions

All specifications are subject to change without notice.

Kit descriptions and parts

031-5

Description – adapts all ROADMASTER Sterling tow bars with serial numbers above 14,501 to Blue Ox brackets.

Parts list – (2) swivel ears; (2) round nuts; (2) base pins; (2) hairpin clips; (2) Allen head shoulder bolts; (4) plastic washers; (2) metal washers; (2) lock nuts.

034-5

Description – adapts all ROADMASTER Sterling tow bars with serial numbers above 14,501 to Demco brackets.

Parts list – (2) swivel ears; (2) round nuts; (2) safety pins with chains and linch pins; (2) Allen head shoulder bolts; (4) plastic washers; (2) lock nuts.

Required tools

1/4" Allen wrench, 9/16" wrench.

Installation instructions

WARNING

Read all instructions before installing either of the kits. Failure to understand how to properly install the kits could result in property damage, personal injury or even death.



1. Remove the 3/8" lock nut from the bottom of the Allen head shoulder bolt connecting the swivel ear to the end of one of the tow bar arms (Figure 1). Discard the original swivel ear, shoulder bolt, washers and nut.

continued on next page

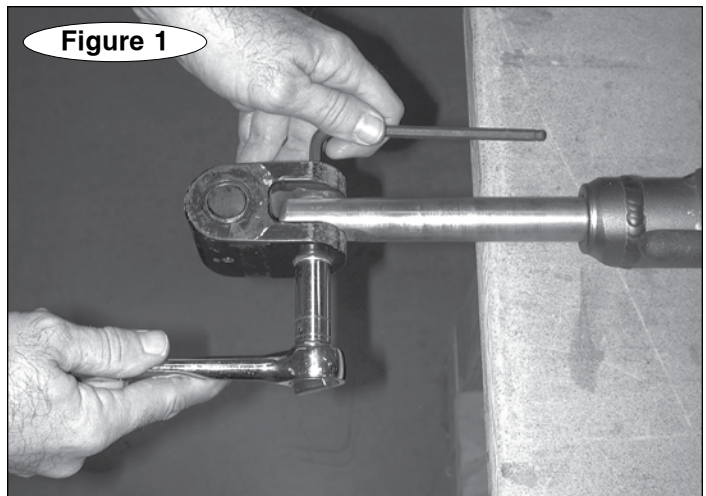
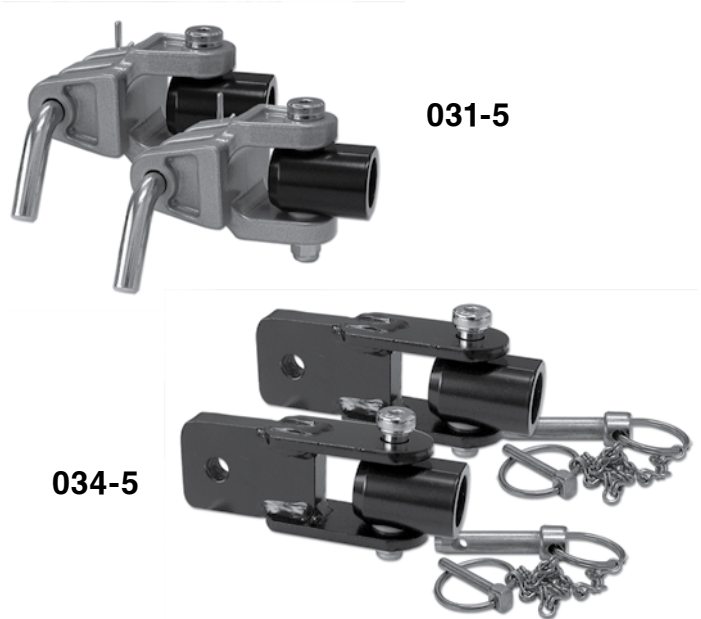

Figure 1

IMPORTANT NOTICE!

Safety Definitions

These instructions contain information that is very important to know and understand. This information is provided for **safety** and to **prevent equipment problems**. To help recognize this information, observe the following symbols:

WARNING

WARNING indicates a potentially hazardous situation which, if not avoided, could result in property damage, serious personal injury or even death.

CAUTION

CAUTION indicates a potentially hazardous situation which, if not avoided, may result in property damage, or minor or moderate personal injury.

CAUTION

CAUTION used without the safety alert symbol indicates a potentially hazardous situation which, if not avoided, may result in property damage.

NOTE

Refers to important information and is placed in italic type. It is recommended that you take special notice of these items.

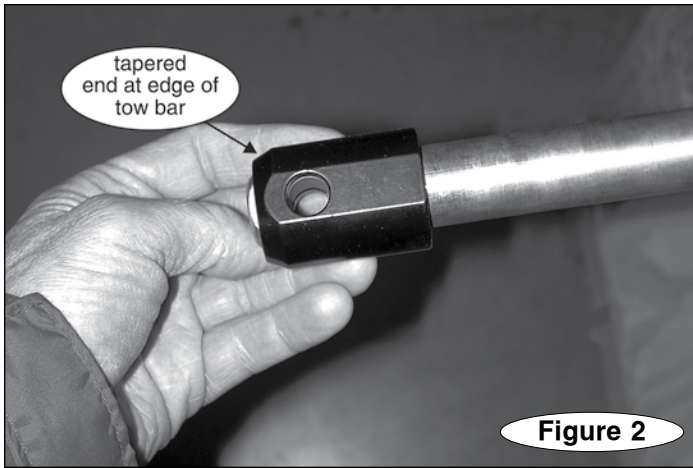

Figure 2

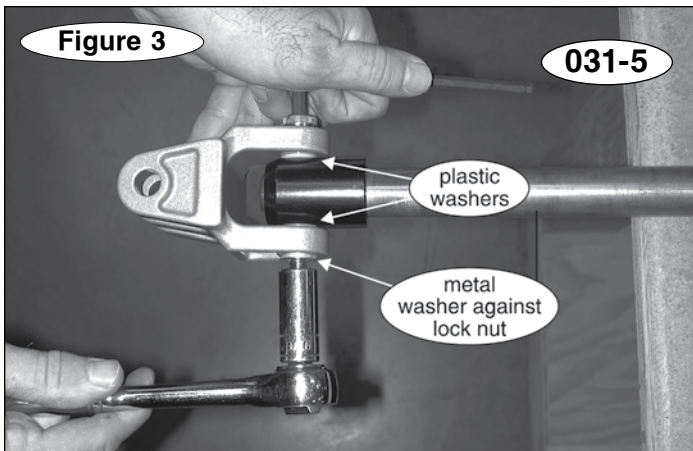

Figure 3

031-5

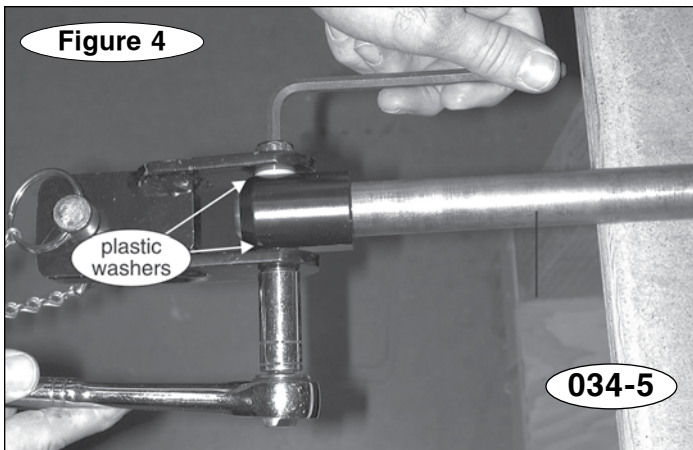

Figure 4

034-5

continued from preceding page

2. Align the hole in one of the replacement round nuts to the hole at the end of the tow bar arm.

Note: position the round nut with the tapered end at the edge of the tow bar (Figure 2).

! WARNING

Position the round nut as described above. If the round nut is positioned incorrectly, the tow bar arm will fail. The towed vehicle will separate, or be held by only one tow bar arm, which may cause property damage, personal injury or even death.

3. Attach one of the replacement swivel ears to the round nut – use one of the supplied Allen head shoulder bolts, two plastic washers (one against either side of the round nut), and one lock nut, as shown in Figures 3 and 4.

*Note: for 031-5 adaptors **ONLY** – insert one of the metal washers against the lock nut, as shown in Figure 3.*

4. Torque the lock nut to 45 ft./lbs.

5. Repeat for the other tow bar arm.



Towing and Suspension Solutions