

ROBINAIR®

Operating Manual

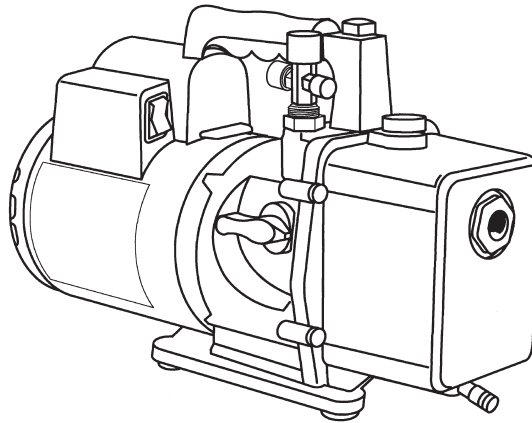

**High Performance Vacuum Pump
Models 15400 and 15600**

Robinair High Performance Vacuum Pumps

Congratulations on purchasing one of Robinair's top quality vacuum pumps. Your pump has been engineered specifically for air conditioning and refrigeration service, and is built with Robinair's proven offset rotary vane for fast, thorough evacuation.

You'll appreciate these key features...

- Iso-Valve™** Allows the pump to be shut off while still connected to the A/C-R system, which is handy for checking rate of rise. With the valve handle in the OPEN position, the pump is open to the system being evacuated. In the CLOSED position, the pump is isolated from the system.
- High Vacuum Rating** The two-stage, offset, rotary vane design provides powerful, quiet, high vacuum capability and ensures moisture removal, while the high pumping capacity reduces evacuation time.
- Lifetime Filtration** The intake filter prevents foreign matter from entering the pumping chamber, and an internal exhaust filter separates oil vapor from the exhaust flow.
- Directed Exhaust** Exhaust is expelled through the handle to direct it away from the service technician.
- Gas Ballast** A precise amount of atmospheric air is introduced into the pump, preventing condensation of moisture vapor and helping maintain the purity of the pump oil. By using the gas ballast, the pump operates more efficiently and pump life is extended.
- Sure-Grip Handle** The one-piece, molded handle makes it easy to carry the pump to and from job sites, and the handle stays cool to the touch during operation.
- Compact Design** The pump measures just 15¹/₂" long, while aluminum housing and offset rotary vanes keep the pump weight low, making it easy to carry.

For use on A/C-R systems using CFCs, HCFCs, and HFCs in conjunction with mineral oil, ester oil, alkylbenzene oil, and PAG oil as lubricants. Not for use with ammonia or lithium bromide systems. Not for use with flammable refrigerants.

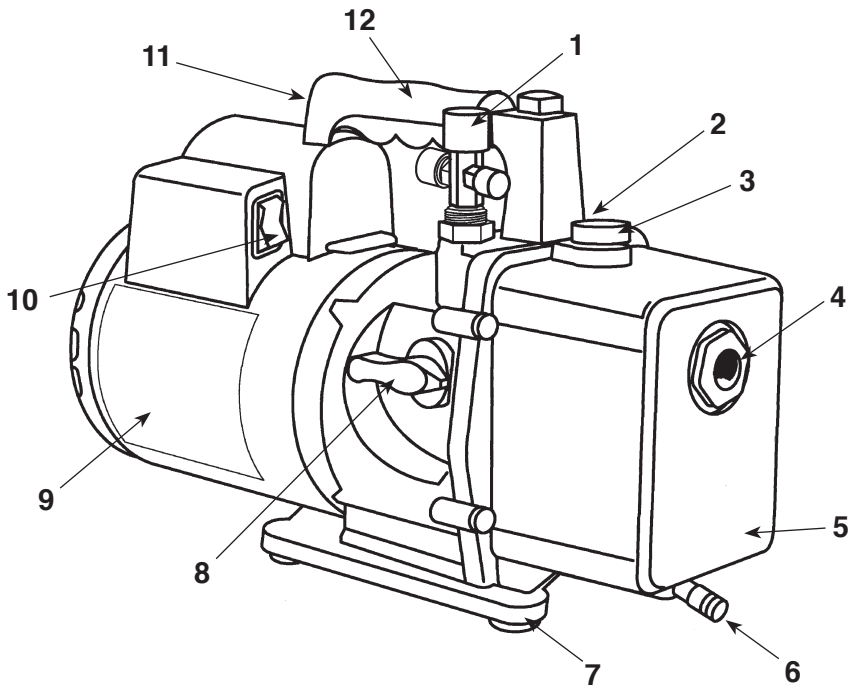

Pump Components

- | | |
|--|--|
| 1. Intake Fitting | 7. Molded Polycarbonate Base |
| 2. Gas Ballast Valve
(located beside handle base) | 8. Iso-Valve™
(isolates the pump from the system) |
| 3. Oil Fill Port | 9. High-Torque Motor |
| 4. Sight Glass | 10. Power Switch |
| 5. Die-Cast Aluminum Housing | 11. Through-The-Handle Exhaust |
| 6. Oil Drain | 12. Sure-Grip Handle |

⚠ WARNING! ⚠



Wear safety goggles when working with refrigerants. Contact with refrigerants may cause eye injury.



Incorrect use or electrical connections may cause electrical shock. Read and follow instructions carefully, and take precautions to avoid electrical shock hazards. All associated devices must be correctly grounded before energizing circuits.



Normal operating temperatures will cause certain external portions of the pump to be hot to the touch. Do not touch the pump housing or motor during operation.

Before using your vacuum pump...

Note on Motor Voltage Connections:

In all cases, motors are designed for operating voltages, plus or minus 10% of the normal rating (see SPECIFICATIONS). Single voltage motors are supplied fully connected and ready to operate.

1. Verify the voltage and frequency at the outlet match the specifications on the pump motor decal. Place the ON / OFF switch in the OFF position before you plug the pump into an outlet. Verify the gas ballast valve is closed. Remove and discard the exhaust plug from the end of the pump handle.
2. The pump is shipped without oil in the reservoir. Before starting the pump, fill it with oil. Remove the OIL FILL cap (plastic plug directly in front of the handle), and add oil until oil just shows in the bottom of the sight glass. The approximate oil capacity of the pump is 15 ounces.
3. Replace the OIL FILL cap, and remove the cap from one of the inlet ports. OPEN the Iso-Valve™ . Turn ON the motor switch. When the pump runs smoothly, CLOSE the Iso-Valve™ , and replace the cap on the inlet port. This may take from two to 30 seconds depending on ambient temperature. After the pump runs for approximately one minute, check the sight glass for the correct oil level — the oil should be even with the sight glass OIL LEVEL line. Add oil if necessary.

Note: When the pump is running, the oil level should be even with the line on the sight glass. Underfilling will result in poor vacuum performance; overfilling can result in oil blowing from the exhaust.

Your pump is now ready to evacuate air conditioning and refrigeration systems. Follow normal service procedures and the A/C-R manufacturer's instructions for connections to the system.

CAUTION Before connecting your vacuum pump to an A/C-R system, remove refrigerant from the system in an accepted manner using an approved recovery unit. Damage to the pump may occur if evacuation is started while the system is under high pressure.

To use the gas ballast feature...

Moisture from the A/C-R system that is carried into the pump as a vapor tends to condense into a liquid and combine with the vacuum pump oil. When moisture contaminates the pump oil, it reduces the pump's ability to reach its ultimate deep vacuum level.

The gas ballast valve purges a small amount of atmospheric air through the exhaust chamber. This extra volume of air mixes with the vapor from the refrigerant system to prevent condensation and to help exhaust moisture in the form of vapor from the pump.

The gas ballast valve is located beside the handle, opposite the inlet fitting. To use the gas ballast, start the pump and open the gas ballast valve until the system has reached 1000–3000 microns. Close the valve to allow the pump to pull down to its ultimate vacuum level.

The gas ballast valve may be opened or closed at any time during pump operation. It is fully open at two turns counterclockwise.

Note: Robinair recommends the use of a thermistor vacuum gauge to most accurately measure vacuum levels.

To shut down the pump after use...

To prolong pump life and promote easy starting, follow these procedures for shutdown:

1. Close the manifold valve between the pump and the system.
2. Turn the Iso-Valve™ to the CLOSED position.
3. Remove the hose from the pump inlet.
4. Turn the pump power switch to OFF. Return the Iso-Valve™ to the OPEN position for a few seconds to relieve any vacuum inside the pump.
5. Cap the inlet port to prevent any contamination or loose particles from entering the port.

To maintain the high vacuum pump...

Vacuum Pump Oil

For maximum performance, Robinair recommends changing vacuum pump oil after each use.

The condition and type of oil used in any high vacuum pump are extremely important in determining the ultimate attainable vacuum. Robinair recommends the use of our Premium High Vacuum Pump Oil. This oil has been specifically blended to maintain maximum viscosity at normal running temperatures and to improve cold weather starts.

Robinair Premium High Vacuum Pump Oil is available in handy quart containers or in convenient gallon containers. Order by part number:

13203 — Quart (shipped 12 quarts per case)

13204 — Gallon (shipped 4 gallons per case)

Oil Change Procedure

1. Allow the pump to run until it is warmed up.
2. Remove the OIL DRAIN cap. Drain contaminated oil into a suitable container and dispose of it according to the regulations in your jurisdiction. Oil can be forced from the pump by opening the inlet and partially blocking the exhaust with a cloth while the pump is running. Do not operate the pump for more than 20 seconds using this method.
3. When the flow of oil has stopped, tilt the pump forward to drain residual oil.
4. Replace the OIL DRAIN cap. Remove the OIL FILL cap, and fill the reservoir with new vacuum pump oil until the oil just shows at the bottom of the sight glass. The approximate oil capacity of the pump is 15 ounces.
5. Verify the inlet ports are capped, and turn ON the pump. Allow it to run for one minute, and check the oil level. If the oil is below the sight glass OIL LEVEL line, add oil slowly (with the pump running) until the oil reaches the OIL LEVEL line. Replace the OIL FILL cap, making sure the inlet is capped and the drain cap is tight.
6. a) If the oil is badly contaminated with the sludge that forms when water is allowed to collect in the oil, you may need to remove the oil reservoir cover and wipe it out.

- b) Another method of dealing with heavily contaminated oil is to force the oil from the pump reservoir. To do this, allow the pump to run until it is warmed up. While the pump is still running, remove the oil drain cap. Slightly restrict the exhaust. This will back-pressure the oil reservoir and force the oil from it, carrying more contaminants. When the oil ceases to flow, turn off the pump.

Repeat this procedure as required until the contamination is removed. Replace the OIL DRAIN cap, and refill the reservoir to the correct level with fresh pump oil (see Step 4).

Cleaning the Pump

Clean the pump using only soap and water. Do not use commercial cleaners containing degreasing agents that can damage polycarbonates. The pump handle and base are made of Lexan[®], one of the toughest polycarbonate plastics available, but it is sensitive to degreasing agents.

**Lexan is a registered trademark of General Electric.*

Troubleshooting Guide

This Robinair pump has been designed for dependable use and long life. If something should go wrong, however, the following guide will help you get the pump back into service as quickly as possible.

If disassembly of the pump is required, please check your warranty. The warranty may be voided by misuse or customer tampering that results in the pump being inoperable.

Failure To Start

Check line voltage. Robinair pumps are designed to start at $\pm 10\%$ line voltage (loaded) at 32° F. At extremes, however, switching between the start and run windings may occur.

Oil Leakage

1. Verify the oil is not a residual accumulation from spillage, etc.
2. If leakage exists, the module cover gasket or the shaft seal may need replacing. Follow the instructions supplied with Seal Replacement Kit No. 15367. If leakage exists in the area of the oil drain plug, you may need to reseal the plug using a commercial pipe thread sealer.

Failure To Pull A Good Vacuum

1. Verify the Iso-Valve[™] on the pump is in the OPEN position.
2. Verify the vacuum gauge and all connections are in good condition and leak-free. Confirm leakage by monitoring the vacuum with a thermistor gauge while applying vacuum pump oil at connections or suspected leak points. Vacuum will improve briefly while the oil is sealing the leak.

3. Verify the pump oil is clean. A badly contaminated pump may require several oil flushes. See *OIL CHANGE PROCEDURE*.

Note: Use only high vacuum pump oil such as Robinair's Premium High Vacuum Pump Oil. Other oils will prevent pull-down to a deep vacuum.

4. Verify the gas ballast knob is tightly closed.
5. Verify the oil is at the correct level. For maximum pump operation, the oil must be even with the OIL LEVEL line on the sight glass when the pump is running. See *OIL CHANGE PROCEDURE*. Do not overfill — operating temperatures will cause the oil to expand so it will appear at a higher level than when the pump is not running. To check the oil level, start the pump with the inlet capped. Check the oil level in the sight glass. Add oil if necessary.

When You Need Help

If these procedures do not correct the problem, contact your nearest Robinair distributor. The distributor may recommend an additional replacement part (this manual contains a replacement parts list) or suggest you send your pump to the nearest authorized service center.

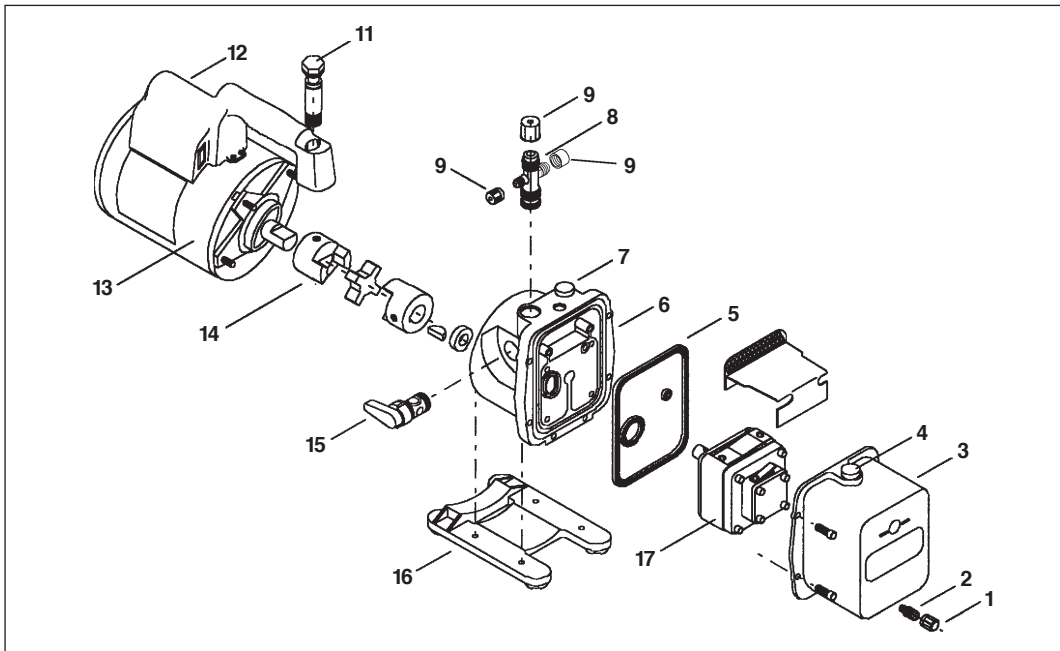

Replacement Parts

Part	Figure	15400	15600
Oil Drain Cap (qty. 6)	1	40572	40572
Oil Drain Kit (includes oil drain cap)	2	48116	48116
Module Cover Kit (includes items 2, 4, 5)	3	15337	15337
Oil Fill Cap (includes gas ballast valve)	4	15371	15371
Intake Fitting (includes intake caps)	8	15364	555124
Intake Caps (1/4", 3/8", and 1/2" flare; 1 ea.)	9	555133	555133
Vent Bolt (includes o-rings)	11	15338	15338
Handle, Power Cord, Switch Assembly	12	15366	15366
Motor	13	15365	15370
Coupling	14	48103	48103
Iso-Valve™ Assembly	15	15368	15368
Base and Foot Assembly	16	15369	15369
Replacement Module (includes Nos. 1 through 7)	17	15547	15548
Seal Replacement Kit (not shown)	--	15367	15367

Pump Specifications

Model	15400	15600
Free Air Displacement	4 CFM	6 CFM
Stages	2	2
Motor Speed	1725 RPM	1725 RPM
Voltage $\pm 10\%$	115V 60 Hz	115V 60 Hz
Factory Micron Rating	15 microns	15 microns
Approximate Oil Capacity	15 oz.	15 oz.
Weight	27 lbs.	27 lbs.
Width	5 ⁵ / ₈ in.	5 ⁵ / ₈ in.
Height	9 ³ / ₄ in.	9 ³ / ₄ in.
Length	15 ¹ / ₂ in.	15 ¹ / ₂ in.
Intake	1/2" and 1/4" SAE MFL	1/4", 3/8", and 1/2" SAE MFL
Min. Starting Temperature (at 90% Voltage)	32° F	32° F
Motor Size	1/2 hp; capacitor start	1/2 hp; capacitor start
Operating Temp.	155° F	155° F

- Note:*
1. All motors are internally protected (automatic reset).
 2. Operating temperatures are typical for normal operating conditions.

Due to ongoing product improvements, we reserve the right to change design, specifications, and materials without notice.

ROBINAIR