

Original Instructions

Model: 34888HD



Recover, Recycle, Recharge Machine  
for Heavy Duty R-134a A/C Systems

---

*Description: Recover, recycle, and recharge machine for use with R-134a equipped air conditioning systems.*

## **PRODUCT INFORMATION**

Record the serial number and year of manufacture of this unit for future reference. Refer to the product identification label on the unit for information.

**DISCLAIMER:** Information, illustrations, and specifications contained in this manual are based on the latest information available at the time of publication. The right is reserved to make changes at any time without obligation to notify any person or organization of such revisions or changes. Further, ROBINAIR shall not be liable for errors contained herein or for incidental or consequential damages (including lost profits) in connection with the furnishing, performance, or use of this material. If necessary, obtain additional health and safety information from the appropriate government agencies, and the system, refrigerant, and lubricant manufacturers.

---

# Table of Contents

<b>Safety Precautions</b> .....	<b>2</b>	<b>Maintenance</b> .....	<b>26</b>
Safety Signal Words Used in this Manual .....	2	Maintenance Schedule .....	26
Safety Decals Used on the Machine .....	2	Load Language .....	27
Protective Devices .....	4	Edit Print Header .....	27
Refrigerant Tank Test .....	4	Replace Printer Paper .....	27
Requirement Regarding Lubricant .....	4	Filter Maintenance .....	28
		Check Remaining Filter Capacity .....	28
<b>Introduction</b> .....	<b>5</b>	Replace the Filter .....	29
Technical Specifications .....	5	Calibration Check .....	30
Features .....	6	Change Vacuum Pump Oil .....	31
Control Panel Functions .....	8	Empty Vacuum Pump Exhaust Bottle .....	32
Icon Legend .....	9	Tank Removal .....	32
Setup Menu Functions .....	10	Leak Check .....	33
Unpack the Accessory Kit .....	12		
Power Up the Machine .....	12	<b>A/C Service Functions</b> .....	<b>34</b>
		Replacement Parts .....	34
<b>Initial Setup</b> .....	<b>13</b>		
Tank Installation .....	13	<b>Troubleshooting</b> .....	<b>35</b>
Select Language .....	14		
Approve Licensing Agreement .....	14	<b>Storage and Transportation of Equipment</b> ...	<b>38</b>
Select Units .....	14	Storage .....	38
Set Date and Time .....	14	Transportation of Equipment .....	38
Edit Print Header .....	15		
Service Vacuum .....	15	<b>Disposal of Equipment</b> .....	<b>39</b>
Tank Fill .....	16	Disposal of Recycled Materials .....	39
Unit Activation .....	17	Disposal of the Machine .....	39
		Disposal of Batteries .....	39
<b>Operating Instructions</b> .....	<b>18</b>		
Enter Service Data .....	18	<b>Software License Notices</b> .....	<b>40</b>
Recover Refrigerant from A/C System .....	19	<b>IAR Software License Agreement</b> .....	<b>41</b>
Evacuate the A/C System .....	20	<b>Freescale MQX RTOS 4.0.2</b> .....	<b>51</b>
Flushing the Hoses .....	21		
Recharge the A/C System .....	22		
Automatic Function .....	23		
System Flush .....	24		
N2 and N2H2 Leak Test .....	25		

# Safety Precautions

---

## Explanation of Safety Signal Words Used in this Manual

The safety signal word designates the degree, or level, of hazard seriousness.

 **DANGER:** Indicates an imminently hazardous situation which, if not avoided, will result in death or serious injury.

 **WARNING:** Indicates a potentially hazardous situation which, if not avoided, could result in death or serious injury.

 **CAUTION:** Indicates a potentially hazardous situation which, if not avoided, could result in minor or moderate injury.

**CAUTION:** Used without the safety alert symbol indicates a potentially hazardous situation which, if not avoided, could result in property damage.

These safety messages cover situations Robinair is aware of. Robinair cannot know, evaluate, or advise as to all possible hazards. The user must verify that conditions and procedures do not jeopardize personal safety.

## Explanation of Safety Decals Used on the Machine

	Carefully read the instructions.
	Do not use in open air in case of rain or high humidity.
	Wear gloves.
	Wear protection goggles.
	Alternating voltage.
	Grounding protection.
	Electrical shock hazard.

# Safety Precautions



## **WARNING: To prevent personal injury,**



**ALLOW ONLY QUALIFIED PERSONNEL TO OPERATE THE MACHINE.** Before operating the machine, read and follow the instructions and warnings in this manual. The operator must be familiar with air conditioning and refrigeration systems, refrigerants, and the dangers of pressurized components. If the operator cannot read this manual, operating instructions and safety precautions must be read and discussed in the operator's native language.



**USE THE MACHINE AS OUTLINED IN THIS MANUAL.** Using the machine in a manner for which it was not designed will compromise the machine and nullify the protections provided.



**PRESSURIZED TANK CONTAINS LIQUID REFRIGERANT.** Do not overfill the external storage vessel (tank). Overfilling can cause explosion resulting in personal injury or death. Do not recover refrigerants into nonrefillable containers; use only type-approved refillable containers that have pressure relief valves.



**HOSES CAN CONTAIN LIQUID REFRIGERANT UNDER PRESSURE.** Contact with refrigerant can cause personal injury, including blindness and frozen skin. Wear protective equipment, including goggles and gloves. Disconnect hoses using extreme caution. Ensure the phase is complete before disconnecting the machine to prevent the release of refrigeration to the atmosphere.



**AVOID BREATHING A/C REFRIGERANT AND LUBRICANT VAPOR OR MIST.** Exposure can irritate eyes, nose, and throat. To remove refrigerant from the A/C system, use only equipment certified for the type of refrigerant being removed. Use the unit in locations with mechanical ventilation that provides at least four air changes per hour. If accidental system discharge occurs, ventilate the work area before resuming service.

**DO NOT DISPERSE REFRIGERANT INTO THE ENVIRONMENT.** Prevent the possible presence of refrigerant in the working environment.



**TO REDUCE THE RISK OF FIRE,** do not use the machine in the vicinity of spilled or open containers of gasoline or other flammable substances.

**TO REDUCE THE RISK OF FIRE,** do not use an extension cord. An extension cord can overheat and cause fire. If an extension cord must be used, use the shortest possible cord with a minimum size of 14 AWG.

**TO REDUCE THE RISK OF FIRE,** do not use the machine in the vicinity of flames and hot surfaces. Refrigerant can decompose at high temperatures and free toxic substances to the environment that can be noxious to the user.

**TO REDUCE THE RISK OF FIRE,** do not use the machine in environments containing explosive gases or vapors.

**TO REDUCE THE RISK OF FIRE,** do not use this machine in ATEX classified zones or areas. Protect the machine from conditions that can cause electrical failure or other hazards relating to ambient interaction.



**CAUTION—DO NOT PRESSURE TEST OR LEAK TEST EQUIPMENT AND/OR AIR CONDITIONING SYSTEMS WITH COMPRESSED AIR.** Mixtures of air and R-134a refrigerant can be combustible at elevated pressures. These mixtures are potentially dangerous and can result in fire or explosion causing personal injury and/or property damage.



**HIGH VOLTAGE ELECTRICITY INSIDE THE MACHINE HAS A RISK OF ELECTRICAL SHOCK.** Exposure can cause personal injury. Disconnect power before servicing the machine.

**NEVER LEAVE THE MACHINE LIVE IF AN IMMEDIATE USE IS NOT SCHEDULED.** Disconnect the electrical supply before a long period of inactivity or before internal maintenance is performed.

**DO NOT MODIFY THE PRESSURE RELIEF VALVE OR CHANGE THE CONTROL SYSTEM SETTINGS.** Using the machine in a manner for which it was not designed will compromise the machine and nullify the protections provided.

**Additional health and safety information can be obtained  
from refrigerant and lubricant manufacturers.**

# Safety Precautions

---

## CAUTION : To prevent equipment damage,

---



**TO PREVENT CROSS-CONTAMINATION, USE THIS MACHINE WITH R-134A REFRIGERANT ONLY.** The machine is equipped with special connectors to recover, recycle, and recharge only R-134a refrigerant. Do not attempt to adapt the machine for another refrigerant. Do not mix refrigerant types through a system or in the same container; mixing of refrigerants will cause severe damage to the machine and the air conditioning system.

**DO NOT USE THIS MACHINE IN DIRECT SUNLIGHT.** Position the machine far from heat sources, such as direct sunlight, which can cause excessive temperatures. The use of this machine under normal environmental conditions (10°C to 50°C) keeps pressures under reasonable limits.



**DO NOT USE THIS MACHINE OUTDOORS DURING RAIN OR HIGH HUMIDITY.** Protect the machine from conditions that can cause electrical failure or other hazards relating to ambient interaction.

**DO NOT USE THIS MACHINE IN AREAS WHERE THERE IS A RISK OF EXPLOSION.**

**SET UP THE MACHINE ON AN EVEN SURFACE AND UNDER SUFFICIENT LIGHTING. LOCK THE FRONT WHEELS, AND DO NOT SUBJECT THE MACHINE TO VIBRATION.**

**TO AVOID CHEMICAL INCOMPATIBILITIES WITH THE INTERNAL COMPONENTS OF THE MACHINE, USE ONLY OILS APPROVED BY THE SYSTEM MANUFACTURER.** Problems resulting from the use of non-approved oils will void the warranty.

**Additional health and safety information can be obtained from refrigerant and lubricant manufacturers.**

## Protective Devices

The machine is equipped with the following protective devices:

- Over pressure valves.
- A maximum pressure switch stops the compressor when excessive pressure is sensed.



**WARNING: Tampering with these protective devices could result in serious injury.**

---

## Refrigerant Tank Test

Official records and recurring tests necessary for pressurized instruments are governed by laws and/or national regulations dependent upon the country where the refrigerant tank is used. The system manager is responsible for compliance with laws, regulations, and technical rules. During normal service, refrigerant tanks do not need maintenance. Refer to the Maintenance section of this manual for more information.

## Requirement Regarding Lubricant

Only new lubricant, as specified by the system manufacturer, shall be installed in the MAC system. Lubricant removed from the system and/or the equipment shall be disposed of in accordance with applicable federal, state, and local procedures and regulations.

This machine is used on high-capacity R-134a mobile A/C systems and is designed to be compatible with existing service equipment and standard service procedures. This machine is a single-pass system (i.e. refrigerant flows through a filter once) that meets specifications for recycled refrigerant. Follow recommended service procedures for the containment of R-134a.

*Note: Refrigerant systems require special oils. Refer to the A/C system manufacturer's service manual for oil specifications.*



---

## Technical Specifications

---

<b>Dimensions</b> .....	117 cm x 66 cm x 85 cm
<b>Display</b> .....	5 × 9 cm (4.3-in. diag) graphical LCD
<b>Filter</b> .....	136 kg (300 lb)
<b>Humidity</b> .....	32.2°C (90°F), 80% RH non-condensing
<b>Manometer</b> .....	Ø 100 mm (3.9 in.)
<b>Maximum Pressure</b> .....	17.9 bar (260 psi)
<b>Noise</b> .....	<72 dB(A)
<b>Nominal Voltage</b> .....	115V, 60 Hz
<b>Oil Bottle Capacity</b> .....	355 ml (12 oz)
<b>Operating Temperature</b> . . .	10°C to 50°C (50°F to 122°F)
<b>Power Consumption</b> .....	1380 W
<b>Vacuum Pump Free-Air Displacement</b> .....	5.0 CFM (142 L/m) @ 60 Hz
<b>Service Hoses</b> .....	5.5 m (18 ft) / SAE J2196
<b>Tank Capacity</b> .....	20 kg (44 lb)
<b>Weight</b> .....	100 kg (220 lb)



# Introduction

## Features

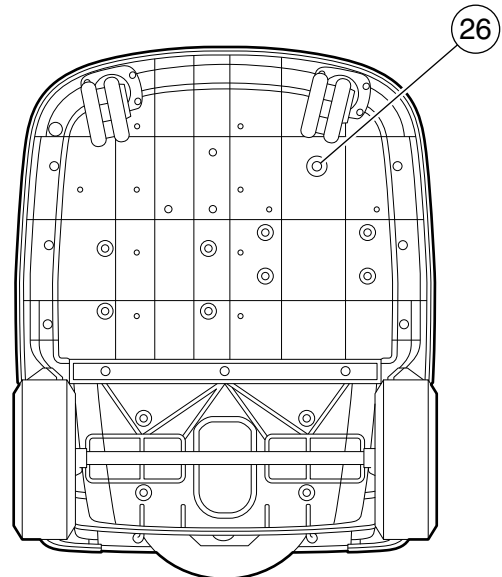
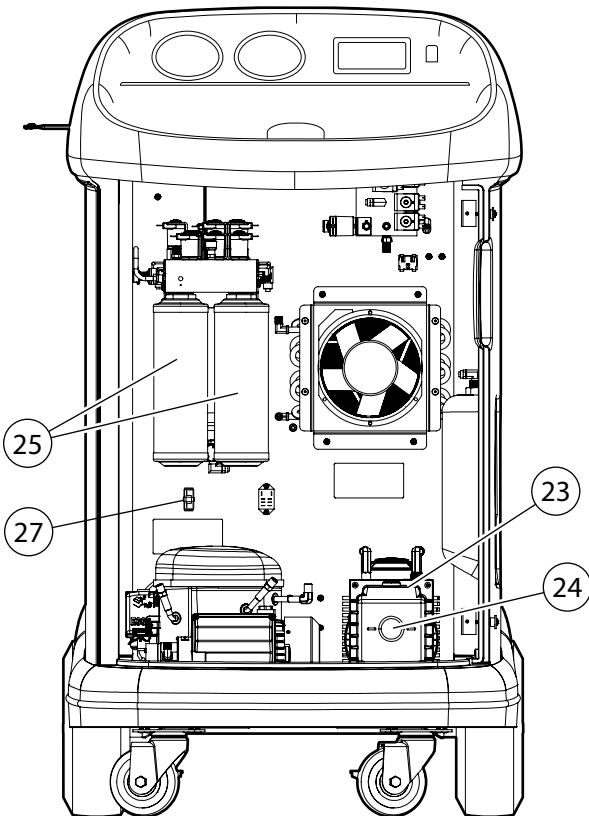
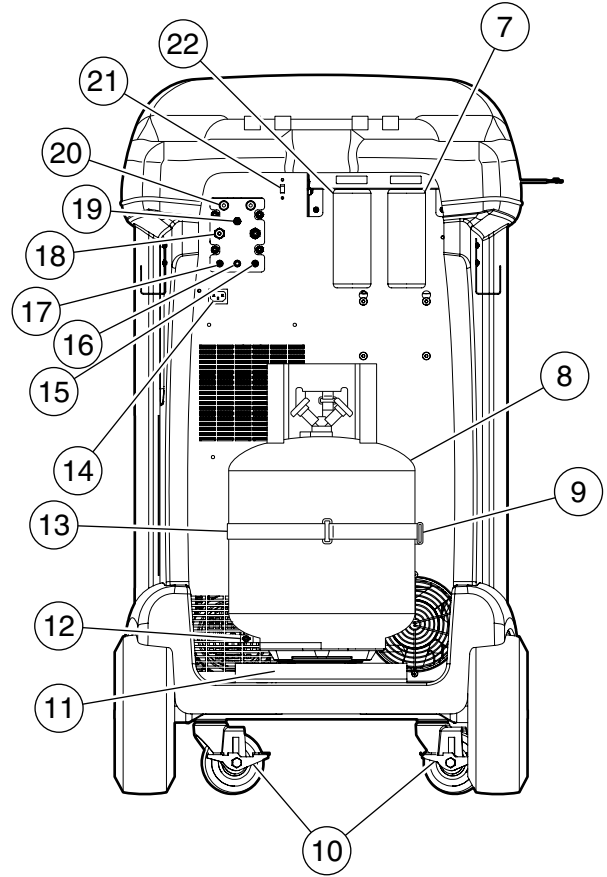
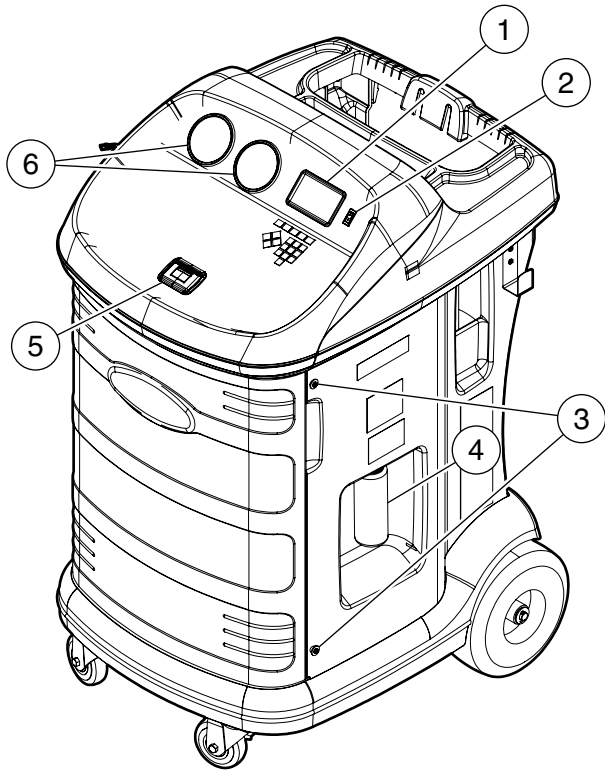



Item No.	Description
1	Graphic Display and Keypad
2	Power Switch
3	Door Screw
4	Vacuum Exhaust Bottle
5	Printer
6	Low-side (blue) and High-side (red) Manifold Gauges
7	Oil Inject Bottle
8	Tank
9	Tank Temperature Probe
10	Wheel Lock
11	Scale
12	Scale Thumb Screw
13	Tank Temperature Probe Strap
14	Power Cord Receptacle
15	Bulkhead Liquid Port
16	Bulkhead Vapor Port
17	Bulkhead Air Purge Port
18	Service Hose Storage Ports
19	Nitrogen Inject Port
20	Service Hoses
21	USB Connection
22	Oil Drain Bottle
23	Vacuum Pump Fill Cap and Port
24	Vacuum Pump Oil Sight Glass
25	Filters
26	Vacuum Pump Drain Fitting
27	Circuit Breaker

# Introduction

---

## Control Panel Functions

**ARROW UP** highlights the previous item.

**ARROW DOWN** highlights the following item.

**ARROW RIGHT** scrolls to next screen.

**ARROW LEFT** scrolls to previous screen.

**SELECTIONARROWS** make a selection or answer a query.

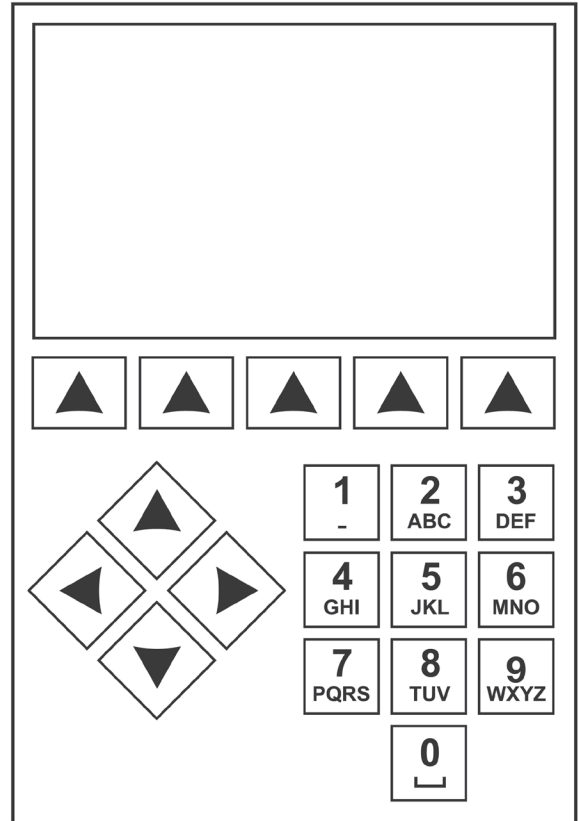

*Control Panel Keypad*

## Icon Legend



### **AUTOMATIC ICON**

Pressing the key under this icon will enter the automatic refrigerant recovery, vacuum, and charge process.



### **RECOVER ICON**

Pressing the key under this icon will enter the refrigerant recovery process.



### **VACUUM ICON**

Pressing the key under this icon will enter the system vacuum process.



### **CHARGE ICON**

Pressing the key under this icon will enter the refrigerant charge process.



### **N2/N2H2 LEAK TEST ICON**

Pressing the key under this icon will enter the N2 or N2H2 leak test process.



### **VCI ICON**

Pressing the key under this icon will connect to the optional wireless OBDII interface.



### **NEXT/FORWARD ICON**

Pressing the key under this icon will proceed to additional menu selection options, or proceed to an additional step in a function or process.



### **BACK ICON**

Pressing the key under this icon will return to previously seen menu selection options, or return to the previous screen within a function or process.



### **HELP ICON**

Pressing the key under this icon will provide help and information corresponding to the current screen and/or function being viewed or performed.



### **DATABASE ICON**

Pressing the key under this icon will enter the database retrieval process.



### **SETUP MENU ICON**

Pressing the key under this icon will enter the Setup Menu.



### **YES/ACCEPT ICON**

Pressing the key under this icon will accept any choices made on the current screen and proceed to the next step of the function.



### **NO/CLOSE ICON**

Pressing the key under this icon will reject any choices made on the current screen and return to the previous step of the function or the Main Menu.



### **RETRY ICON**

Pressing the key under this icon will retry the current process or function.



### **CHARGE PATH SELECTION ICON**

Pressing the key under this icon will toggle the desired path of refrigerant charge between high side, low side, and both side.



### **ON/OFF ICON**

Pressing the key under this icon will toggle the highlighted function on or off as desired.



### **BACKSPACE ICON**

Pressing the key under this icon will delete a text character to the left of the current selection.



### **PAUSE ICON**

Pressing the key under this icon will pause the current process.



### **RESUME ICON**

Pressing the key under this icon will resume a process that has been paused.



### **PRINT ICON**

Pressing the key under this icon will print a summary corresponding to the current completed process.



### **DELETE ICON**

Pressing the key under this icon will delete a selected entry from the memory of the machine.



### **CHANGE UNITS ICONS**



Pressing the key under one of these icons will toggle the unit of measurement for the current entry field.

# Introduction

---

## Setup Menu Functions

Access the following functions by pressing the Menu key and selecting Setup.

### Adjust Zero Offset

Allows user to set the zero offset of the oil inject and drain load cells.

### Air Purge Information

Displays current tank pressure and temperature along with calculated nominal pressure.

### Calibration Check

Use to verify internal scale calibration. Refer to Calibration Check in the Maintenance section of this user manual.

### Date and Time

Program the machine for current date and time.

### Display Title Information

Temporarily display the unit sensor information. Sensor information will default to not being displayed if the machine is turned off.

### Edit Print Header

Programs information that will appear on the printout each time a print function is used.

### Filter Maintenance

The filter removes acid, particulates, and moisture from the refrigerant. To meet requirements, it is mandatory to replace the filter after 136 kg (300 lb) of refrigerant has been filtered.

This menu item displays the filter capacity remaining until the machine locks down and no longer functions. Refer to Filter Maintenance in the Maintenance section.

### Flush Hoses

Flushes residual oil from the machine's service hoses to prepare for service of next system.

### Hose Equalize

Use this Setup Menu item to recover refrigerant from the service hoses back into the A/C system. This item is useful after performing diagnostics which do not require the need to recover the A/C system into the RRR machine. The user will be prompted to connect the low side service hose to the appropriate port and to start the A/C system on max.

### Leak Check

Use this function to test the machine for leaks. Components containing refrigerant are pressurized and monitored for pressure decay, which could indicate a leak.

### Production Menu

For Robinair production use only.

### Pump Maintenance

Displays the amount of time remaining until the next vacuum pump oil change is needed. For maximum vacuum pump performance, change vacuum pump oil every time the filter is replaced. Refer to the Change Vacuum Pump Oil in the Maintenance section.

### Refrigerant Management

Displays the amount of refrigerant recovered, charged, and replenished (for the life of the machine), and filtered since the last filter change.

### Replace Service Hoses

This function ensures that there is no residual pressure in the service hoses before replacement. Initiate this process before attempting to replace the service hoses and follow the on-screen prompts.

### Select Language

Select a language for screen prompts. English is the default language.

### Service Menu

For Robinair service center use only.

### Select Units

Program the machine to display units of measure in kilograms or pounds. The default display is kilograms.

### Set Buzzer

Turn audible alerts on and off.

### Set Default Vacuum Time

Allows the user to change the default vacuum time. The initial default time is set to 10 minutes.

### Set Up Wireless Dongle

Use this function to configure the optional Wi-Fi/Bluetooth radio.

### System Flush

Provides a method of removing oil by forcing liquid refrigerant through an A/C system or components of an A/C system. After flushing, the refrigerant is recovered by the machine and filtered by the recycling circuit.

### System Information

Displays the revision level of the software in the machine.

**Tank Fill**

Use this Setup Menu item to transfer refrigerant from a source tank to the tank. The tank fill value may be adjusted up or down to suit the user's needs. Refer to Tank Fill in the Maintenance section.

**Unit Activation**

Failure to register and activate the machine within 30 days of initial startup will cause the machine to lock out and no longer function. Select this Setup Menu item and follow the prompts before the trial period expires.

**View Service Data**

Displays A/C system information that was entered into the Enter Service Data screen. Systems are displayed by date of service and VIN or ID number. The database stores 25 entries.

# Introduction

---

## Unpack the Accessory Kit

Unpack the accessory kit from the box, and remove the plastic packaging.

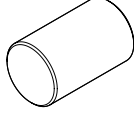
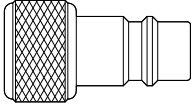
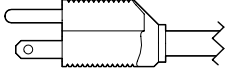
Calibration Check Weight 533 g (1.18 lb)	
Low-side Connection Port Assembly	
Power Cord	
Pouch containing SDSs, EPA information, MACS information, and a service center list.	

## Power Up the Machine

1. Install the power cord into the receptacle on the unit.
2. Plug the power cord into a grounded outlet of the correct voltage.
3. Position the machine so the plug and the power switch are of easy access for the operator. Verify the fan vents on the rear of the machine are not obstructed.
4. Lock the front wheels.
5. Toggle the power switch on the control panel to turn the machine ON.

The machine launches into the initial Setup mode.

## Tank Installation

A 50-lb DOT-4BA-400 tank with an air purge port must be installed for this unit to function. Using a different tank can result in degraded system function. Using a smaller tank can result in accidental tank overflow and potential injury. Discard the plastic surrounding the tank included with this unit and install by completing the following procedure.

1. Open the vapor valve on the tank to purge the 5 to 10 psi of nitrogen that ships with the tank to prevent contamination. Vent the nitrogen to atmosphere and close the valve once venting is complete. The tank will vacuum to purge the remaining nitrogen during initial setup.
2. Place the tank on the scale in the orientation shown in Figure 1. Tighten the thumb screw on the scale.
3. Loop the tank retention strap through the tank handle and secure the clip back to the strap ring. See Figure 1.
4. Remove the bubble wrap from the tank hoses ends and connect the hoses to the appropriate ports on the tank. Open the tank valves after connecting the hoses.

*Note: Incorrect installation of the hoses may result in degraded machine function.*

Figure 2 shows the appropriate configuration for 34888HD.

- Red Hose – Vapor port on tank
  - Blue Hose – Liquid port on the tank
  - Yellow Hose – Air purge port on the tank
5. Remove the temperature probe assembly and strap from its packaging and install on the tank. The unit will not function properly without the tank temperature probe. See Figure 1 for the correct probe position.
    - Place the tank temperature probe assembly in contact with the tank slightly above the mid-line tank weld. Metal to metal contact between the probe and tank is required for accurate tank temperature measurements.
    - Secure the probe assembly to the tank with the probe strap included.

*Note: Do not allow the power cord, service hoses, or any other component to come into contact with the tank during operation. This may influence the scale readings and affect charge or recovery accuracy.*



**WARNING:** To prevent personal injury while working with refrigerant, read and follow the instructions and warnings in this manual, and wear protective equipment such as goggles and gloves.

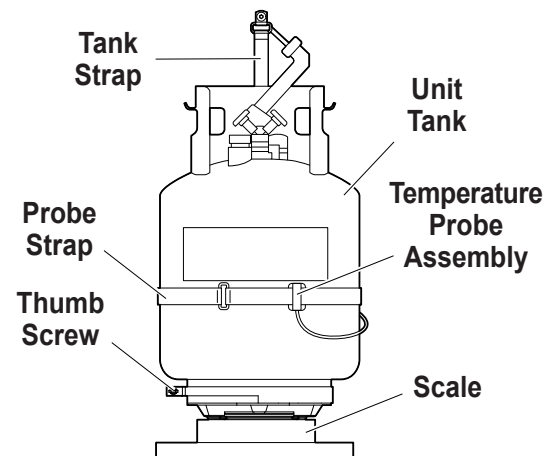

**Figure 1**

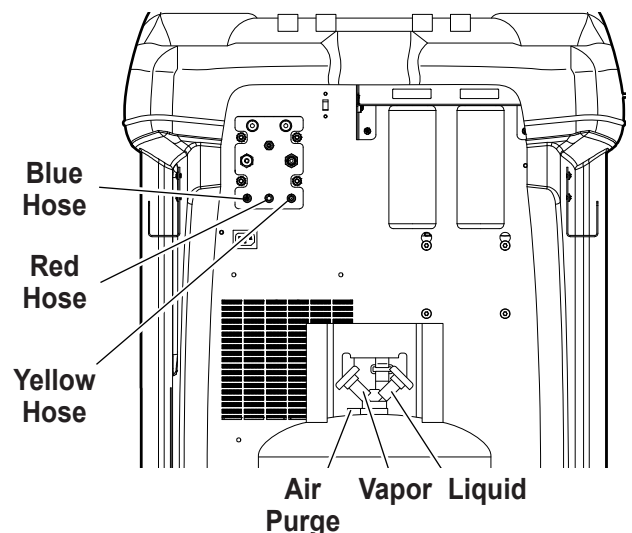

**Figure 2**



# Initial Setup

---

## Select Language

The operator selects the language for the screen prompt displays. English is the default language.

1. Use the **UP** or **DOWN** arrow key to toggle through the available languages one line at a time.
2. Select ✓ to set the selected language.

*Note: To update an existing language or to add a new language, refer to Load Language in the Maintenance section of this manual.*

## Approve Licensing Agreement

Review the licensing agreement at the end of this manual and select ✓ to agree.

## Select Units

The operator sets the display for units of measure. Metric is the default.

1. Use the Arrow UP or Arrow Down key to toggle Imperial or Metric units.
2. Select ✓ to choose the displayed unit of measure.

## Set Date and Time

Use the arrow keys to move the cursor. Use the keypad to modify the information displayed.

1. Use the Arrow up and Arrow Down keys to select which item to change: day, month, year, or time. Select I/O to toggle between AM and PM.
2. Use the multi-tap interface on the numeric keypad to modify the information.
3. Select ✓ to save.

## Edit Print Header

This function allows the user to customize the print header. The information loaded into Edit Print Header will appear on each printout.

1. Enter text by using the arrows and the multi-tap interface on the numeric keypad:
  - **ARROW LEFT** and **X** key act as backspace key.
  - **ARROW RIGHT** moves the cursor to the right.
  - **0 (ZERO)** acts as a space bar when pressed twice.
  - **ARROW UP** and **DOWN** navigate between the rows.
2. Select **✓** to save/exit the function; select **X** to return to the previous header without saving data.

## Service Vacuum

At this point the machine clears its internal plumbing before proceeding with setup.

1. Check the vacuum pump oil level sight glass and verify the oil level is at the center of the sight glass.
2. When prompted, connect the service hoses from the machine to their storage ports as shown in Figure 3. Verify tank hoses are connected and valves are open. Select **▶▶** to continue.
3. The machine enters a 15-minute vacuum and will automatically enter the next set-up process when complete.



**WARNING:** To prevent personal injury while working with refrigerant, read and follow the instructions and warnings in this manual, and wear protective equipment such as goggles and gloves.

Service Hoses  
Connected to  
Storage Ports

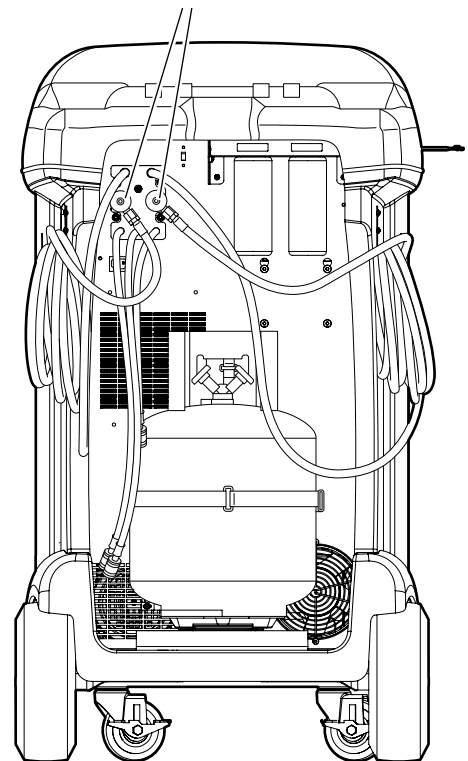

**Figure 3**

# Initial Setup

---

## Tank Fill

This procedure transfers refrigerant from a source tank to the tank on the machine. The maximum capacity of the tank is 20 kg (44 lb). Use arrow keys to move the cursor; use the keypad to enter a value.

1. The machine displays fields for desired tank fill amount, charge capacity, and the amount of recoverable refrigerant (recover capacity) within the tank. Enter the desired tank fill amount.

*Note: Add at least 2.10 kg of refrigerant, in addition to the desired charge amount, to ensure sufficient refrigerant for charging.*

2. Install the 1/2-in. ACME to low-side adapter on the source tank and connect the blue service hose to the adapter.

*Note: Some source tanks have different valve configurations. Be sure to connect the blue hose to the liquid valve. The valve may be red on some tanks and blue on others.*

3. Position the source tank in such a way that liquid refrigerant is supplied to the connection.
  4. Open the source tank valve.
  5. Select ✓ to start the tank fill process. The machine begins filling the tank. Add at least 2.1 kg of refrigerant to ensure enough is available for charging. This process takes 5–40 minutes.
  6. The machine stops when the designated amount of refrigerant has been transferred to the tank or when the source tank is empty. Follow the messages on the display.
  7. Close the source tank valve.
  8. Select ✓ to return to the Setup Menu.
  9. Once complete, shut the valve on the source tank and remove the hose.
  10. Select ►► to recover any refrigerant remaining in the hose.
- The machine is ready for operation.

*Note:*

- *There is no need to calibrate the scale; it is calibrated at the factory.*
- *After the tank fill process is complete, the display does not show the same amount as the programmed fill level.*

*The display shows the amount of refrigerant that is available for charging, which is approximately 2.10 kg (4.6 lb) less than the total amount of refrigerant in the tank.*



**WARNING:** To prevent personal injury while working with refrigerant, read and follow the instructions and warnings in this manual, and wear protective equipment such as goggles and gloves.

*Note:*

**Charge Capacity:** *The amount of refrigerant in the tank that can be charged into an A/C system.*

**Recover Capacity:** *The amount of additional refrigerant that could be recovered into the tank.*

## Unit Activation

Failure to register and activate the machine within 30 days of initial startup will cause the machine to lock out and no longer function.

1. Select Unit Activation from the Setup Menu. The machine displays

---

XX Days Left on Trial  
Period to activate unit.  
Activate Now?

---

2. Select  to start the activation process. The machine displays

---

Product Activation

Personal product code:  
XXXXXXXXXXXX

Enter code:  
XXXXXXXXXXXX

---

3. Open a web browser on a personal computer and enter.
4. Enter the user name and password, and log in to the website.  
*Note: If a first-time user, select REGISTER to create a user name and password.*
5. On the personal computer, enter the Personal Product Code of the machine into the Product Activation key box on the website to receive an activation code.
6. On the machine, enter the activation code into the correct field. Note: Enter the code exactly as received. Capitalization is required.
7. Record the activation code on a piece of paper and file it in a secure place. Select .
8. The machine displays

---

Activation successful.

---

Select **▶▶**. The machine has been activated.

# Operating Instructions

---

## Enter Service Data

After selecting any service function, information about the A/C system may be entered into and stored in the machine's database.

The machine displays

---

Enter service data new

---

1. Select ✓ to enter a new record, or scroll to select a previously serviced A/C system and then select ✓. The highlighted selection will be in red. The machine displays
- 

2. Use the arrow keys to move between rows and the multi-tap keypad to enter text.

Information entered on this screen is stored by date and identification number or vehicle identification number (VIN). The database stores the latest 25 entries, with the most recent at the top of the list.

The information will also appear on service summary printouts.



## Recover Refrigerant from A/C System

1. Empty the oil drain bottle before starting a recovery. Remove the oil drain bottle by unscrewing it from the unit. Reinstall the oil drain bottle. Refer to Figure 4.

*Note: Use caution when removing/installing oil drain bottle. Excessive force may damage internal load cell.*

2. Connect the high-side (red) and low-side (blue) service hoses to the A/C system.
3. Open the coupler valves on the hoses by turning the collars clockwise.
4. Select **RECOVER**  from the **MAIN MENU**.

5. The machine will enter the service data entry form. Enter all applicable data and select  to continue.

6. The machine will ask whether to record diagnostic pressures. Select  to continue recovery process or select  to record operating pressures of the A/C system. Follow on-screen prompts and system service manual specifications to continue.

The machine begins the recovery process. A clicking noise indicates the solenoid is opening and closing — this is normal.

The machine runs a self-clearing cycle to clear any internal refrigerant from its internal plumbing.

System recovery begins and includes a timed vacuum, deep recovery process.

After recovery, the machine will perform an oil drain, which may require up to 90 seconds to complete.

7. After the oil drain is complete, a summary is displayed showing the total amount of refrigerant and oil recovered. Recovery information and pre-recover diagnostics can be printed by selecting . Select **▶▶** to return to the Main Menu.

### Notes:

- *The displayed recovered weight can vary depending on ambient conditions and should not be used as an indicator of scale accuracy.*
- *Depending on the capacity of the system the recovery process may be interrupted if the oil drain bottle is full and needs to be emptied.*



**WARNING:** To prevent personal injury while working with refrigerant, read and follow the instructions and warnings in this manual, and wear protective equipment such as goggles and gloves.

Oil Drain Bottle

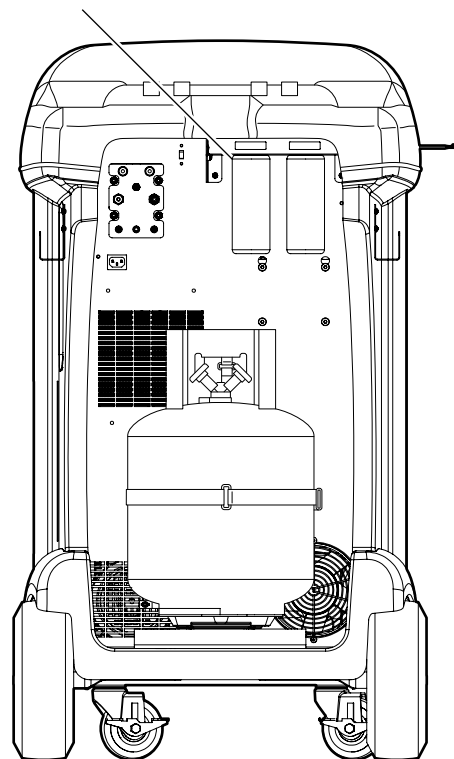



**Figure 4**

# Operating Instructions

---



## Evacuate the A/C System

1. Connect the service hoses to the system's service ports.
2. Open the service hose coupler valves by turning the collars clockwise.
3. Select **VACUUM**  from the **MAIN MENU**.
4. The user will be prompted to enter service data. Once complete, select  to continue.
5. Select Vacuum Leak Check, if desired, to automatically perform a 5-minute pressure rise leak check after the vacuum.
6. Select  to accept the 10-minute default evacuation time, or enter a desired vacuum time using the number keys.

*Note: The vacuum process will halt if pressure rises above .35 bar (5 psi). Recover refrigerant before proceeding.*

The machine pulls a vacuum on the A/C system for the programmed amount of time.

Vacuum information can be printed by selecting  on machines equipped with a printer.

7. Select  to return to the Main Menu.



**WARNING:** To prevent personal injury while working with refrigerant, read and follow the instructions and warnings in this manual, and wear protective equipment such as goggles and gloves.



## Flushing the Hoses

If the next system to be serviced contains a different type of oil than the previous system serviced, it is recommended the service hoses be flushed of residual oil to prevent contamination.

1. Select **FLUSH HOSES** from the **SETUP MENU**. The machine displays

---

Connect service hoses to storage ports and open coupler valves.

---

2. Connect the service hoses to the machine's storage port connections as shown in Figure 5.
3. Open the service hose coupler valves by turning the collars clockwise.
4. Select  to begin the hose flush process, which runs for three minutes, followed by a recovery.

When the hose flushing process is complete, the display reads

---

FLUSH HOSES  
Complete

---

5. Select **▶▶** to return to the Setup Menu.
6. Close the coupler valves by turning the collars counterclockwise.

Service Hoses  
Connected to  
Storage Ports

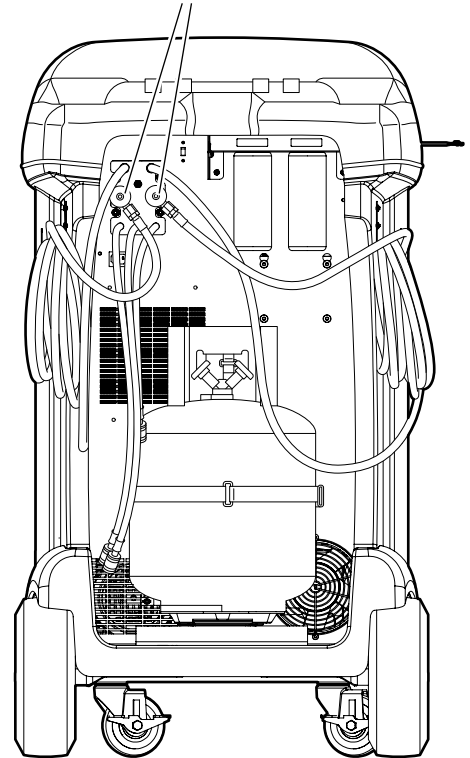

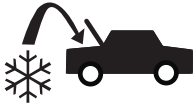

**Figure 5**

# Operating Instructions







## Recharge the A/C System

1. Connect both service hoses to the system's service ports.
2. Select **CHARGE**  from the **MAIN MENU**.
3. The user will be prompted to enter service data. Select  once complete to continue. The display shows

---

Charge: XX.XXX kg                      on High Side  
Oil Amount: XXX ml  
Min Charge quantity 10g

---

4. Use the arrow keys and the numeric keypad to enter the desired charge amount. Select **kg|lbs|oz** to change units.
5. Using the arrow keys, maneuver to the charge path selection. High Side is default. To change, select **HSL** on the control panel. This will allow the user to toggle between high, low, and both side charge paths. The current selection is indicated on the display.
6. Oil can also be injected into the system during the charge. Use the numeric keypad to enter the desired oil inject amount. Select **ml|oz** to change units. Make sure there is available oil in the inject bottle located on the rear of the machine.
7. Select  to start the charge process. Moving or bumping the machine at this point may result in an inaccurate charge. When the charge cycle gets close to the desired weight value, the machine slows down. It will charge, settle, charge again, settle, etc. When charge is complete, the user will be given the option to perform system diagnostics.
8. When prompted, select  to perform hose equalization.
9. The user will be prompted to close the coupler valves and disconnect the hoses from the system. Select  to recover any remaining refrigerant from the hoses.
10. When the **CHARGE COMPLETE** screen appears, it includes a summary of charge results. Select  to print the summary. Select  to proceed to clear the service hoses. Once the hose clear is complete, the machine will return to the Main Menu.

The A/C system is now ready for use.



**WARNING:** To prevent personal injury while working with refrigerant, read and follow the instructions and warnings in this manual, and wear protective equipment such as goggles and gloves.

*Note: The charging process differs from system to system. Charge function for systems equipped with a single service fitting should be carried out manually. Refer to the system service manual for specific instructions.*

---

**CAUTION:** If the low-side (blue) or high-side (red) coupler valve is left open during the hose clearing process, the system will pull refrigerant back out of the A/C system.

---



## Automatic Function

The **AUTOMATIC** function allows a user to perform an automatic recovery, vacuum, leak test, and/or charge sequence. A total automatic sequence may require an extended period of time to complete.

1. Connect high-side (red) and low-side (blue) service hoses to the A/C system.
2. Open the service hose coupler valves by turning the collars clockwise.
3. Select **AUTOMATIC**  from the **MAIN MENU**. The display shows:





---

Vacuum Time: XX:XX  
Vacuum Leak Test: ON  
Charge: XX.XXX kg                      on High Side  
Additional Oil: XXX ml  
Min Vacuum time is 1 sec

---

4. Use the numeric keypad to enter the desired length of vacuum.
5. Using the arrow keys, maneuver downwards to choose whether to perform a vacuum leak test or not. ON is the default setting. To toggle, select **I/O** on the control panel.
6. Using the downwards arrow key, maneuver to the “charge amount” entry field. Use the arrow keys and numeric keypad to enter the desired charge amount. Select **kg|lbs|oz** to change units.
7. Using the arrow keys, maneuver to the “charge path selection.” High Side is default. To change, select **HSL** on the control panel. This will allow the user to toggle between high, low, and both side charge paths. The text on the display will change to the current selection.
8. Using the arrow keys, maneuver to the “additional oil” entry field. Use the numeric keypad to enter the desired additional oil inject amount. Select **ml|oz** to change units. Make sure there is available oil in the oil inject bottle located on the rear of the machine.

*Note: Additional oil amount specified is in addition to the amount recovered. If no additional oil is specified, the machine will inject the same amount of oil as was recovered (automatic mode only).*

9. Select  to begin the **AUTOMATIC** cycle. The unit will now automatically proceed through all applicable functions: **RECOVER**, **VACUUM**, and **CHARGE**. The system will automatically skip steps not required.
10. The user will be prompted to close the coupler valves and disconnect the hoses from the system. Select  to recover any remaining refrigerant from the hoses.
11. When the **AUTOMATIC COMPLETE** screen appears, it includes a summary of results. Select  to print the summary. Select  to proceed. Once the cycle is complete, the machine will return to the Main Menu.

The A/C system is now ready to use.

### Notes:

- The **CHARGE** function for systems equipped with a single-service fitting should be carried out manually according to procedures in the manufacturer’s service manual.
- If **RECOVER** was not performed, the amount of oil to be injected may be entered while programming the **CHARGE** information.
- If problems are encountered during the automatic sequence, an audio alert sounds three times. The sequence remains paused until the user enters a decision regarding how to proceed.

# Operating Instructions

## System Flush

The **SYSTEM FLUSH** function is performed using a manufacturer-approved flushing adapter. Refer to the instructions included with the adapter while the following steps are performed.

1. Verify the flusher filter and strainer are not plugged.
2. Mount the flusher per the manufacturer's recommendation.
3. Dispose of any oil in the drain bottle according to applicable regulations. See Figure 6.

4. Recover all refrigerant from system to be flushed.

*Note: A system flush removes all oil in the system. Replace oil per the manufacturer's recommendation.*

5. Verify there is sufficient refrigerant in the machine. The machine will not be able to complete a system flush without enough refrigerant in the tank to allow liquid to flow through the system.
6. Disconnect the machine from the system.
7. Refer to the system service manual, and connect the appropriate flushing adapters and bypasses.
8. Connect the low-side (blue) service hose directly to the outlet of the flushing kit to protect the ACS machine.
9. Remove the high-side (red) service coupler, and connect to the flushing adapter inlet.
10. Connect hoses according to the instructions included with the flush kit.

---



**CAUTION:** To prevent damage to the ACS machine, ensure that the flushing adapter has a filter or screen to remove any debris from the A/C system.

---

11. Select **SYSTEM FLUSH** from the **SETUP MENU**. The unit will prompt for any service data entry, if desired. Select  to continue to the system flushing process. The user will be prompted to enter in a Flush Time.

The machine will then automatically enter the **VACUUM** process and proceed to a leak test.

Once the vacuum and leak tests are completed, the unit will enter the system flushing process, followed by an oil drain.

12. When the Flush Complete screen appears, it includes a system flush result summary. Select  to print the summary. Select  to return to the **SETUP MENU**.

The A/C system has been flushed.



---

**WARNING:** To prevent personal injury while working with refrigerant, read and follow the instructions and warnings in this manual, and wear protective equipment such as goggles and gloves.

---

---

**! WARNING:** Do NOT disconnect service couplers during the flushing process. Refrigerant could spray out of the fittings, and exposure may cause personal injury.

---

Oil Drain Bottle

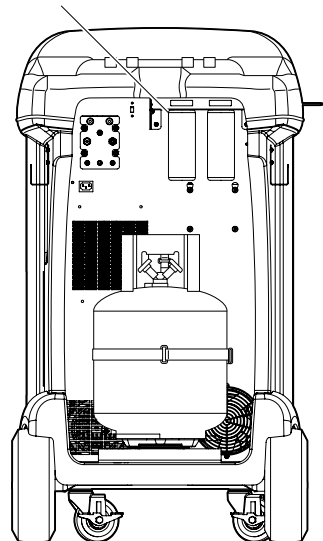

**Figure 6**

---

**CAUTION:** The flushing kit must have a replaceable filter as well as a debris strainer, both of which can become plugged. At the end of the flush cycle, check the high-side (red) gauge for system pressure, and check the adapter for complete removal of refrigerant.

If pressure exists or refrigerant remains, exit the flushing cycle and enter the recovery mode to recover refrigerant through both the high-side (red) and low-side (blue) hoses. Then service the filters and repeat the flush process.

---

## N2 and N2H2 Leak Test

This unit has the ability to pressurize an A/C system with N2 or N2H2 for the purpose of leak detection. A separate, optional, leak detection kit is required.

1. Connect the high-side (red) and low-side (blue) service hoses to the A/C system. Open the coupler valves on the hoses by turning the collars clockwise. Do not attempt to remove these connections while pressurized during the N2 or N2H2 leak test.
2. Adjust the N2 or N2H2 supply tank regulator to an output of 6–9.5 bar. Do not exceed 9.5 bar of pressure and ensure N2H2 has H2 content <5%. N2 or N2H2 supply tanks are not included with this unit.
3. Connect the supply tank to the port on the ACS unit as shown in Figure 7. This port utilizes a ¼" flare fitting per SAE J513.
4. Select **N2LEAKTEST** from the **MAIN MENU**. The machine will enter to service data entry form. Enter the applicable data and select ✓ to continue. Use the control arrows to select N2 Leak Test or N2H2 Leak Test and select ✓ to continue
5. Follow on-screen prompts and the system service manual specifications to continue. Select ►► to proceed with the test. The machine begins to pressurize the system.
  - For the N2 Leak Test, the machine monitors system pressure and records any decay indicative of a leak.
  - For the N2H2 Leak Test, the user will be prompted to use a leak detector to search for leaks and enter the results back into the system.
6. Upon completion of the leak test, a summary of the results is displayed. Select 🖨 to print the results or ►► to continue and vent N2 or N2H2 from the system. The vacuum pump is engaged to assist in purging N2 or N2H2 from the system. After venting is complete, select ►► to return to the main menu.



**WARNING:** To prevent personal injury while working with refrigerant, read and follow the instructions and warnings in this manual, and wear protective equipment such as goggles and gloves.

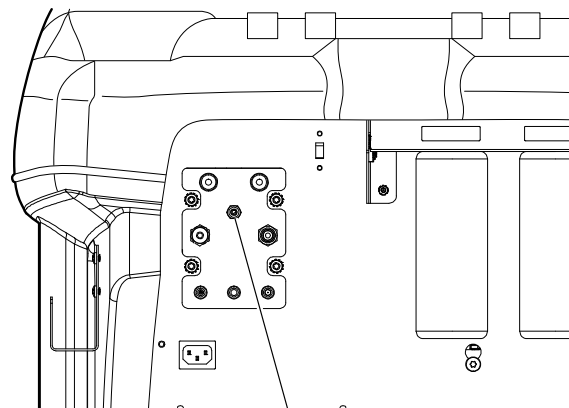

N2 and  
N2H2 Port

**Figure 7**

---

**⚠ WARNING:** Do NOT use air or any gas besides N2 or N2H2 to pressurize the system. Mixtures of air and refrigerant can be combustible at elevated pressures. These mixtures are potentially dangerous and can result in fire or explosion causing personal injury and/or property damage.

---

# Maintenance

## Maintenance Schedule

Maintenance Task	Recommended Interval
Change filters	After 136 kg (300 lb) of refrigerant has been filtered. Refer to Filter Maintenance in the Maintenance section of this manual.
Change vacuum pump oil	When the filter is replaced. Refer to Change Vacuum Pump Oil in the Maintenance section of this manual.
Check casters and wheels for ease of operation	Monthly.
Check internal scale calibration	Monthly. Refer to Calibration Check in the Maintenance section of this manual.
Check machine for leaks	Monthly. Check hoses and connections for leakage. Disconnect power, remove the door screws, open the door, and use an electronic leak detector to check fittings.
Clean airflow outlet panel (see Figure 8)	Monthly. Use a clean cloth.
Clean cabinet and control panel	Monthly. Use a clean cloth.
DOT tank inspection	Verify DOT tank inspection
Inspect power cord and hoses for cuts and abrasions	Daily.
Pressure test	Every 10 years. Performed by an authorized Robinair service center.

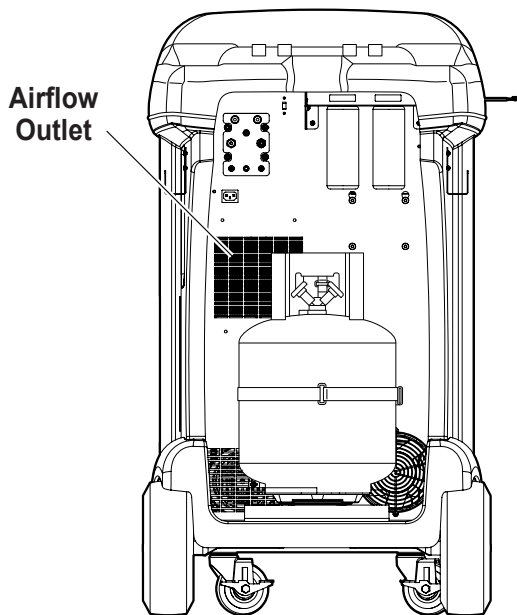

**Figure 8**



**WARNING:** To prevent personal injury only qualified personnel may perform inspections and repairs to this machine. Read and follow instructions and warnings in this manual, and wear protective equipment such as goggles and gloves.



## Load Language

Use the following instructions to add or update a language from an SD card.

1. Turn the machine off. Remove the door access screws from the right side of the unit and open the door.
2. Remove the top panel retention screws and rotate the top panel about its hinge to access the SD card slot on the control panel. See Figure 9.
3. Insert the SD card containing the language data into the port on the control board. Rotate the top panel back to its original, closed position.
4. Turn the machine power on. Choose **SELECT LANGUAGE** from the **SETUP MENU**.
5. Use the arrow keys to scroll to **LOAD NEW**. Select **✓**.
6. Follow the prompts to select the language to load or update. If loading a new language, it will be necessary to select which language to replace.
7. Once the process is complete, turn the machine power off and remove the SD card. Re-install the top panel retentions screws and the door access screws.

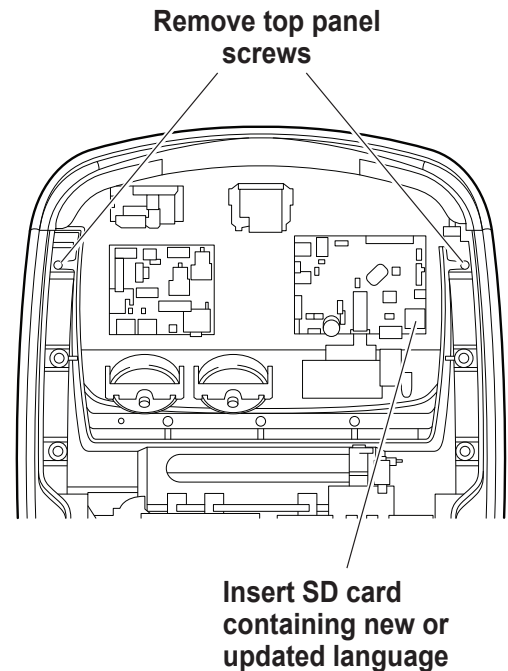

**Figure 9**

## Edit Print Header

To make changes to text that appears in this screen:

1. Select **EDIT PRINT HEADER** from the **SETUP MENU**.
2. The cursor is in the first field. Update the text by using the arrows and the multi-tap interface on the numeric keypad:
  - **ARROW LEFT** and **✕** act as a backspace key.
  - **ARROW RIGHT** moves the cursor to the right.
  - **ZERO (0)** key acts as a spacebar.
  - **ARROW UP** and **DOWN** navigate between the rows.
3. Select **✓** to save the changes and return to the Setup Menu; select **✕** to return to the previous header and exit to the Setup Menu.

## Replace Printer Paper

To install a new paper roll in the printer:

1. Remove the cover on the printer by pulling out on the tab as shown in Figure 10.
2. Remove the paper core.
3. Install the new roll of paper with the end of the paper at the top of the roll.
4. Assemble the cover onto the printer with the leading edge of the paper over the roller.

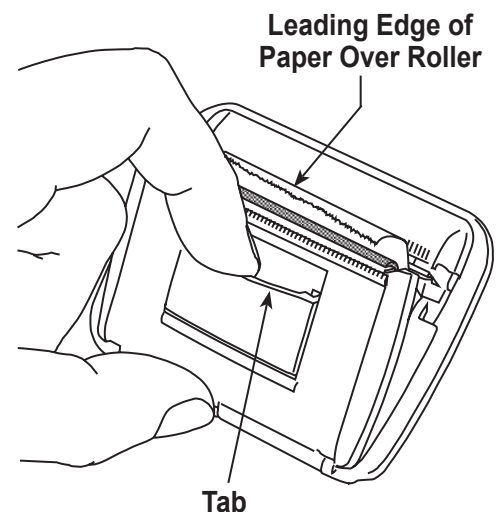

**Figure 10**



# Maintenance

---

## Filter Maintenance

The filter is designed to trap acid and particulates, and to remove moisture from refrigerant. To meet the mandate for adequate moisture and contaminant removal, the filter must be replaced after 136 kg (300 lb) of refrigerant has been filtered.

The machine gives a warning when 91 kg (200 lb) of the filter capacity has been used; the machine locks down when the 136 kg (300 lb) filter capacity has been reached and will no longer function.

### Check Remaining Filter Capacity

1. Select **FILTER MAINTENANCE** from the **SETUP MENU** or when the machine prompts. The machine displays

---

Remaining Filter Capacity: XXX.XO kg  
Replace filter now?

---

The machine displays the amount of filter capacity remaining until the machine locks down.

2. Select ✓ to change the filter; select ✗ to resume using the machine.

---

**⚠ WARNING: The components in the machine are under high pressure. To prevent personal injury, change the filter only when the machine prompts.**

---



**WARNING: To prevent personal injury while working with refrigerant, read and follow the instructions and warnings in this manual, and wear protective equipment such as goggles and gloves.**

## Replace the Filter

1. If ✓ was selected to change the filters, the machine prompts for the new filter codes to be entered. One or two filter serial numbers may be entered depending on how many filters are replaced. If one filter is replaced, 68 kg (150 lb) of capacity is added to the machine. If both filters are replaced, 136 kg (300 lb) of capacity is added.

Use the keypad to enter the serial number(s) that appears on the new filter(s), and select ✓ to continue.

*Note: If "Invalid serial number" is displayed, the serial number has been incorrectly entered, or the filter has already been used in this machine.*

2. The machine clears the existing filter and displays:

---

Serial numbers accepted.

Turn power off and replace filters.

---

Turn off the machine. Remove the two door screws and open the door. See Figure 11.

3. Remove the filters by turning them counterclockwise (as viewed from the bottom of the filter).
4. Look at the new filters. Verify both o-rings are lubricated and correctly located in the grooves.
5. Install the new filters by threading them clockwise into place. Verify the filters are positioned correctly as shown in Figure 11. Tighten both filters to 20 Nm.
6. Power the machine on. The Change Vacuum Pump Oil operation will begin, and the screen will display

---

Warming oil for drain XX:XX

---

See the **CHANGE VACUUM PUMP OIL** section of this manual for more information.

The machine will then begin the Leak Check operation. See the **LEAK CHECK** section of this manual for more information.

---

**CAUTION:** To prevent equipment damage, use only authentic Robinair No. 34724 filters in this machine. All performance tests and claims are based on using this specific filter.

---

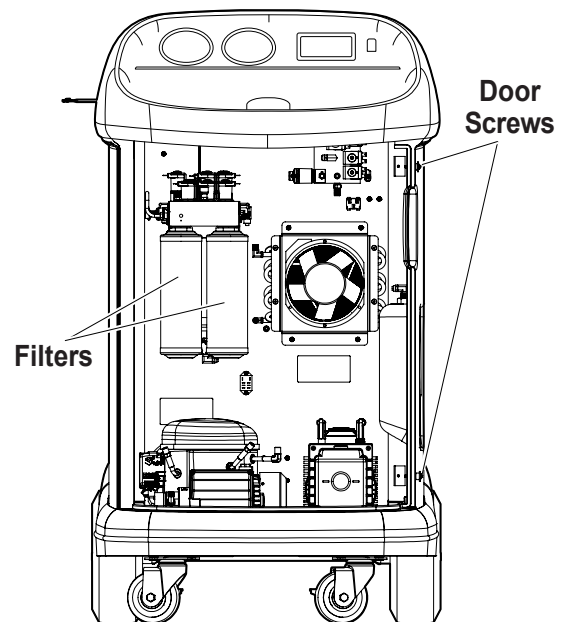

**Figure 11**

# Maintenance

---

## Calibration Check

This function is used to ensure the machine's scale is always calibrated. During this test, use only the calibration weight that is provided with the machine.

1. Select **CALIBRATION CHECK** from the **SETUP MENU**.  
The machine displays

---

Place calibration weight on the top of the tank.

---

2. Place the calibration weight on the tank near the valves.  
Select ✓ to continue.

The machine displays

---

Remove calibration weight from the tank.

---

3. Remove the calibration weight from the tank. Select ✓ to continue.

4. If the machine displays

---

Calibration check passed

---

the scale is in calibration. Select ►► to return to the setup menu.

5. If the displays

---

Calibration check failed. Retry?

---

the scale is out of calibration. To retry, select ↺. If the calibration continues to fail, contact an authorized Robinair service center for assistance.

## Change Vacuum Pump Oil

1. Select **PUMP MAINTENANCE** from the **SETUP MENU** or when prompted. The display show how long the vacuum pump has operated since the last oil change.

---

Oil life remaining:  
XXX:XX (hhh:mm)  
Change oil now?

---

2. Select  to change vacuum pump oil The machine displays

---

Warming oil for drain  
XX:XX

---

allow the vacuum pump to run for two minutes to warm up the oil for more effective drainage.

3. Remove the door access screws from the right side of the unit and open the door.
4. Slowly open the oil fill cap to verify there is no pressure in the machine. Then carefully remove the cap. See Figure 12.
5. Remove the oil drain fitting cap and drain the oil into a suitable container for disposal. Dispose of the oil according to applicable regulations. Replace the drain fitting and close tightly. Add 225 mL of new vacuum pump oil and select **▶▶** to continue.
6. The machine displays

---

Fill vacuum pump to the center of the sight glass  
Reinstall fill cap

---

Slowly add vacuum pump oil to the pump through the oil fill port until the oil reaches the center of the sight glass. Install the cap on the oil fill port and close tightly. Select **▶▶** to return to the **SETUP MENU**.

*Note: For proper oil level, ensure the machine is on a flat, level surface.*

---

**CAUTION: It is the responsibility of the user to monitor vacuum pump oil level and clarity. If contaminated oil is not removed from the vacuum pump and replaced, the vacuum pump will be permanently damaged.**

---



**WARNING:** To prevent personal injury while working with refrigerant, read and follow the instructions and warnings in this manual, and wear protective equipment such as goggles and gloves.

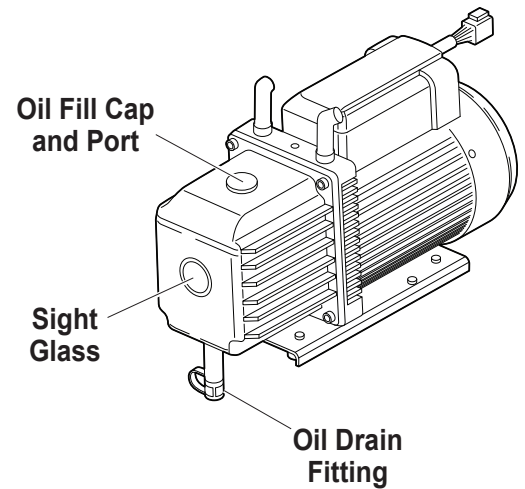

**Figure 12**

# Maintenance

## Empty Vacuum Pump Exhaust Bottle

A vacuum pump exhaust bottle is included with this unit, as shown in Figure 13, to capture any oil that may be expelled from the pump. The bottle should be emptied anytime a noticeable amount of oil accumulates.

1. Unscrew the bottle to remove it from the unit.
2. Dispose of the oil according to local, state, and federal regulations.
3. Check the vacuum pump sight glass to confirm that the oil level is sufficient. Refer to the **CHANGE VACUUM PUMP OIL** section of the manual for instruction to change or add vacuum pump oil.
4. Reinstall the empty vacuum pump exhaust bottle.

## Tank Removal

To protect the scale from damage, the tank must be removed from the unit any time the unit is transported. Follow these steps to remove the tank.

1. Close the liquid and vapor valves on the tank and disconnect the tank hoses from the tank.
2. Unfasten the probe strap and remove the temperature probe assembly from the tank. Secure the temperature probe during transport.
3. Untether the tank by releasing the tank strap clip and pulling the strap through the tank handle.
4. Loosen the thumbscrew on the scale and remove the tank by lifting up.

*Note: The nitrogen must be purged and the tank pulled into vacuum before a new tank can be used.*

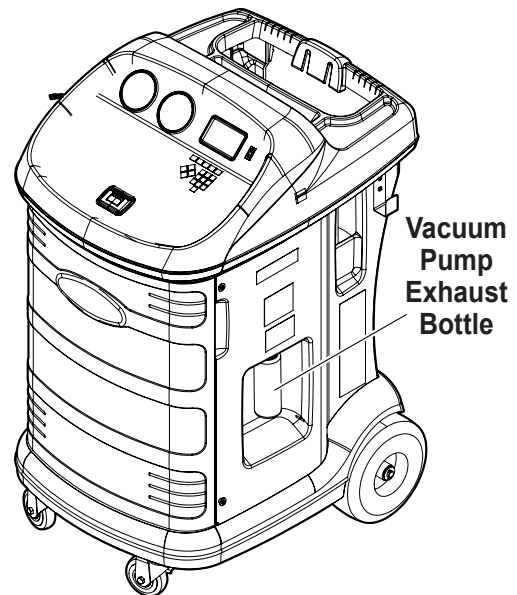

**Figure 13**



**WARNING:** To prevent personal injury while working with refrigerant, read and follow the instructions and warnings in this manual, and wear protective equipment such as goggles and gloves.

## Leak Check

A leak test may be performed on the machine at any time. During this test, components containing refrigerant are pressurized and monitored for pressure decay, which could indicate a leak.

1. Select **LEAK CHECK** from the **SETUP MENU**. The machine displays

---

Connect service hoses to storage ports and open coupler valves

---

2. Connect the service hose couplers to the storage ports at the rear of the machine. Open the couplers by turning the collars clockwise.
3. Select  to start. The machine performs a self-recovery and displays

---

Recover in progress

---

The machine performs a 30-second vacuum test and displays

---

Vacuum leak check in progress

---

If the vacuum test fails, the machine will prompt to check for leaks.

Once the machine passes the vacuum test, a controlled pressure is applied to its internal components. The machine displays

---

Pressure leak check in progress

---

Pressure is held for five minutes and monitored for decay. Minutes and seconds count down on the display.

- If an acceptable pressure decay is detected, the machine recovers refrigerant and returns to the Setup Menu, ready for normal operation.
- If an unacceptable pressure decay is detected, the machine will prompt to check for leaks. Contact an authorized Robinair service center for repair.

---

---

 **WARNING:** To prevent personal injury, do **NOT** operate the machine at any other time without the oil fill port cap installed, because the vacuum pump is pressurized during normal operation.

---

---

---

---

 **WARNING:** To prevent personal injury should the machine require transport to a local Robinair service center, follow local government regulations regarding transportation of equipment containing R-134a.

---

---

# A/C Service Functions

---

## Replacement Parts

Component	Replacement Part No.
Calibration Weight	16214
Filter	34724
Hose Set without Couplers (high-side [red] and low-side [blue])	70130
Oil Bottle	19103
Printer	30038
Printer Paper (3 rolls)	34214
LP Service Coupler	18190A
HP Service Coupler	18191A
Service Coupler Set (high-side [red] and low-side [blue] couplers)	18192
Service Hose (low-side, blue)	70131
Service Hose (high-side, red)	70132
Tank Hose (blue)	70141
Tank Hose (red)	70140
Tank Hose (yellow)	70142
Tank, 50-lb R134a	34750
Vacuum Pump Oil (pint)	13119
Vacuum Pump Oil (quart)	13203
Vacuum Pump Oil (gallon)	13204
Vinyl Dust Cover (optional)	17490
1/2-in. ACME to low-side adapter	16301

---



---

 **WARNING:** To prevent personal injury, use only those repair parts called out in this parts list. Items found in this parts list have been carefully tested and selected by Robinair.

---





---

# Troubleshooting

Display	Cause	Solution
AIR PURGE ERROR DUE TO EXCESSIVE PURGE TIME	Possible poor sensor contact with tank.	Verify tank temp sensor is properly connected to the tank.
CALIBRATION CHECK FAILED	Tank scale is out of calibration.	Select  to retry calibration check. If calibration continues to fail, exit current test and contact a Robinair authorized service center for repair.
CHARGE STALLED!	Transfer from ACS to machine has stalled. Refrigerant is stalled in the tank or the machine.	Verify connections are secure and valves are in correct position. Verify that the circuit breaker is not tripped.
DATABASE NOT AVAILABLE	Machine is not shipped with database installed.	Contact a Robinair authorized service center for more information.
EXCESS TANK WEIGHT	Overfill safety circuit tripped. Machine is locked out because of too much refrigerant in tank.	Contact a Robinair authorized service center for more information.
FILTER CAPACITY EXHAUSTED, FILTER MUST BE REPLACED FILTER WEIGHT XXX.XYY REPLACE FILTER NOW?	136 kg (300 lb) or more refrigerant has been recovered since last filter change.	Refer to Filter Maintenance section of this manual for instructions to change filter.
FILTER SERIAL NUMBER HAS ALREADY BEEN USED. RE-ENTER OR EXIT	Filter serial number entered into the machine is not correct.	Filter has already been used on this machine. Obtain new Robinair filter No. 34724.
HIGH TANK PRESSURE	Machine is locked out because pressure in tank is too high, possibly because of high tank temperature or excess air in tank.	Allow machine to cool before performing additional A/C service. If problem continues, contact a Robinair authorized service center for more information.
INLET PRESSURE IS TOO HIGH FOR VACUUM	Before the machine begins evacuating the A/C system, it checks for pressure in the system that could damage the vacuum pump. In this case, system pressure is above 0.35 bar gauge.	Select  . Refer to Recover section of this manual to recover refrigerant before proceeding.



# Troubleshooting

Display	Cause	Solution
INSUFFICIENT REFRIGERANT. 6.00 KG REQUIRED FOR SYSTEM FLUSH	Not enough refrigerant in the tank to perform a system flush.	<i>Refer to Tank Fill in Maintenance section of this manual.</i>
INSUFFICIENT REFRIGERANT AVAILABLE FOR CHARGE SELECTED: XX.XXYY AVAILABLE: XX.XXYY	After a desired weight is entered, if the charge process will leave less than 2.10 kg (4.6 lb) of refrigerant in tank, the charge function will not start.	<i>Refer to Tank Fill in the Maintenance section of this manual.</i>
INVALID CODE	Activation code entered into the machine is not correct.	<i>Verify activation code is entered exactly as received. Capitalization is required.</i>
INVALID SERIAL NUMBER!	Filter serial number entered into the machine is not correct.	<i>Verify serial number entered matches serial number on filter. Verify filter has not been used on machine previously.</i>
LEAK TEST FAILED	A leak in the A/C system.	<i>Exit current test and perform repairs on A/C system.</i>
NO PRESSURE ON INLETS CHECK CONNECTIONS RECOVER ANYWAY?	System pressure is below 0.35 bar gauge.	<i>Verify high-side (red) and low-side (blue) hoses are connected and coupler valves open. Select  to RECOVER; select  to bypass recover and proceed to VACUUM.</i>
OIL DRAIN HALTED	Accumulator pressure failed to rise above 1.10 bar within the minute before an oil drain was supposed to occur. Unit failed to drain recovered oil because of lack of pressure or an internal obstruction.	<i>Adequate pressure is required within the accumulator to force the oil, which has been separated from the refrigerant, out of the system. Select  to retry; select  to exit.</i>
OIL LIFE REMAINING XX:XXX CHANGE OIL NOW?	Display shows vacuum pump oil life remaining until oil should be replaced.	<i>Refer to Maintenance section of this manual for instructions to change vacuum pump oil.</i>
OUT OF RANGE ACCUMULATORPRESSURE	Accumulator pressure transducer is not reading pressure correctly.	<i>Exit current test and contact a Robinair authorized service center for more information.</i>

# Troubleshooting

Display	Cause	Solution
OUT OF RANGE HS PRESSURE SENSOR	High side pressure transducer is not reading pressure correctly.	<i>Exit current test and contact a Robinair authorized service center for more information.</i>
OUT OF RANGE TANK PRESSURE	Tank pressure transducer is not reading pressure correctly.	<i>Exit current test and contact a Robinair authorized service center for more information.</i>
OUT OF RANGE TANK TEMPERATURE	Tank temperature sensor is not reading temperature correctly.	<i>Move unit to an environment within operating range or exit current test and contact a Robinair authorized service center for more information.</i>
OUT OF RANGE LS PRESSURE SENSOR	Low-side pressure transducer is not reading pressure correctly.	<i>Exit current test and contact a Robinair authorized service center for more information.</i>
POWER BOARD COMMUNICATION FAILED	Failed communication with relay board.	<i>Cycle power. If problem continues, contact a Robinair authorized service center for more information.</i>
PRESSURE LEAK TEST FAILED CHECK UNIT FOR LEAKS	A leak in ACS machine.	<i>Exit current test and identify source with a leak detector.</i>
SOURCE TANK IS EMPTY	Refrigerant cannot be transferred to the tank because the source tank is empty.	<i>Exit current test and replace the source tank.</i>
TANK FULL. REMOVE REFRIGERANT BEFORE CONTINUING	Tank is too full to recover additional refrigerant.	<i>Perform a charge process to remove refrigerant from tank before any further recovery attempts.</i>
TRIAL PERIOD EXPIRED UNIT ACTIVATION REQUIRED TO CONTINUE USE	Failure to register and activate the machine within 30 days of initial startup will cause the machine to lock out and no longer function.	<i>Select ✓ and refer to Unit Activation section in this manual to register the machine.</i>
VACUUM TEST FAILED. CHECK SYSTEM FOR LEAKS	A leak in A/C system.	<i>Exit current test and perform repairs on A/C system.</i>

# Storage and Transportation of Equipment

---

## Storage

Never leave the machine live if an immediate use is not scheduled.

1. Disconnect the machine from its power supply.
2. Loop the service hoses around the handle twice and attach them to the storage ports. See Figure 14.
3. Store the machine in a dry, stable area, away from flames and hot surfaces. The temperature of the storage area should range between  $-18^{\circ}\text{C}$  and  $60^{\circ}\text{C}$  ( $0^{\circ}\text{F}$  and  $140^{\circ}\text{F}$ ).
4. Lock the front wheels.

## Transportation of Equipment

---

**!** **WARNING:** To prevent personal injury, should the machine require transport to a Robinair service center, follow local government regulations regarding transportation of equipment containing R-134a.

---

Service Hoses  
Connected to  
Storage Ports

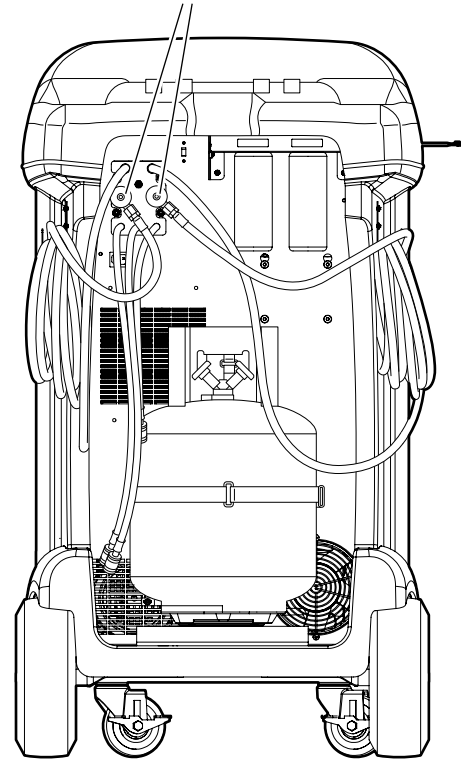

**Figure 14**

# Disposal of Equipment

---



At the end of its useful life, dispose of the R-134a machine according to current government regulations.

- Public administration and producers of electrical / electronic equipment (EEE) are involved in facilitating the processes of the re-use and recovery of waste electrical / electronic equipment through the organization of collection activities and the use of appropriate planning arrangements.
- Do not dispose of this equipment as miscellaneous solid municipal waste. Arrange to have it collected separately. Unauthorized disposal of waste electrical / electronic equipment is punishable by law with appropriate penalties.
- The reuse and correct recycling of electrical / electronic equipment (EEE) is required for the protection of the environment and the well-being of humans.

## Disposal of Recycled Materials

It is the responsibility of the user to determine if a material is a hazardous waste at the time of disposal. The user must ensure compliance with all applicable laws and regulations.

1. Deliver the refrigerant recovered from A/C systems to gas suppliers for recycling or disposal.
2. Deliver the lubricants extracted from A/C systems to used oil collection centers.
3. Review the laws in your jurisdiction to determine correct disposal procedures for pump oil.

## Disposal of the Machine

1. Detach and vent the gas from the machine circuit. Completely discharge the refrigerant tank in compliance with current government regulations.
2. Deliver the machine to an appropriate disposal center.

## Disposal of Batteries



At the end of their useful life, dispose of batteries according to current government regulations. Batteries must be recycled or disposed of correctly. Do not throw away batteries as part of normal refuse disposal.



**WARNING: To prevent personal injury, do not throw batteries into open flame.**

---

---

# Software License Notices

---

## BOSCH AUTOMOTIVE SERVICE SOLUTIONS SOFTWARE LICENSE NOTICES

Copyright © 2014 Robert Bosch GmbH. All Rights Reserved.

Bosch Automotive Service Solutions

This Bosch Automotive Service Solutions software is released under the software license agreement presented at product activation.

All other products or service names are the property of their respective owners.

Registered trademarks of their respective companies and are hereby acknowledged.

The following notices pertain to this Bosch Automotive Service Solutions software license:

1. This product contains IAR Standard libraries. IAR software license agreement is reported below and located. IAR standard library includes third party software as declared in the third party licenses document reported below and located.
2. This product contains LibTomCrypt is a fairly comprehensive, modular and portable cryptographic toolkit that provides developers with a vast array of well known published block ciphers, one-way hash functions, chaining modes, pseudo-random number generators, public key cryptography and a plethora of other routines. LibTomCrypt is public domain. As should all quality software be.  
Tom St Denis
3. This product contains Freescale software as part of the Freescale microcontroller BSP. Refer to the Freescale Semiconductor License Agreements for the use terms below reported and located.

# IAR Software License Agreement

Concerning the Products: IAR Embedded Workbench® and visualSTATE® from IAR Systems AB

## **PREAMBLE**

**THIS SOFTWARE LICENSE AGREEMENT (“THE AGREEMENT”) APPLIES TO PRODUCTS LICENSED BY IAR SYSTEMS AB INCLUDING ANY OF ITS SUBSIDIARIES (“IAR SYSTEMS”) OR DISTRIBUTORS (“IAR DISTRIBUTORS”), TO YOU (“THE LICENSEE”).**

*The order confirmation from IAR Systems, or when applicable the agreement between IAR Systems and the Licensee, will set out, apart from the applicable licensed product and license fee (which will also be stated in the Invoice), a) if the License in question is a PC-locked License or a Multi-user License, b) in case of a Multi-user License with the allowed number of simultaneous users, c) if the license includes a time limited Support and Update Service and in such cases the expiry date of such service. Any opening of a package where these terms have been stated or referred to, and any use of IAR Systems software, is subject to these terms and conditions.*

**YOU AS A USER OF THE LICENSED PRODUCTS STATED ABOVE AND ON THE INVOICE, WILL BIND THE CORPORATION OR ORGANIZATION ALSO SET OUT ON THE INVOICE TO THIS AGREEMENT, BY OPENING OF A PACKAGE OR INSTALLING SOFTWARE WHERE THIS AGREEMENT HAS BEEN STATED OR REFERRED TO. IF YOU ARE NOT IN AGREEMENT WITH THE TERMS HEREIN, OR DO NOT HAVE THE AUTHORITY TO BIND YOUR CORPORATION OR ORGANIZATION TO THESE TERMS, YOU SHALL IMMEDIATELY CONTACT IAR SYSTEMS AND YOU MAY NOT INSTALL ANY SOFTWARE OR MAKE USE OF ANY PARTS OF THE PRODUCT.**

## **1. DEFINITIONS**

The following terms have the meanings set forth below whenever they are used in this Agreement:

- 1.1 **“Executable Software”** means a copy of the executable code version of the software program(s) included in the enclosed package or otherwise specified in this Agreement or Invoice (including any link-time and runtime modules), along with templates and other instructions and any Software updates, revisions, and additional modules and templates (if any) that the Licensee may receive from IAR Systems hereunder from time to time.
- 1.2 **“Software Source Code”** has the meaning set out in section 3.7.
- 1.3 **“Software”** is a collective term for Executable Software and Software Source Code as defined above.
- 1.4 **“Documentation”** means a copy of the documentation, as provided by IAR Systems together with the Software for use by the Licensee.
- 1.5 **“Product”** means the Software and Documentation licensed to the Licensee under the conditions of this Agreement.
- 1.6 **“Invoice”** means IAR Systems’ or IAR Distributor’s invoice to the Licensee for the Product license granted hereunder.
- 1.7 **“PC-locked License”** has the meaning set out in section 3.2.
- 1.8 **“Mobile License”** has the meaning set out in section 3.3.
- 1.9 **“Multi-user License”** has the meanings set out in section 3.4.
- 1.10 **“Network License”** has the meanings set out in section 3.5.
- 1.11 **“Global Network License”** has the meanings set out in section 3.6.
- 1.12 **“Concurrent Users”** has the meaning as set out in section 3.7.
- 1.13 **“Commuter license”** has the meaning as set out in section 3.8.
- 1.14 **“Evaluation License”** has the meanings set out in section 3.12.
- 1.15 **“Site”** means the physical premises of the Licensee within the borders of one city.
- 1.16 **“Target Architecture”** means the family or group of embedded micro-controller and micro-processor devices belonging to one processor architecture, as defined by its instruction set, and as specified on the Invoice.
- 1.17 **“Support and Update Services”** means the services set out in section 12.

## **2. TERM OF AGREEMENT**

- 2.1 This Agreement shall become effective on the latest at the Licensee’s receipt of the Software and shall remain in effect for an indefinite period in time, subject to the terms and conditions set out below – in particular the right of IAR Systems to terminate the Agreement upon Licensee’s breach. Registration of the Licensee as a rightful user of Licensed Products shall be made in accordance with applicable instructions from IAR Systems.
- 2.2 For the avoidance of doubt: Also for Software delivered with a temporary license key (for some products called quick start key) enabling use for a limited time, the Agreement terms have become effective, including but not limited to its payment terms and use restrictions, already upon the Licensee’s receipt of the Software, regardless of whether registration is made or not. (Evaluation licenses without obligation to pay license fees, are available to the extent separately provided by IAR Systems.)

## **3. OWNERSHIP AND LICENSE GRANT**

- 3.1 IAR Systems holds the copyright, trade secrets, and any other intellectual property rights which subsist in the Licensed Product and all copies thereof. No title or other rights in the Licensed Product (other than rights expressly granted herein) shall pass to the Licensee.

**THE PRODUCT IS LICENSED, NOT SOLD, TO THE LICENSEE FOR USE ONLY UNDER THE TERMS OF THIS AGREEMENT. THE LICENSEE ACKNOWLEDGES THAT THE PRODUCT CONSISTS OF PROPRIETARY, UNPUBLISHED PRODUCTS OF IAR SYSTEMS, PROTECTED UNDER INTERNATIONAL COPYRIGHT AND TRADE SECRET LAWS.**



# IAR Software License Agreement

---

**3.2 PC-locked License:** To the extent the relevant license granted is a PC-locked License, the terms in 3.2.a and 3.2.b shall apply.

A PC-locked License is a single-user license, locked to the computer where the software is installed.

3.2.a Subject to the terms and conditions of this Agreement, IAR Systems hereby grants to the Licensee a personal, non-transferable and non-exclusive PC-locked License to use the Software. The Licensee's number of authorized users of the Software under the PC-locked License, if more than one, is stated in the Invoice or otherwise in writing from IAR Systems.

3.2.b The PC-locked License may be used by the Licensee only on one single, self-contained computer unit (stationary or portable), designated through its IP number or other means of identification. A switch of the designated computer to another single computer may be allowed to transfer the license via a transfer program provided by IAR Systems within the license management system. The Software may not be accessed by users from other computer units than the unit designated as set forth in this clause; through modem, Internet or any other means of network or remote access.

**3.3 Mobile License:** To the extent the relevant license granted is a Mobile License, the terms in 3.3.a and 3.3.b shall apply.

A Mobile License comes with a hardware lock (dongle). A hardware lock is a device to be attached to one of the computer's external ports, which allows the Licensee to move the license to another computer. A hardware lock is part of the product package only to the extent explicitly ordered.

3.3.a Subject to the terms and conditions of this Agreement, IAR Systems hereby grants to the Licensee a personal, non-transferable and non-exclusive Mobile License to use the Software. The Licensee's number of authorized users of the Software under the Mobile License, if more than one, is stated in the Invoice or otherwise in writing from IAR Systems.

3.3.b The Mobile License may be used by the Licensee only for one single user, but with the right to a switch of the designated computer to another single computer using a hardware lock. The Software may not be accessed by users from other computer units than the unit designated as set forth in this clause; through modem, Internet or any other means of network or remote access.

**3.4 Multi-user License:** To the extent the Product license granted is a Multi-user License, the terms in this 3.4 shall apply.

Subject to the terms and conditions of this Agreement, IAR Systems hereby grants to the Licensee a personal, non-transferable and non-exclusive Multi-user License to use the Software. The Licensee's number of authorized users of the Software under the Multi-user License, if more than one, is stated in the Invoice or otherwise in writing from IAR Systems or IAR Distributors.

3.5 A Network License is a Multi-user License, located on a single designated license server and used by multiple users on a network and on one Site only. The Network License is locked either to the computer where the license server software runs, or to a hardware lock (dongle). The use of a hardware lock allows to move the Network License to another server computer, in case of server failure. The Network License can be used on all client computers on the network where the Software is installed. However, the Network License is made for a maximum number of concurrent users.

3.6 A **Global Network License** is a Multi-user License, located on a license server and used by multiple users on a network that can be accessed from multiple Sites globally. The Global Network License is locked either to the computer where the license server software runs, or to a hardware lock (dongle). The use of a hardware lock allows to move the Global Network License to another server computer, in case of server failure. The Global Network License can be used on all client computers on the network where the Software is installed. However, the Global Network License is made for a maximum number of concurrent users.

**3.7 Concurrent Users:** For Products that are Executable Software and licensed as Network Licenses, the definition of concurrency is given by the license server software, which also keeps track of the number of current of users. A user session of an Executable Software is always a minimum of thirty (30) minutes, and is deemed to last for additional thirty (30) minutes after the last license activation by the license server. For Products including Software Source Code, the software shall be deemed in (concurrent) use on a computer when it is loaded into temporary memory (i.e. RAM) or installed into permanent memory (e.g., hard disk, CD-ROM, or other storage device) of that computer.

**3.8 Commuter licensing:** For Products released 2012 and later including a new license management system (LMS) a commuter license is granted. Commuter licensing permits a temporary use of a network license on a personal computer not connected to the network for up to 15 days. The commuter license permits the use of the Product outside the designated Site.

**3.9 Source Code License:** If the Product Licensee receives hereunder contained software modules or components in source code format ("Software Source Code"), the following shall apply to such Software Source Code, in addition to all other provisions of this Agreement:

The Licensee may use such Software Source Code only in conjunction with the Product and the Software Source Code or any derivative works thereof. The Software Source Code may only be compiled and linked with products

# IAR Software License Agreement

---

from IAR Systems, and only in accordance with the provisions on such use set out in the Documentation and/ or this Agreement. The Licensee is strictly prohibited to make any other use of the Software Source Code. Any breach of this Section 3.9 shall be considered a material breach of this Agreement.

**THE LICENSEE ACKNOWLEDGES THAT THE SOFTWARE SOURCE CODE EMBEDS COPYRIGHTED AND PROPRIETY INFORMATION OF IAR SYSTEMS, AND THAT MAKING SOFTWARE SOURCE CODE ACCESSIBLE TO OTHERS OUTSIDE THE SCOPE OF THIS AGREEMENT, BY THE NATURE OF SOURCE CODE, SEVERELY DAMAGES THE INTELLECTUAL PROPERTY RIGHTS OF IAR SYSTEMS, AND AGREES TO COMPENSATE IAR FOR ALL DAMAGE RESULTING FROM SUCH BREACH, THAT CAN BE REASONABLY SUBSTANTIATED BY IAR. The Licensee shall keep and protect the Software Source Code with at least the same degree of care as its own proprietary source code, as further specified in section 5.**

3.10 If the Product the Licensee receives hereunder contains Third Party-Owned software, the use of such Third Party-Owned software may be restricted to a specific Target Architecture. See Section 11.2 below.

3.11 Back-up Copies: The Licensee may make back-up copies of the Software in machine executable code form, only to be used in the event and to the extent that the copy of the Software received from IAR Systems fails to function, is lost, damaged, or destroyed. The Licensee warrants that it will make no other copies of the Software and will not allow, authorize, or assist others to copy any part or all of the Software in any form without the prior written approval of IAR Systems. There may be no more copies than are necessary to form part of a reasonable back-up cycle for the Licensee. Back-up copies of the Software may be kept by the Licensee in a bank deposit or other such secure place as is normally used by the Licensee for storage of its computer program back-ups. The rights for the Licensee under this section shall not in any case include any measures to affect or decrease the function of the software protection included in the software.

3.12 An **Evaluation License** is solely intended for testing and evaluation purposes. Any other use than for testing and evaluation is prohibited. IAR Systems has no obligation to provide support or related services and no warranties. IN NO EVENT SHALL IAR SYSTEMS BE LIABLE TO THE OTHER FOR ANY DIRECT, INDIRECT, INCIDENTAL, SPECIAL, CONSEQUENTIAL, PUNITIVE OR TORT DAMAGES OF ANY NATURE OR KIND WHATSOEVER, INCLUDING BUT NOT LIMITED TO LOST PROFITS, IN CONNECTION WITH OR ARISING OUT OF THE USE OR PERFORMANCE OF SOFTWARE, SUPPORT MATERIALS, OR THE PROVISION OF SERVICES, EVEN IF THE OTHER PARTY HAS BEEN ADVISED OF THE POSSIBILITY OF SUCH DAMAGES.

Section 11 in this Software License Agreement may also apply to an Evaluation License.

## **4. LICENSE RESTRICTIONS**

4.1 The Licensee may not remove, make emulation, reverse engineer, decompile, or disassemble the Executable Software. Licensee is not allowed to derive the source or assembly code of files provided in executable or object formats. The Licensee accepts that all information gained about the Software is the valuable intellectual property of IAR Systems and as such must be treated as confidential as described under Article 5. The Licensee warrants that it will not sell, license, lease, rent, loan, lend, transmit, network, communicate, or otherwise distribute or transfer the Software in any manner to any third party whether on a permanent or temporary basis, except as explicitly stated in this Agreement. Furthermore the Licensee warrants that it will not use or permit the use of (including without limitation by time sharing or network use) the Software for the benefit of any entity other than the Licensee; or in a computer service business; make unauthorized copies of the documentation; make verbal or media translations of the documentation; make telecommunications data transmissions of the Software; use long-haul gateways on any central processing unit on which the Software is used. The Licensee is also expressly prohibited from adapting, modifying, revising, improving, upgrading, enhancing, and creating derivative works of the Executable Software for any purpose including error correction or any other type of maintenance.

4.2 The Licensee shall keep records of the Licensee's use of Software. The Licensee shall make the records available to either IAR Systems or a neutral third party on reasonable notice, as agreed between the parties. In the case of a neutral third party audit, IAR Systems and Licensee shall in good faith mutually appoint an auditor. Should such an agreement not be reached within 60 days after IAR Systems notice, then the parties agree to have Business Software Alliance conduct such an audit, or itself elect an auditor. The Licensee will permit IAR Systems or a third party, as the case may be, to have access to the Licensee's records and computer systems and to use software audit tools on the Licensee's systems to ensure that the Licensee is using its software in accordance with the applicable license terms. Upon the Licensee's request, the party conducting the audit with the Licensee shall enter into a non-disclosure agreement with the Licensee, to protect the Licensee's propriety and/or confidential information. Information retrieved and/or conveyed to IAR Systems as a result of such an audit as here described shall be limited as to only ensure that the Licensee is using its software in accordance with the applicable license terms, or evidence of the contrary.

4.3 Subject to the other terms herein, and with the Licensee as fully responsible for all actions or omissions of such a consultant, Licensee may let a consultant use the Software for work solely on behalf of the Licensee for the licensed purpose and provided that the Software is not used for any other purpose or third party.

4.4 Upon each and every breach by the Licensee hereunder a contractual penalty amounting to 200% for breach



# IAR Software License Agreement

---

under sections 3.2, 3.3, 3.4, 3.5, 3.6, 3.11, 4.1 or 4.3 and 1000% for breach under section 3.8 of the applicable licensee fee under the relevant Invoice is payable by the Licensee to IAR Systems. In case IAR Systems' actual damage due to the breach would exceed this amount, also the remainder shall be paid by the Licensee, see also Section 3.8.

## **5. CONFIDENTIALITY**

5.1 The Licensee agrees that all material and information relating to the Software is made available for the use solely under and in accordance with this Agreement. The Licensee has no right at any time during or after cancellation or termination of this Agreement to disclose such material and/or information relating to the Software, whether directly or indirectly, to any third party without IAR Systems' prior written approval. The Licensee shall hold harmless, defend, and indemnify IAR Systems from and against any and all losses, costs, damages, and expenses arising out of or in connection with the Licensee's failure to comply with requirements of this Article 5. The Licensee's confidentiality obligations hereunder shall survive cancellation or termination, for any reason, of this Agreement.

## **6. PAYMENT TERMS AND CONDITIONS**

6.1 In consideration of the rights granted and services rendered by IAR Systems under this Agreement, the Licensee shall pay the license fees for the Software as specified in the Invoice. Payments are to be made according to the payment schedule stated in the Invoice, or if not stated, invoices are payable within 30 days of the invoice date.

6.2 If the Licensee fails to effect payment within the stipulated time, IAR Systems or IAR Distributors shall be entitled to a) charge interest after due date as stated in the Invoice, or if not stated in the invoice, the interest charged will be the reference rate set by Sweden's central bank (the Riksbank) + 8%. b) postpone the fulfillment of any of its own obligations until payment is made, and/or c) terminate the Agreement by notice in writing to the Licensee and recover from the Licensee any and all loss incurred.

6.3 All prices are exclusive of, and the Licensee is responsible for, all fees and taxes, including custom duties, importation fees, sales, use, withholding, gross revenue, and like taxes, dues, and charges assessed or incurred in connection with the provision of goods and services under this Agreement.

## **7. LIMITED WARRANTY**

7.1 IAR Systems warrants that the media on which the Software is recorded upon receipt by the Licensee will be free from defects in materials and faulty workmanship under normal use for a period of ninety (90) days from the date of delivery to the Licensee. During this warranty period IAR Systems will, at its option, after its receipt of the media in return, repair or replace, free of charge, defective media upon which the Software was supplied and record a copy of the Software on the repaired or replacement media. Said repair or replacement shall be the Licensee's exclusive remedy under this media warranty. Notwithstanding the foregoing, IAR Systems shall have no responsibility to repair or replace a media which, in IAR Systems' opinion, has been damaged by the Licensee by accident, abuse, or as a result of attempted self-maintenance service.

7.2 IAR Systems does not warrant that the Software will meet the Licensee's requirements or that the operation of the Software will be uninterrupted and error free. The Licensee is solely responsible for the selection of the Software to achieve its intended results or for the results actually obtained.

7.3 The above warranty does not apply to conditions resulting from improper use, external causes, including service or modifications not performed by IAR Systems or a contractor appointed by IAR Systems, or operation outside the specified environmental parameters. IAR Systems will not be responsible for operation of the Software other than on the host equipment specified in the Invoice and in conjunction with the operating environment designated for each version of the Software. Minor deviations from the above warranty, which are of little importance for the intended use of the Software and which do not cause more than minor inconvenience for the Licensee shall not be considered as breaches of the above warranty.

**7.4 THE ABOVE WARRANTY IS IAR SYSTEMS' ONLY WARRANTY WITH REGARD TO THE SOFTWARE AND THIS AGREEMENT AND, SAVE AS PROVIDED IN THIS AGREEMENT, NO OTHER WARRANTY OR CONDITION, EXPRESSED OR IMPLIED, WILL APPLY, AND THE LICENSEE WILL NOT RAISE ANY OTHER CLAIMS BASED ON THE PERFORMANCE OR LACK OF PERFORMANCE OF THE SOFTWARE. IAR SYSTEMS SPECIFICALLY EXCLUDES ALL OTHER WARRANTIES, REPRESENTATIONS OR UNDERTAKINGS, EXPRESS, IMPLIED OR STATUTORY, INCLUDING BUT NOT LIMITED TO ANY IMPLIED WARRANTIES OF MERCHANTABILITY OR FITNESS FOR A PARTICULAR PURPOSE, ABILITY TO ACHIEVE A PARTICULAR RESULT, OR OF ANY OTHER WARRANTY OBLIGATION ON THE PART OF IAR SYSTEMS.**

7.5 IAR Systems expressly disclaims any liability for any hardware or software solutions at the Licensee which may affect the performance of the Software, including but not limited to network configurations.

7.6 The provisions of this Article 7 shall survive any expiration or termination of this Agreement.

## **8. INTELLECTUAL PROPERTY INFRINGEMENT**

8.1 IAR Systems will in the way set out in 8.2, and subject to all limitations therein, act on any action brought against the Licensee to the extent it is based on a claim that the Software as it exists on the date of the Invoice infringes any patent or copyright duly issued under the laws of the country under which IAR Systems or the

# IAR Software License Agreement

---

Licensee is organized.

8.2 IAR Systems shall, in the way set out below, as sole remedy, act on a third-party claim that the Software infringes the intellectual property rights of such party, provided that IAR Systems is given prompt notice of such claim and is given information, reasonable assistance, and sole authority to defend or settle the claim. IAR Systems may at its option obtain the right for the Licensee to continue using the infringing IAR Product, replace or modify the infringing Product until it becomes non-infringing, or if such replacement or modification is not reasonably available, terminate this license with respect to the infringing Product and provide for a reasonable refund of fees paid by the Licensee to IAR Systems for the IAR Product so affected.

8.3 IAR Systems shall not have any liability if the alleged infringement arises out of unauthorized use of the Software, postdelivery, non-IAR Systems modifications, or the combination with other products or devices not furnished by IAR Systems. **THE OBLIGATIONS STATED IN THIS SECTION ARE IAR SYSTEMS' SOLE LIABILITIES AND THE LICENSEE'S SOLE REMEDIES FOR INFRINGEMENT OF PATENTS AND COPYRIGHTS. FOR THE AVOIDANCE OF DOUBT: THE LIABILITY OF IAR SYSTEMS UNDER THIS SECTION 8 MAY NEVER EXCEED THE LICENSE FEE PAID BY THE LICENSEE.**

## 9. FORCE MAJEURE

9.1 Either party shall be excused from fulfillment of any obligation under this Agreement only to the extent that and for so long as such performance is prevented or delayed by an industrial dispute or any other cause beyond its reasonable control, such as, but not limited to, riots; floods; war; warlike hostilities; fires; embargo; shortage of labor, power, fuel, means of transportation, or common lack of other necessities. A party wishing to claim relief under this Article shall forthwith notify the other party in writing on the intervention and on the cessation of such circumstance.

## 10. LIMITATION OF LIABILITY

10.1 THE USE OF THE SOFTWARE AND ALL CONSEQUENCES ARISING THEREFROM IS THE SOLE RESPONSIBILITY OF LICENSEE. IAR SYSTEMS SHALL NOT BE LIABLE TO THE LICENSEE FOR ANY LOSS OR DAMAGE CAUSED ARISING DIRECTLY OR INDIRECTLY IN CONNECTION WITH THE SOFTWARE, THE USE OF THE SOFTWARE, OR OTHERWISE.

10.2 IAR SYSTEMS' LIABILITY VIS-À-VIS THE LICENSEE UNDER THIS AGREEMENT SHALL UNDER ALL CIRCUMSTANCES BE LIMITED TO FIFTY (50) PER CENT OF THE LICENSE FEE FOR THE SOFTWARE PAID BY THE LICENSEE HEREUNDER, PROVIDED HOWEVER THAT IF SECTION 8 IS APPLICABLE THE TOTAL LIABILITY OF IAR SYSTEMS HEREUNDER MAY INSTEAD NEVER EXCEED 100% OF THE LICENSE FEE PAID BY THE LICENSEE HEREUNDER FOR SUCH SOFTWARE.

10.3 IAR SYSTEMS SHALL IN NO EVENT BE LIABLE TO THE LICENSEE UNDER THIS AGREEMENT FOR ANY SPECIAL, INDIRECT, INCIDENTAL, OR CONSEQUENTIAL DAMAGES UNDER ANY LEGAL THEORY, SUCH AS LOSS OF DATA, USE AND/OR PROFITS, BUSINESS INTERRUPTION OR DOWNTIME COSTS AND CAPITAL COSTS OR CLAIM OF THIRD PARTY, WHETHER ON ACCOUNT OF DEFECTS, PERFORMANCES, NON-PERFORMANCES, DELAYS, PERSONAL INJURIES, PROPERTY DAMAGES, OR OTHERWISE, REGARDLESS WHETHER IAR SYSTEMS HAS BEEN ADVISED OF THE POSSIBILITY OF SUCH DAMAGES.

10.4 NOTHING IN THIS AGREEMENT SHALL EXCLUDE OR LIMIT THE LIABILITY UNDER APPLICABLE COMPULSORY LAW OF IAR SYSTEMS FOR DEATH OR PERSONAL INJURY RESULTING FROM ITS NEGLIGENCE.

10.5 The provisions of this Article 10 shall survive the cancellation or termination of this Agreement.

## 11. THIRD PARTY RIGHTS

11.1 The IAR Embedded Workbench for Eclipse includes Eclipse Materials. This License does not apply to such Eclipse Material and this is not included in the term "Software" under this License. You agree to comply with all terms and conditions imposed on you in respect of such Eclipse Materials.

11.1.1 The Eclipse Materials are licensed under the terms of the Eclipse Public License (EPL), Version 1.0, a copy of which is included in the Eclipse Materials and also available.

11.2 The IAR Embedded Workbench may include Third Party-Owned software. In addition to all other provisions of this License the Third Party-Owned software shall also be subject to the supplemental terms and conditions governing such Third Party-Owned software. These supplemental terms add to the terms of this License and shall supersede any inconsistent or conflicting terms in this License as they pertain to the Third Party-Owned software. If the Product the Licensee receives hereunder contains Third Party-Owned software the Licensee agree to comply with all terms and conditions imposed on you in respect of such Third Party-Owned software.

11.2.1 The Third Party-Owned Software is subject to the additional terms of each Third Party and a copy of these supplemental terms is available.

## 12. SUPPORT AND UPDATE AGREEMENT (SUA)

12.1 Excluding what is specified in Section 12.2 and/or Section 7 of this Agreement, this Agreement does not grant the Licensee any right whatsoever to any improvements, modifications, enhancements or updates to the Software, or any other support services relating to the Software.

12.2 To the extent that the license granted includes a time-limited Support and Update Service, the Licensee

# IAR Software License Agreement

---

will be entitled to the services defined in the Support and Update Agreement (“SUA”) attached hereto. In the case that the license granted does not include Support and Update Services or in the case where such services have expired, the Licensee may, depending on the nature of the granted license, purchase additional periods of Support and Update Services

12.3 Use of improvements, modifications, enhancements or updates received by the Licensee under IAR Systems’ Support and Update Agreement (SUA) or received under Section 7 of this Agreement, shall be governed by the terms and conditions contained herein.

## **13. TERMINATION OF THE AGREEMENT**

13.1 IAR Systems shall have the right to terminate this Agreement with immediate effect if the Licensee is in breach of any of its obligations under this Agreement, including, but not limited to (a) use of the Software in any manner other than pursuant to the rights granted in Article 3 and 4, (b) breach of the confidentiality provisions of Article 5, or (c) failure of the Licensee to remit payments as provided in Article 6.

13.2 This Agreement will terminate immediately without notice if Licensee suspends its payments, becomes bankrupt or insolvent or enters into liquidation or otherwise can be regarded as insolvent.

13.3 Upon IAR Systems’ termination of this Agreement, as set out in this Article, then, IAR Systems may, at its option, and in addition to any other rights hereunder, and in addition to any other remedies available to IAR Systems under the law, in writing require the Licensee to return or destroy all versions of the Software and the Documentation and any and all documentation relating thereto on any media and in any form in Licensee’s possession. Licensee shall give a written confirmation to IAR Systems that all material related to the Software and its operation has been returned to IAR Systems or destroyed. The provisions of this Section 13.3 shall survive the cancellation or termination of this Agreement.

## **14. EXPORT CONTROL REGULATIONS**

14.1 The Software and the Documentation is subject to export or import regulations in various countries, including the regulations of the United States Export Administration Act. The Licensee hereby agrees that the Licensee will not knowingly (a) export or reexport, directly or indirectly, any product or technical data or any controlled products restricted by applicable national regulations, including software, received from IAR Systems under this agreement, (b) disclose such technical data for use in, or (c) export or reexport, directly or indirectly, any direct product of such technical data or of such other controlled products, including software, to any destination to which such export or reexport is restricted or prohibited by U.S. or applicable non-U.S. law, without obtaining prior written consent of IAR Systems.

## **15. MISCELLANEOUS**

15.1 This Agreement shall not in any situation be assignable or transferable in whole or in part by either party, without the prior written approval of the other party. This notwithstanding, IAR Systems shall be entitled to assign this Agreement in whole or in part to a company within the IAR Systems Group, and IAR Systems may assign this Agreement without penalty or detriment to its rights under this Agreement, and without the Licensee’s prior written consent, in the event of a merger or similar reorganization or sale of substantially all of IAR Systems’ assets.

15.2 No alteration or amendment to this Agreement shall be valid unless such alteration or amendment is made in writing and signed by the parties hereto.

15.3 Any notice or other communication under this Agreement shall be made in writing either by hand or by telefax (confirmed by airmail) or by certified or registered airmail first-class postage prepaid to the parties at the addresses stated in the Invoice (or at such other address a party may specify by written notice to the other).

15.4 This Agreement contains the entire understanding between the parties on its subject matter, and annuls and replaces any other agreements or understandings, whether written or oral, which may exist or have existed between the parties on the subject matter hereof.

15.5 This Agreement shall be governed by and construed in accordance with the substantive to the courts of the country in which IAR Systems is incorporated. Any dispute concerning this agreement or the interpretation or validity thereof, or any other dispute based thereon, shall be submitted to the courts of the country in which IAR Systems is incorporated.

15.6 The provisions of this Article 15 shall survive the cancellation or termination of this Agreement.

This document contains Third Party Software Notices and/or Additional Terms and Conditions for licensed third party software components included within IAR Systems software product **IAR Embedded Workbench**. These notices and/or additional terms and conditions are made a part of and incorporated by reference into the IAR Software License Agreement.

# IAR Software License Agreement

## 1. Components used internally in IAR Embedded Workbench

<b>Third Party Software</b>	Notice/Terms
<b>SCINTILLA</b>	<p>License for Scintilla and SciTE            Copyright 1998-2002 by Neil Hodgson. All Rights Reserved.            Permission to use, copy, modify, and distribute this software and its documentation for any purpose and without fee is hereby granted, provided that the above copyright notice appear in all copies and that both that copyright notice and this permission notice appear in supporting documentation.</p> <p>NEIL HODGSON DISCLAIMS ALL WARRANTIES WITH REGARD TO THIS SOFTWARE, INCLUDING ALL IMPLIED WARRANTIES OF MERCHANTABILITY AND FITNESS, IN NO EVENT SHALL NEIL HODGSON BE LIABLE FOR ANY SPECIAL, INDIRECT OR CONSEQUENTIAL DAMAGES OR ANY DAMAGES WHATSOEVER RESULTING FROM LOSS OF USE, DATA OR PROFITS, WHETHER IN AN ACTION OF CONTRACT, NEGLIGENCE OR OTHER TORTIOUS ACTION, ARISING OUT OF OR IN CONNECTION WITH THE USE OR PERFORMANCE OF THIS SOFTWARE</p>
<b>IBM ICU</b>	<p>ICU License - ICU 1.8.1 and later COPYRIGHT AND PERMISSION NOTICE            Copyright (c) 1995-2003 International Business Machines Corporation and others            All rights reserved.</p> <p>Permission is hereby granted, free of charge, to any person obtaining a copy of this software and associated documentation files (the "Software"), to deal in the Software without restriction, including without limitation the rights to use, copy, modify, merge, publish, distribute, and/or sell copies of the Software, and to permit persons to whom the Software is furnished to do so, provided that the above copyright notice(s) and this permission notice appear in all copies of the Software and that both the above copyright notice(s) and this permission notice appear in supporting documentation.</p> <p>THE SOFTWARE IS PROVIDED "AS IS", WITHOUT WARRANTY OF ANY KIND, EXPRESS OR IMPLIED, INCLUDING BUT NOT LIMITED TO THE WARRANTIES OF MERCHANTABILITY, FITNESS FOR A PARTICULAR PURPOSE AND NONINFRINGEMENT OF THIRD PARTY RIGHTS. IN NO EVENT SHALL THE COPYRIGHT HOLDER OR HOLDERS INCLUDED IN THIS NOTICE BE LIABLE FOR ANY CLAIM, OR ANY SPECIAL INDIRECT OR CONSEQUENTIAL DAMAGES, OR ANY DAMAGES WHATSOEVER RESULTING FROM LOSS OF USE, DATA OR PROFITS, WHETHER IN AN ACTION OF CONTRACT, NEGLIGENCE OR OTHER TORTIOUS ACTION, ARISING OUT OF OR IN CONNECTION WITH THE USE OR PERFORMANCE OF THIS SOFTWARE.</p> <p>Except as contained in this notice, the name of a copyright holder shall not be used in advertising or otherwise to promote the sale, use or other dealings in this Software without prior written authorization of the copyright holder. All trademarks and registered trademarks mentioned herein are the property of their respective owners</p>

# IAR Software License Agreement

<p><b>Apache</b></p>	<p>The Apache Software License, Version 1.1          Copyright (c) 1999-2003 The Apache Software Foundation. All rights reserved.          Redistribution and use in source and binary forms, with or without modification, are permitted provided that the following conditions are met:</p> <ol style="list-style-type: none"> <li>1. Redistributions of source code must retain the above copyright notice, this list of conditions and the following disclaimer.</li> <li>2. Redistributions in binary form must reproduce the above copyright notice, this list of conditions and the following disclaimer in the documentation and/or other materials provided with the distribution.</li> <li>3. The end-user documentation included with the redistribution, if any, must include the following acknowledgment: "This product includes software developed by the Apache Software Foundation." Alternately, this acknowledgment may appear in the software itself, if and wherever such third-party acknowledgments normally appear.</li> <li>4. The names "Xerces" and "Apache Software Foundation" must not be used to endorse or promote products derived from this software without prior written permission.</li> <li>5. Products derived from this software may not be called "Apache", nor may "Apache" appear in their name, without prior written permission of the Apache Software Foundation.</li> </ol> <p>THIS SOFTWARE IS PROVIDED `AS IS` AND ANY EXPRESSED OR IMPLIED WARRANTIES, INCLUDING, BUT NOT LIMITED TO, THE IMPLIED WARRANTIES OF MERCHANTABILITY AND FITNESS FOR A PARTICULAR PURPOSE ARE DISCLAIMED. IN NO EVENT SHALL THE APACHE SOFTWARE FOUNDATION OR ITS CONTRIBUTORS BE LIABLE FOR ANY DIRECT, INDIRECT, INCIDENTAL, SPECIAL, EXEMPLARY, OR CONSEQUENTIAL DAMAGES (INCLUDING, BUT NOT LIMITED TO, PROCUREMENT OF SUBSTITUTE GOODS OR SERVICES; LOSS OF USE, DATA, OR PROFITS; OR BUSINESS INTERRUPTION) HOWEVER CAUSED AND ON ANY THEORY OF LIABILITY, WHETHER IN CONTRACT, STRICT LIABILITY, OR TORT (INCLUDING NEGLIGENCE OR OTHERWISE) ARISING IN ANY WAY OUT OF THE USE OF THIS SOFTWARE, EVEN IF ADVISED OF THE POSSIBILITY OF SUCH DAMAGE.</p> <p>This software consists of voluntary contributions made by many individuals on behalf of the Apache Software Foundation and was originally based on software copyright (c) 1999, International Business Machines.</p>
<p><b>LLVM</b></p>	<p>LLVM Release License          University of Illinois/NCSA. Open Source License.          Copyright (c) 2003-2011 University of Illinois at Urbana-Champaign. All rights reserved.          Developed by: LLVM Team University of Illinois at Urbana-Champaign. Permission is hereby granted, free of charge, to any person obtaining a copy of this software and associated documentation files (the "Software"), to deal with the Software without restriction, including without limitation the rights to use, copy, modify, merge, publish, distribute, sublicense, and/or sell copies of the Software, and to permit persons to whom the Software is furnished to do so, subject to the following conditions:</p> <p>* Redistributions of source code must retain the above copyright notice, this list of conditions and the following disclaimers. * Redistributions in binary form must reproduce the above copyright notice, this list of conditions and the following disclaimers in the documentation and/or other materials provided with the distribution. * Neither the names of the LLVM Team, University of Illinois at Urbana-Champaign, nor the names of its contributors may be used to endorse or promote products derived from this Software without specific prior written permission.</p> <p>THE SOFTWARE IS PROVIDED "AS IS", WITHOUT WARRANTY OF ANY KIND, EXPRESS OR IMPLIED, INCLUDING BUT NOT LIMITED TO THE WARRANTIES OF MERCHANTABILITY, FITNESS FOR A PARTICULAR PURPOSE AND NONINFRINGEMENT. IN NO EVENT SHALL THE CONTRIBUTORS OR COPYRIGHT HOLDERS BE LIABLE FOR ANY CLAIM, DAMAGES OR OTHER LIABILITY, WHETHER IN AN ACTION OF CONTRACT, TORT OR OTHERWISE, ARISING FROM, OUT OF OR IN CONNECTION WITH THE SOFTWARE OR THE USE OR OTHER DEALINGS WITH THE SOFTWARE..</p>



# IAR Software License Agreement

<p><b>Boost C++ Libraries</b></p>	<p>Boost Software License - Version 1.0 - August 17th, 2003            Permission is hereby granted, free of charge, to any person or organization obtaining a copy of the software and accompanying documentation covered by this license (the “Software”) to use, reproduce, display, distribute, execute, and transmit the Software, and to prepare derivative works of the Software, and to permit third-parties to whom the Software is furnished to do so, all subject to the following: The copyright notices in the Software and this entire statement, including the above license grant, this restriction and the following disclaimer, must be included in all copies of the Software, in whole or in part, and all derivative works of the Software, unless such copies or derivative works are solely in the form of machine-executable object code generated by a source language processor.            THE SOFTWARE IS PROVIDED “AS IS”, WITHOUT WARRANTY OF ANY KIND, EXPRESS OR IMPLIED, INCLUDING BUT NOT LIMITED TO THE WARRANTIES OF MERCHANTABILITY, FITNESS FOR A PARTICULAR PURPOSE, TITLE AND NON-INFRINGEMENT. IN NO EVENT SHALL THE COPYRIGHT HOLDERS OR ANYONE DISTRIBUTING THE SOFTWARE BE LIABLE FOR ANY DAMAGES OR OTHER LIABILITY, WHETHER IN CONTRACT, TORT OR OTHERWISE, ARISING FROM, OUT OF OR IN CONNECTION WITH THE SOFTWARE OR THE USE OR OTHER DEALINGS IN THE SOFTWARE.</p>
<p><b>Protocol Buffers</b></p>	<p>Protocol Buffers - Google’s data interchange format            Copyright 2008 Google Inc. All rights reserved. Redistribution and use in source and binary forms, with or without modification, are permitted provided that the following conditions are met:            * Redistributions of source code must retain the above copyright notice, this list of conditions and the following disclaimer. * Redistributions in binary form must reproduce the above copyright notice, this list of conditions and the following disclaimer in the documentation and/or other materials provided with the distribution. * Neither the name of Google Inc. nor the names of its contributors may be used to endorse or promote products derived from this software without specific prior written permission.            THIS SOFTWARE IS PROVIDED BY THE COPYRIGHT HOLDERS AND CONTRIBUTORS “AS IS” AND ANY EXPRESS OR IMPLIED WARRANTIES, INCLUDING, BUT NOT LIMITED TO, THE IMPLIED WARRANTIES OF MERCHANTABILITY AND FITNESS FOR A PARTICULAR PURPOSE ARE DISCLAIMED. IN NO EVENT SHALL THE COPYRIGHT OWNER OR CONTRIBUTORS BE LIABLE FOR ANY DIRECT, INDIRECT, INCIDENTAL, SPECIAL, EXEMPLARY, OR CONSEQUENTIAL DAMAGES (INCLUDING, BUT NOT LIMITED TO, PROCUREMENT OF SUBSTITUTE GOODS OR SERVICES; LOSS OF USE, DATA, OR PROFITS; OR BUSINESS INTERRUPTION) HOWEVER CAUSED AND ON ANY THEORY OF LIABILITY, WHETHER IN CONTRACT, STRICT LIABILITY, OR TORT (INCLUDING NEGLIGENCE OR OTHERWISE) ARISING IN ANY WAY OUT OF THE USE OF THIS SOFTWARE, EVEN IF ADVISED OF THE POSSIBILITY OF SUCH DAMAGE.</p>

## 2. Components potentially used in customer applications

<p><b>Third Party Software</b></p>	<p>Notice/Terms</p>
<p><b>dmalloc</b></p>	<p>Version of malloc/free/realloc (aka dmalloc) written by Doug Lea and released to the public domain, as explained.</p>

# IAR Software License Agreement

<b>Dinkum C++ Library</b>	<p>Dinkum Abridged/C Library Sub license</p> <p>Definition: The term “Licensed Source” shall mean the Dinkum Abridged Library source code, the Dinkum C Library source code and the Dinkum Abridged Library Reference, or a later version of the same products. A Sub license is granted solely in conjunction with, and for use with IAR C/EC++/ C++ Cross Compiler owned by IAR Systems AB. The Sub Licensee shall supply to Dinkumware Ltd (“Licensor”) with the following protections:</p> <p>(a)Plauger’s ownership. a.Sub Licensee acknowledges and agrees that: *Title and all rights of ownership to the Licensed Source, and all copies of all or any part thereof, are and remain with Plauger; *Sub Licensee shall not lend, sell, lease, hypothecate or otherwise dispose of the Licensed Source. *All copies of the Licensed Source, or any part thereof, in any form whatsoever, including but not limited to, forms cognizable to the human eye (directly, or upon enlargement or translation), or to data processing or other equipment, shall be the sole and exclusive property of Plauger, as described immediately above; and *Licensor has represented that the Licensed Source may contain Licensor’s trade secrets and proprietary information, whether or not any portion thereof is or may be copyrighted or patented. b.Sub Licensee agrees to preserve unchanged all copyright notices in all copies of the Licensed Source. c.Licensor acknowledges and agrees that Sub Licensee shall have no obligation to deliver or disclose to Licensor any modifications that Sub Licensee makes to the Licensed Source, ant that Sub Licensee shall own and have exclusive marketing rights to any such undisclosed modifications. d.Sub Licensee acknowledges and agrees that any modifications that Sub Licensee makes to the Licensed Source and discloses to Licensor, unless otherwise indicated in writing by Sub Licensee on or before disclosure (“Disclosed Modifications”), shall become the property of Plauger. Disclosed Modifications to the Licensed Library Source shall become the property of Plauger. Sub Licensee hereby assigns to Plauger all of Sub Licensee’s right, title, and interest in and to such Disclosed Modifications and in and to the copyrights and all other rights in the Disclosed Modifications. (b) License. a.Licensor hereby grants to Sub Licensee a personal, non-exclusive, and non-transferable license to use or modify the Licensed Source for its own internal business purposes solely in conjunction with IAR C/EC++/C++ Cross Compiler owned by IAR Systems. b.Notwithstanding the foregoing, Sub Licensee may make only such copies of the Licensed Source as are reasonably necessary for it to exercise its right hereunder. Sub Licensee acknowledges that it may not sell, assign, sublicense, lease or otherwise transfer, or permit others to use or execute the Licensed Source, or any port thereof, or any modification or improvement of the Licensed Source, or any object code which is derived from the Licensed Source. c.Sub Licensee agrees to comply with all applicable laws, regulations, rulings, and executive order from the United States relating to the export or re-export of the Licensed Source, and with all applicable foreign laws which must be complied with in order to protect or preserve Licensor’s copyright(s), trade secret(s), and other proprietary rights in and to the Licensed Source. Sub Licensee agrees that it will not knowingly ship or divert the Licensed Source for use in any country which has ratified neither the Berne Copyright Convention nor the Universal Copyright Convention without first obtaining written permission from Licensor. (c)Warranty and Disclaimer of Warranty. a.Licensor warrants that, at the time of delivery, the Licensed Source will be in good operating condition and will be Standard Conforming in all essential respects. b.Licensor represents and warrants that it is not aware that the Licensed Source is created in whole or in part by violation of the protected trade secret of another or that the Licensed Source infringes any U.S. patent or copyright.</p> <p>c.THE FOREGOING LIMITED WARRANTIES ARE THE ONLY WARRANTIES OF LICENSOR TO SUB LICENSEE AND ARE IN LIEU OF ALL OTHER WARRANTIES, EXPRESS OR IMPLIED, INCLUDING, BUT NOT LIMITED TO, THE IMPLIED WARRANTIES OF MERCHANTABILITY AND FITNESS FOR A PARTICULAR PURPOSE.</p> <p>(d)Limitation of Liability. a.In no event shall Licensor be liable to Sub Licensee for any lost profits, incidental, special, exemplary, punitive, indirect or other consequential dam ages, even if Licensor knows or has been advised of the possibility of such damages, or for any claim against Sub Licensee by any other person or entity, or for any damage caused by Sub Licensee’s failure to perform its responsibilities.</p>
-------------------------------	---

# Freescale MQX RTOS 4.0.2

---

**IMPORTANT.** Read the following Freescale Semiconductor Software License Agreement (“Agreement”) completely. By selecting the “I Accept” button below, you indicate that you accept the terms of this Agreement. You may then install the software.

## **FREESCALE SEMICONDUCTOR SOFTWARE LICENSE AGREEMENT**

This is a legal agreement between you (either as an individual or as an authorized representative of your employer) and Freescale Semiconductor, Inc. (“Freescale”). It concerns your rights to use this file and any accompanying written materials (the “Software”). In consideration for Freescale allowing you to access the Software, you are agreeing to be bound by the terms of this Agreement. If you do not agree to all of the terms of this Agreement, do not download the Software. If you change your mind later, stop using the Software and delete all copies of the Software in your possession or control. Any copies of the Software that you have already distributed, where permitted, and do not destroy will continue to be governed by this Agreement. Your prior use will also continue to be governed by this Agreement.

**LICENSE GRANT.** Exclusively in conjunction with Licensee’s development and sale of a product containing a programmable processing unit (e.g., a microprocessor, microcontroller, or digital signal processor) supplied directly or indirectly from Freescale (“Freescale System”) and listed under “By Products” on the Freescale MQX website, Freescale grants to you, free of charge, the non-exclusive, non-transferable right (1) to use the Software, (2) to reproduce the Software, (3) to prepare derivative works of the Software, (4) to distribute the Software and derivative works thereof in object (machine-readable) form as part of a Freescale System, and (5) to sublicense to others the right to use the distributed Software as included within the Freescale System. You must prohibit your sublicensees from translating, reverse engineering, decompiling, or disassembling the Software except to the extent applicable law specifically prohibits such restriction. If you violate any of the terms or restrictions of this Agreement, Freescale may immediately terminate this Agreement, and require that you stop using and delete all copies of the Software in your possession or control.

**COPYRIGHT.** The Software is licensed to you, not sold. Freescale owns the Software, and United States copyright laws and international treaty provisions protect the Software. Therefore, you must treat the Software like any other copyrighted material (e.g. a book or musical recording). You may not use or copy the Software for any other purpose than what is described in this Agreement. Except as expressly provided herein, Freescale does not grant to you any express or implied rights under any Freescale or third-party patents, copyrights, trademarks, or trade secrets. Additionally, you must reproduce and apply any copyright or other proprietary rights notices included on or embedded in the Software to any copies or derivative works made thereof, in whole or in part, if any.

**SUPPORT.** Freescale is NOT obligated to provide any support, upgrades or new releases of the Software. If you wish, you may contact Freescale and report problems and provide suggestions regarding the Software. Freescale has no obligation whatsoever to respond in any way to such a problem report or suggestion. Freescale may make changes to the Software at any time, without any obligation to notify or provide updated versions of the Software to you.

**NO WARRANTY. TO THE MAXIMUM EXTENT PERMITTED BY LAW, FREESCALE EXPRESSLY DISCLAIMS ANY WARRANTY FOR THE SOFTWARE. THE SOFTWARE IS PROVIDED “AS IS”, WITHOUT WARRANTY OF ANY KIND, EITHER EXPRESS OR IMPLIED, INCLUDING, WITHOUT LIMITATION, THE IMPLIED WARRANTIES OF MERCHANTABILITY, FITNESS FOR A PARTICULAR PURPOSE, OR NON-INFRINGEMENT. YOU ASSUME THE ENTIRE RISK ARISING OUT OF THE USE OR PERFORMANCE OF THE SOFTWARE, OR ANY SYSTEMS YOU DESIGN USING THE SOFTWARE (IF ANY). NOTHING IN THIS AGREEMENT MAY BE CONSTRUED AS A WARRANTY OR REPRESENTATION BY FREESCALE THAT THE SOFTWARE OR ANY DERIVATIVE WORK DEVELOPED WITH OR INCORPORATING THE SOFTWARE WILL BE FREE FROM INFRINGEMENT OF THE INTELLECTUAL PROPERTY RIGHTS OF THIRD PARTIES.**

**INDEMNITY.** You agree to fully defend and indemnify Freescale from any and all claims, liabilities, and costs (including reasonable attorney’s fees) related to (1) your use (including your sublicensee’s use, if permitted) of the Software or (2) your violation of the terms and conditions of this Agreement.

**LIMITATION OF LIABILITY. IN NO EVENT WILL FREESCALE BE LIABLE, WHETHER IN CONTRACT, TORT, OR OTHERWISE, FOR ANY INCIDENTAL, SPECIAL, INDIRECT, CONSEQUENTIAL OR PUNITIVE DAMAGES, INCLUDING, BUT NOT LIMITED TO, DAMAGES FOR ANY LOSS OF USE, LOSS OF TIME, INCONVENIENCE, COMMERCIAL LOSS, OR LOST PROFITS, SAVINGS, OR REVENUES TO THE FULL EXTENT SUCH MAY BE DISCLAIMED BY LAW.**

**COMPLIANCE WITH LAWS; EXPORT RESTRICTIONS.** You must use the Software in accordance with all



# Freescale MQX RTOS 4.0.2

---

applicable U.S. laws, regulations and statutes. You agree that neither you nor your licensees (if any) intend to or will, directly or indirectly, export or transmit the Software to any country in violation of U.S. export restrictions.

**GOVERNMENT USE.** Use of the Software and any corresponding documentation, if any, is provided with RESTRICTED RIGHTS. Use, duplication or disclosure by the Government is subject to restrictions as set forth in subparagraph (c)(1)(ii) of The Rights in Technical Data and Computer Software clause at DFARS 252.227-7013 or subparagraphs (c)(1) and (2) of the Commercial Computer Software – Restricted Rights at 48 CFR 52.227-19, as applicable. Manufacturer is Freescale Semiconductor, Inc.

**HIGH RISK ACTIVITIES.** You acknowledge that the Software is not fault tolerant and is not designed, manufactured or intended by Freescale for incorporation into products intended for use or resale in on-line control equipment in hazardous, dangerous to life or potentially life-threatening environments requiring fail-safe performance, such as in the operation of nuclear facilities, aircraft navigation or communication systems, air traffic control, direct life support machines or weapons systems, in which the failure of products could lead directly to death, personal injury or severe physical or environmental damage (“High Risk Activities”). You specifically represent and warrant that you will not use the Software or any derivative work of the Software for High Risk Activities.

**CHOICE OF LAW; VENUE; LIMITATIONS.** You agree that the statutes and laws of the United States and the State of Texas, USA, without regard to conflicts of laws principles, will apply to all matters relating to this Agreement or the Software, and you agree that any litigation will be subject to the exclusive jurisdiction of the state or federal courts in Texas, USA. You agree that regardless of any statute or law to the contrary, any claim or cause of action arising out of or related to this Agreement or the Software must be filed within one (1) year after such claim or cause of action arose or be forever barred.

**PRODUCT LABELING.** You are not authorized to use any Freescale trademarks, brand names, or logos.

**ENTIRE AGREEMENT.** This Agreement constitutes the entire agreement between you and Freescale regarding the subject matter of this Agreement, and supersedes all prior communications, negotiations, understandings, agreements or representations, either written or oral, if any. This Agreement may only be amended in written form, executed by you and Freescale.

**SEVERABILITY.** If any provision of this Agreement is held for any reason to be invalid or unenforceable, then the remaining provisions of this Agreement will be unimpaired and, unless a modification or replacement of the invalid or unenforceable provision is further held to deprive you or Freescale of a material benefit, in which case the Agreement will immediately terminate, the invalid or unenforceable provision will be replaced with a provision that is valid and enforceable and that comes closest to the intention underlying the invalid or unenforceable provision.

**NO WAIVER.** The waiver by Freescale of any breach of any provision of this Agreement will not operate or be construed as a waiver of any other or a subsequent breach of the same or a different provision.