

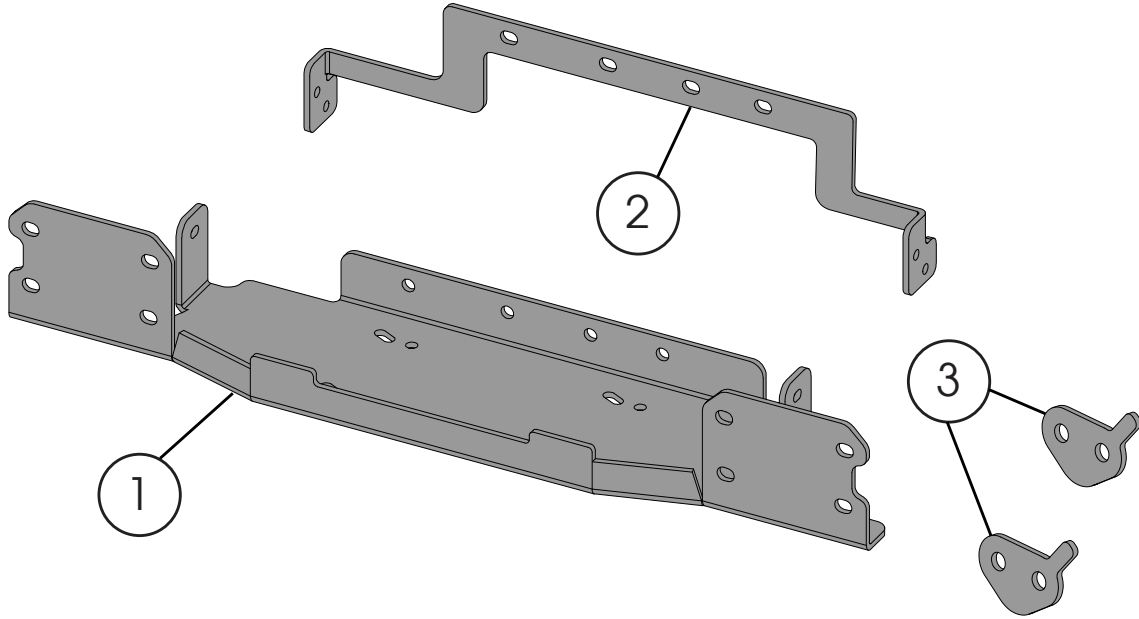

OMIX-ADA, Inc.

Part #11543.16

JL Winch Plate



Components

- 1. Winch Plate
- 2. Bottom Plate

- (1) 3. Spacer
- (1)

(2)

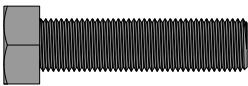

1/2" Bolt (4)

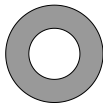

1/2" Washer (8)



1/2" Nut (4)

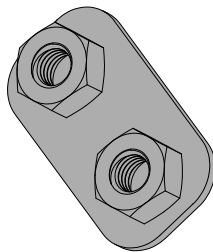

Nut Plate (2)



3/8" Bolt (6)



3/8" Washer (6)



JL Winch Plate

1. Disconnect fog lights and remove factory bumper, lower air dam, center cover, and lower cross bracket.

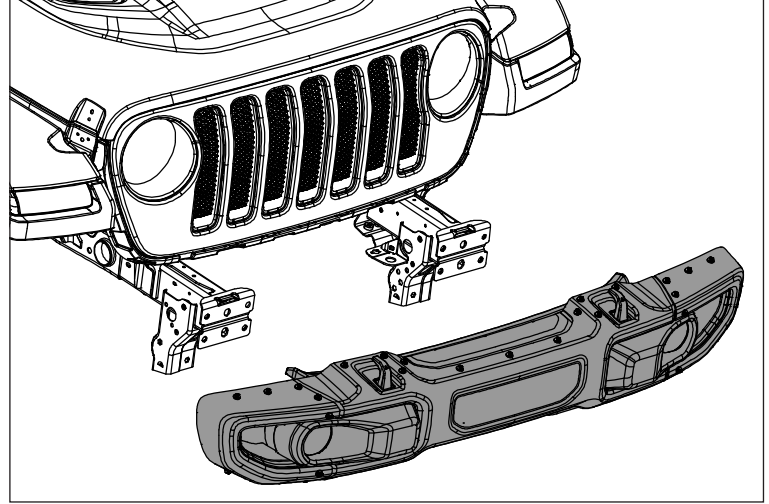

2. Remove OE Inner Frame Horn Bracket. Loosely attach Winch Plate reusing OE bolts.

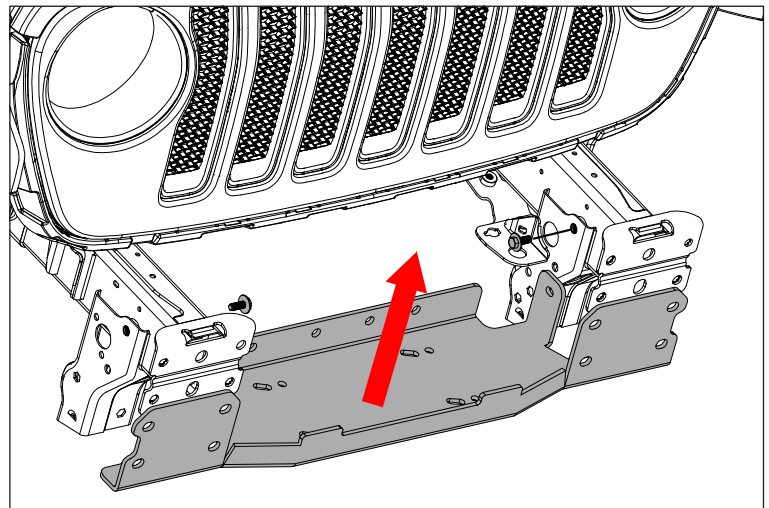

NOTICE Skip to Step 4 if installing Rugged Ridge Spartacus Front Bumper

NOTICE **Optional:** if reinstalling OE lower air dam the lower air bracket will need to be modified.

3. Remove OE Lower Air Dam Brackets, and set hardware aside. Using drimel and drill, slot factory brackets as shown. Deburr area and paint to reduce the likelihood of corrosion.

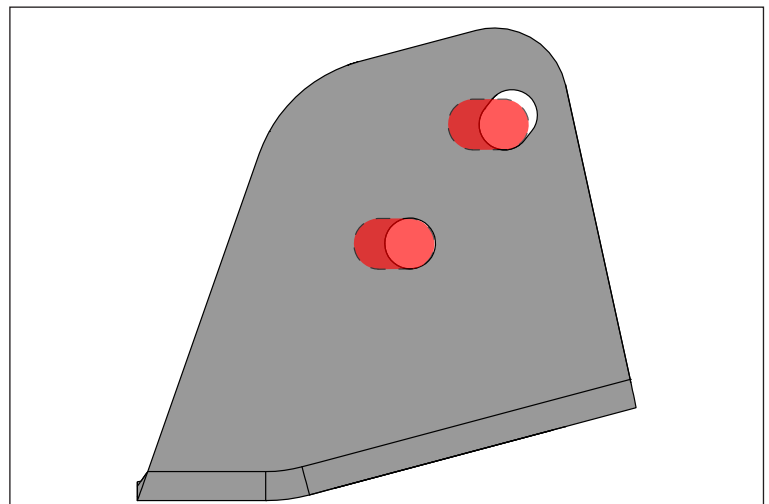



JL Winch Plate

4. Loosely attach Bottom Plate to Winch Plate using supplied 1/2" hardware.

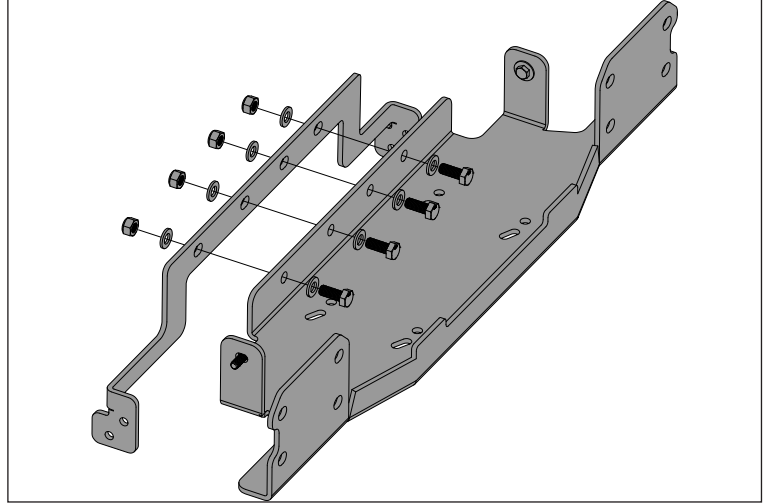

5. **Mopar Steel Bumper:** Using OE bolts and slotted Air Dam Brackets, loosely attach Bottom Plate to lower cross member.

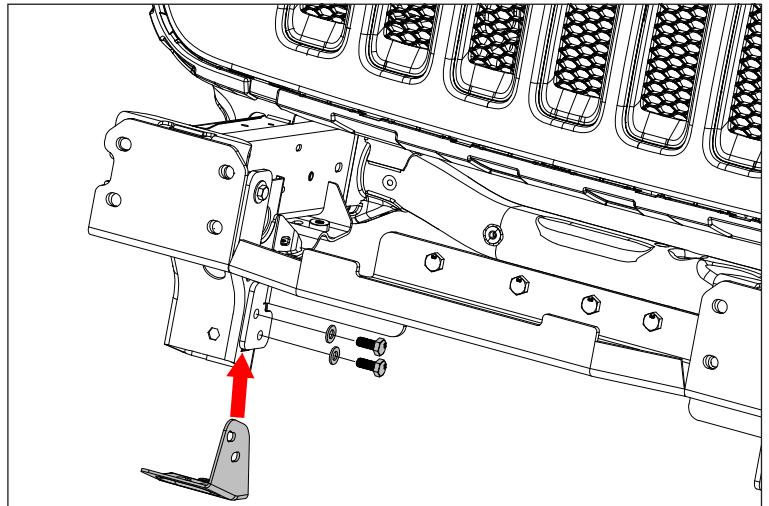

Rugged Ridge Bumper: Using supplied spacer, nut plate, and supplied 3/8" hardware, loosely attach Bottom Plate to lower cross member.

NOTICE If installing Rugged Ridge Spartacus Front Bumper, complete steps 2-4 on Front Bumper Instructions. Then complete Winch Plate Instruction Step 6.

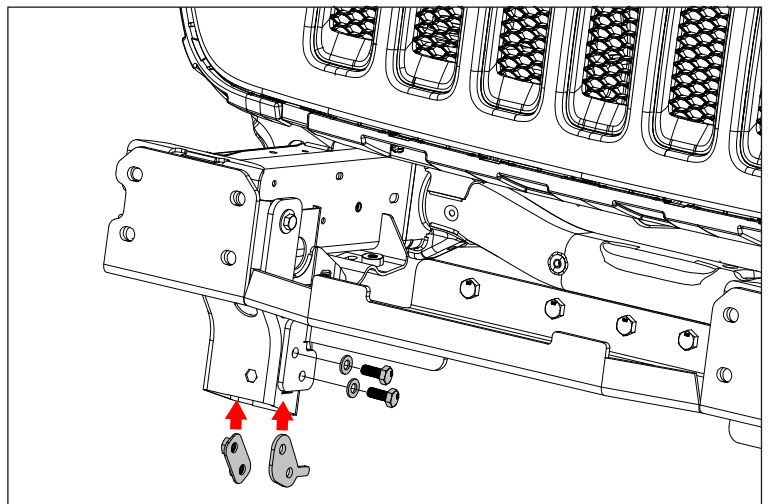

**Rugged
Ridge**



ALLOY
USA

JL Winch Plate

6. Tighten Winch Plate hardware. Install Winch on Winch Plate.

NOTICE

If installing Rugged Ridge Spartacus Front Bumper, complete steps 7-12 on Front Bumper Instructions.

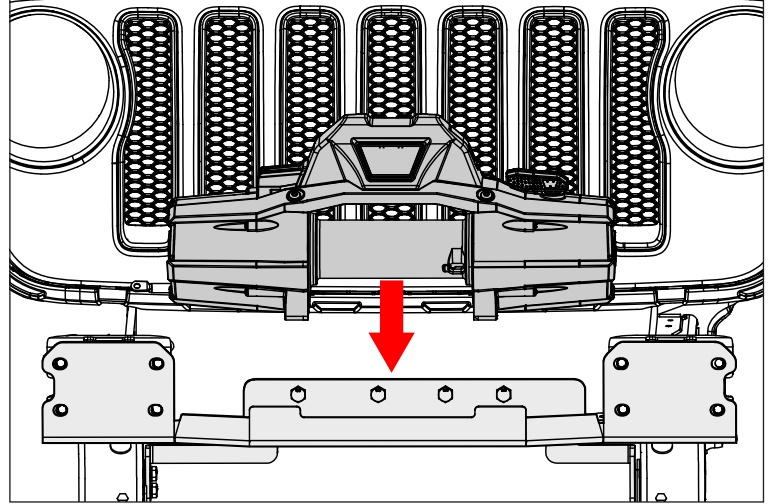

7. Remove factory winch delete plate and fairlead cover plate from Mopar Steel Bumper. Position Bumper on Frame Horn and Bottom Plate using Factory Tow Hook. Loosely attach with factory nuts. Tighten all Bolts. Attach lower air dam

