

# SCHOENFELD

*Headers*

Performance • Quality • Value



# 2019

# RACING CATALOG



Made in USA

# INDEX

## Small Block Chevy

Boat/Marine.....	22
Chassis.....	6
Crossover.....	3,4
Demolition Derby.....	36
Dirt Late Model.....	19-21
<b>Dirt Late Model Tri-Y.....</b>	<b>19</b>
D.I.R.T. Modified.....	33
Drag.....	7,9,10,11
IMCA-Modified.....	6,12-18
LS1.....	5,23,33,34,36
<b>LS1 Dirt Late Model Tri-Y.....</b>	<b>22</b>
Midget.....	28
Sprint/Dyno.....	23-26
<b>Sprint/Dyno Tri-Y.....</b>	<b>24</b>
Street Stock/Stock Clip.....	6-11
Truck.....	34-36
Zoomie.....	5

## Big Block Chevy

Dyno/Sprint.....	23
Truck.....	35,36

## Ford

2000cc & 2300cc.....	11
<b>2000cc &amp; 2300cc Tri-Y.....</b>	<b>11</b>
Crossover.....	4
Demolition Derby.....	36
Dirt Late Model.....	22
Esslinger Midget.....	27
Focus Midget.....	29
IMCA-Modified.....	12,16,17
Sprint/Dyno.....	23,26
Stock Clip.....	8
Street Stock.....	10
Truck.....	10,36

## Mopar

Demolition Derby.....	36
<b>Midget Merge.....</b>	<b>29</b>
Sprint/Dyno.....	26
Truck.....	36

## Micro Sprint

Yam.,Hon.,Kaw.,Suzuki.....	31,32
----------------------------	-------

## Mod-Lite

Suzuki.....	32
-------------	----

## Gaskets & Flanges

SB Chevy.....	38,39
BB Chevy.....	39
Collector Rings.....	41
6 Cylinder Chevy.....	39
Ford.....	39,40
Mopar.....	40
Toyota.....	39

## Miscellaneous

Applications (Chassis).....	37
Applications (Elbow).....	45
Bungs.....	41
Collectors.....	42,43,45
Elbows.....	44,45
Extensions.....	44,45
U & J Bends.....	41
Header Bolts.....	41
Merge Collectors.....	42
Misc. Bends.....	41
Mufflers.....	31,32,46,47
Reducers.....	41,46
Special Pricing.....	47
Tab Kits.....	44
Turnouts.....	44
2x2 and 2x1 Collectors.....	45
2 Into 1 Y Pipes.....	43,45
Micro Mufflers.....	31,32

## Conventional Crossover Tri-Y

4 Into 2 Into 1 Tube Configuration for Increased Torque  
Fits Hamke, Howe, Lefthander & Port City

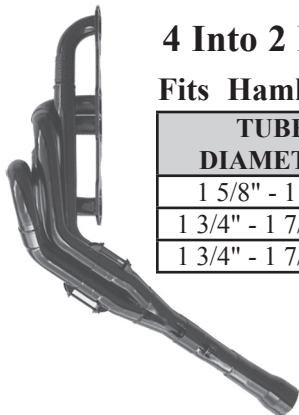

TUBE DIAMETER	COLLECTOR DIA.	STANDARD CHEVY #	*CRATE MOTOR #	CHEVY 18° #
1 5/8" - 1 3/4"	3"	135VY	135VYCM	----
1 3/4" - 1 7/8" - 2"	3 1/2"	136V3Y	----	----
1 3/4" - 1 7/8" - 2"	3 1/2"	----	----	136V3Y18

For extension (elbow) applications see page 44-45

Fits Jerico Trans.  
Bolts and Gaskets included  
Comes With 5/16" Flange  
\* = 604 Crate Motor  
Temporary non-high temperature paint

## Conventional Crossover Headers

SB Chevy - Fits Bemco, Coleman, Hamke, Howe, Lefthander and Port City

TUBE DIAMETER	COLLECTOR DIA./LENGTH	STANDARD CHEVY #	"H" STYLE #	*CRATE MOTOR #	CHEVY 18° #
1 1/2" - 1 5/8"	3" x 8"	134V	134VH	----	----
1 5/8"	3" x 8"	135	135H	135CM2	----
1 5/8" - 1 3/4"	3 1/2" x 8"	135V	135VH	135VCM	----
1 5/8" - 1 3/4"	3" x 8"	135V-3	135VH-3	135VCM-3	----
1 3/4"	3 1/2" x 8"	136	136H	136CM	----
1 3/4" - 1 7/8"	3 1/2" x 9"	136V	136VH	136VCM	136V18
1 3/4" - 2"	3 1/2" x 9"	136V2	136V2H	----	136V2-18
1 3/4" - 1 7/8" - 2"	3 1/2" x 9"	136V3	136V3H	----	136V3-18

H-style fits Howe, Port City and stock clip cars.  
(Different #7 cylinder)

Fits Jerico Trans.  
Available for GARC chassis  
\*CM2 = 602 Crate Motor  
\* = 604 Crate Motor



H Style

For extension (elbow) applications see page 44-45

Bolts and Gaskets included

## Conventional Crossover Headers (cont.)

CNC laser cut flanges available to fit 18° Brodix spread port and Spread Port.

Dart, Pontiac 867 and Stahl pattern heads.

SB Chevy (will not fit Lefthander fab chassis)

TUBE DIAMETER	COLLECTOR DIA./LENGTH	STANDARD CHEVY #	*CRATE MOTOR #
1 1/2" - 1 5/8"	3" x 8"	<b>144V</b>	----
1 5/8"	3" x 8"	<b>145</b>	<b>145CM2</b>
1 5/8" - 1 3/4"	3 1/2" x 8"	<b>145V</b>	<b>145VCM</b>
1 5/8" - 1 3/4"	3" x 8"	<b>145V-3</b>	<b>145VCM-3</b>
1 3/4"	3 1/2" x 8"	<b>146</b>	<b>146CM</b>
1 3/4" - 1 7/8"	3 1/2" x 9"	<b>146V</b>	<b>146VCM</b>
1 3/4" - 1 7/8" - 2"	3 1/2" x 9"	<b>146V3</b>	----

\* = 604 Crate Motor

\*CM2 = 602 Crate Motor



## Ford Crossover

TUBE DIAMETER	COLLECTOR DIA./LENGTH	289-302-351 WINDSOR #	DART/"N" SPORTSMAN #	CRATE MOTOR #
1 5/8"	3" x 8"	<b>335</b>	<b>*335N</b>	<b>335CM</b>
1 5/8" - 1 3/4"	3 1/2" x 8"	<b>335V</b>	<b>*335VN</b>	<b>335VCM</b>
1 5/8" - 1 3/4"	3" x 8"	<b>335V-3</b>	<b>*335VN-3</b>	<b>335VCM-3</b>
1 3/4"	3 1/2" x 9"	<b>336</b>	<b>*336N</b>	<b>336CM</b>
1 3/4" - 1 7/8"	3 1/2" x 9"	<b>336V</b>	<b>*336VN</b>	<b>336VCM</b>

(\*Fits wide Dart bolt pattern and Sportsman "N" head)

Available for Edelbrock

**CM** Fits Z304 Headed Crate motor

Bolts and Gaskets included

Temporary non-high temperature paint



## Ford Tri Y Crossover

TUBE DIAMETER	COLLECTOR DIA.	289-302-351 WINDSOR #	DART/"N" SPORTSMAN #	EDLE/MCGUN #
1 5/8" - 1 3/4"	3"	<b>335VY</b>	<b>335VYN</b>	<b>335VYE</b>
1 3/4" - 1 7/8" - 2"	3 1/2"	<b>336V3Y</b>	<b>336V3YN</b>	<b>336V3YE</b>



Temporary non-high temperature paint

For extension (elbow) applications see page 44-45

Bolts and Gaskets included

Comes With 5/16" Flange

## LS1-LS7 Crossover

SB Chevy - Fits Bemco, Coleman, Hamke, Howe, Lefthander and Port City

TUBE DIAMETER	COLLECTOR DIA./LENGTH	LS1-LS7 #
1 5/8"	3" x 8"	<b>135LS1</b>
1 3/4"	3 1/2" x 8"	<b>136LS1</b>
1 3/4"	3" x 8"	<b>136LS1-3</b>
1 3/4" - 1 7/8"	3 1/2" x 9"	<b>136VLS1</b>



For extension (elbow) applications  
see page 44-45

Fits Jerico Trans.  
Bolts and Gaskets included

Temporary non-high temperature paint

## Chevy 180° Crossover



Exits thru lower right door.  
Uses 46" extension.

TUBE DIAMETER	COLLECTOR DIA./LENGTH	STANDARD CHEVY #
1 5/8"	3" x 8"	<b>179-1</b>
1 5/8" - 1 3/4"	3 1/2" x 9"	<b>179V-1</b>
1 3/4"	3 1/2" x 9"	<b>180-1</b>

For extension (elbow) applications see page 44-45  
Bolts and Gaskets included  
Temporary non-high temperature paint

## Zoomie Grassburner

Fits Chevy Late Model, IMCA type modified,  
Camaro, Chevelle, etc.



TUBE SIZE	STANDARD CHEVY #
1 3/4"	<b>130</b>

Bolts and Gaskets included



## Chevy Chassis Headers

Fits older Bullitt, GRT, Howe, NASCAR LMS, Shaw, and most IMCA Modifieds.  
Fits angle plug or straight plug heads, #1 spark plug needs to be at least 1" behind ball

TUBE DIAMETER	COLLECTOR DIA./LENGTH	STANDARD CHEVY #	CRATE MOTOR #	SPREAD PORT #
1 5/8"	3" x 8"	<b>*151</b>	<b>*151CM2</b>	----
1 5/8" - 1 3/4"	3 1/2" x 8"	<b>151V</b>	<b>151VCM</b>	----
1 3/4"	3" x 8"	<b>152-3</b>	<b>152CM-3</b>	----
1 3/4"	3 1/2" x 8"	<b>152</b>	<b>152CM</b>	----
1 3/4" - 1 7/8"	3 1/2" x 9"	<b>152V</b>	<b>152VCM</b>	<b>152VSP</b>
1 7/8"	3 1/2" x 9"	<b>153</b>	-----	<b>153SP</b>



Bolts and Gaskets included

\*NASCAR LMS Legal  
CM2 = 602 Crate Motor

151EL - 30" Primaries. Closer to equal length than 151 style.

TUBE DIAMETER	COLLECTOR DIA./LENGTH	STANDARD CHEVY #	CRATE MOTOR #
1 5/8"	3" x 8"	<b>*151E</b>	<b>*151ECM2</b>
1 5/8"	3" x 8"	<b>*151EL</b>	<b>*151ELCM2</b>
1 5/8" - 1 3/4"	3 1/2" x 8"	<b>151EV</b>	-----
1 3/4"	3" x 8"	<b>152E-3</b>	<b>152ECM-3</b>
1 3/4"	3 1/2" x 8"	<b>152E</b>	<b>152ECM</b>
1 3/4" - 1 7/8"	3 1/2" x 9"	<b>152EV</b>	<b>152EVCM</b>

151EL

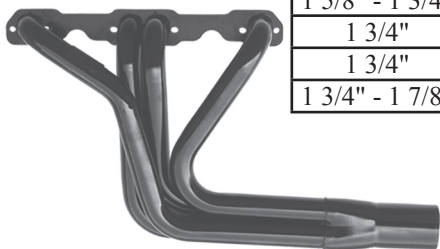

Ford Available  
151E

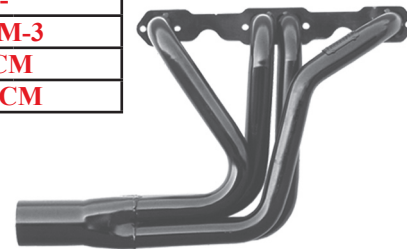

Bolts and Gaskets included  
\*NASCAR LMS Legal

\*CM2 = 602 Crate Motor  
Temporary non-high temperature paint

## Chevy Stock Clip Header

Fits Straight or Angle plug heads.

Long Tube Design

TUBE DIAMETER	COLLECTOR DIA./LENGTH	STANDARD CHEVY #	*CRATE MOTOR #
1 5/8" - 1 3/4" - 1 7/8"	3 1/2" x 9"	<b>155LV3</b>	<b>155LV3CM</b>
1 5/8" - 1 3/4" - 1 7/8"	3" x 9"	<b>155LV3-3</b>	<b>155LV3CM-3</b>

Exits over frame rail. (Both sides)  
Bolts and Gaskets included  
Fits straight or angle plug heads.



## Chevy Stock Clip Header



Right side front view

Right side top view

TUBE DIAMETER	COLLECTOR DIA./LENGTH	STANDARD CHEVY #	*CRATE MOTOR #
1 5/8"	3" x 8"	<b>155</b>	<b>155CM2</b>
1 5/8" - 1 3/4"	3 1/2" x 8"	<b>155V</b>	<b>155VCM</b>
1 5/8" - 1 3/4"	3" x 8"	<b>155V-3</b>	<b>155VCM-3</b>
1 3/4"	3 1/2" x 8"	<b>156</b>	<b>156CM</b>
1 3/4"	3" x 8"	<b>156-3</b>	-----
1 3/4" - 1 7/8"	3 1/2" x 9"	<b>156V</b>	<b>156VCM</b>
1 7/8"	3 1/2" x 9"	<b>157</b>	-----

Fits straight or angle plug heads.  
Spread port Available

Exits over frame rail. (Both sides)  
Bolts and Gaskets included

\* = 604 Crate Motor  
\*CM2 = 602 Crate Motor

TUBE DIAMETER	COLLECTOR DIA./LENGTH	STANDARD CHEVY #	SPREAD PORT #
1 5/8"	3" x 8"	<b>125</b>	-----
1 5/8" - 1 3/4"	3 1/2" x 8"	<b>125V</b>	-----
1 5/8" - 1 3/4"	3" x 8"	<b>125V-3</b>	-----
1 3/4"	3 1/2" x 8"	<b>126</b>	-----
1 3/4"	3" x 8"	<b>126-3</b>	-----
1 3/4" - 1 7/8"	3 1/2" x 9"	<b>126V</b>	<b>126VSP</b>

Fits straight or angle plug heads.  
Exits over frame rail. (Both sides)  
Will not fit with stock upper control arms.  
Engine must be moved back.  
Bolts and Gaskets included  
Temporary non-high temperature paint



Mopar Available

## Camaro Stock Clip



Must use stock height springs.

\* = 604 Crate Motor  
\*CM2 = 602 Crate Motor

TUBE DIAMETER	COLL. DIA./LENGTH	STANDARD PORT #	*CRATE MOTOR #
1 5/8"	3" x 8"	<b>103</b>	<b>103CM2</b>
1 5/8" - 1 3/4"	3" x 8"	<b>103V-3</b>	<b>103VCM-3</b>
1 5/8" - 1 3/4"	3 1/2" x 8"	<b>103V</b>	<b>103VCM</b>
1 3/4"	3" x 8"	<b>104-3</b>	<b>104CM-3</b>
1 3/4"	3 1/2" x 8"	<b>104</b>	<b>104CM</b>
1 3/4" - 1 7/8"	3 1/2" x 9"	<b>104V</b>	<b>104VCM</b>

## Metric Stock Clip

TUBE DIAMETER	COLL. DIA./LENGTH	STANDARD CHEVY #	*CRATE MOTOR #
1 5/8"	3" x 8"	<b>107</b>	<b>107CM2</b>
1 5/8" - 1 3/4"	3" x 8"	<b>107V-3</b>	<b>107VCM-3</b>
1 5/8" - 1 3/4"	3 1/2" x 8"	<b>107V</b>	-----
1 3/4"	3" x 8"	<b>108-3</b>	<b>108CM-3</b>
1 3/4"	3 1/2" x 8"	<b>108</b>	<b>108CM</b>
1 3/4" - 1 7/8"	3 1/2" x 9"	<b>*108V</b>	<b>108VCM</b>
1 7/8"	3 1/2" x 9"	<b>109</b>	-----
1 7/8" - 2"	3 1/2" x 9"	<b>*109V</b>	-----

Bolts and Gaskets included  
\*Spread Port & 18° available



Must use stock height springs.

\* = 604 Crate Motor  
\*CM2 = 602 Crate Motor



## Ford Stock Clip Header

### Ford

TUBE DIAMETER	COLLECTOR DIA./LENGTH	WINDSOR 289-302-351	DART/"N" SPORTSMAN
1 5/8" - 1 3/4"	3 1/2" x 8"	<b>355V</b>	<b>*355VN</b>
1 3/4"	3 1/2" x 8"	<b>356</b>	<b>*356N</b>
1 3/4" - 1 7/8"	3 1/2" x 9"	<b>356V</b>	<b>*356VN</b>

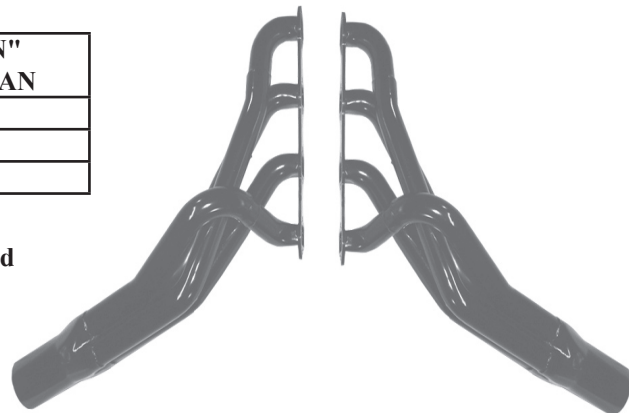

\*Fits the wide Dart Bolt Pattern and Sportsman "N" head  
(Available for Edelbrock)  
Bolts and Gaskets included  
Temporary non-high temperature paint

Exits over frame rail. (Both sides)

## Chevy Stock Car IMCA - UMP

Exits inside frame rail

No clearance issues with oil filter, spark plugs, starter, kick out oil pan, rear mounts, valve covers.  
Clears firewall that is minimum 7" from back of block.

Fits Harris, Jet, Victory

TUBE DIAMETER	COLLECTOR DIA./LENGTH	STANDARD CHEVY #	*CRATE MOTOR #	SPREAD PORT & 18° CHEVY
1 5/8"	3" x 8"	<b>195</b>	<b>195CM2</b>	-----
1 5/8" - 1 3/4"	3" x 8"	<b>195V-3</b>	<b>195VCM-3</b>	-----
1 3/4"	3" x 8"	<b>196-3</b>	<b>196CM-3</b>	-----
1 3/4" - 1 7/8"	3 1/2" x 9"	<b>196V</b>	<b>196VCM</b>	<b>196VSP - 196V18</b>

Bolts and Gaskets included  
80 degree elbow available - part # 3081  
\* = 604 Crate Motor  
CM2 = 602 Crate Motor  
Exits outside frame rail

TUBE DIAMETER	COLLECTOR DIA./LENGTH	STANDARD CHEVY #	*CRATE MOTOR #
1 5/8"	3" x 8"	<b>197</b>	<b>197CM2</b>
1 5/8" - 1 3/4"	3" x 8"	<b>197V-3</b>	<b>197VCM-3</b>
1 3/4"	3" x 8"	<b>198-3</b>	<b>198CM-3</b>
1 3/4" - 1 7/8"	3 1/2" x 9"	<b>198V</b>	<b>198VCM</b>

Bolts and Gaskets included

Schoenfeld headers are not legal for sale or use on any pollution controlled vehicle intended for street or highway use.

Chassis Applications | Midget | Sprint | Dirt Late Model | IMCA Mod. | Chassis | Street Stock | Stock Clip | 180° Crossover | Crossover | Tractor/Derby | Tractor/Derby  
Mufflers | Elbow Applications | Misc. | Turnouts & Extensions | X & Y Pipes | U & J Bends | Flanges/Gaskets | Collectors | Drag | 4 Cyl. | Dirt Mod.



## Chevy Street Stock

1973 - 1988 Chevy Malibu, Monte Carlo, Pontiac Grand Prix, Olds Cutlass, Buick Regal. Also Camaro, 70 - 81

Can use solid side and rear mounts.

WILL FIT straight or angle plug heads, fit with some mini starters, fit some kick-out oil pans, short oil filter.

TUBE DIAMETER	COLLECTOR DIA./LENGTH	STANDARD CHEVY #	*CRATE MOTOR #	SPREAD PORT #	CHEVY 18° #
1 1/2" - 1 5/8"	3" x 8"	<b>184V</b>	----	----	----
1 5/8"	3" x 8"	<b>185</b>	<b>185CM2</b>	----	----
1 5/8" - 1 3/4"	3" x 8"	<b>185V</b>	<b>185VCM</b>	----	----
1 3/4"	3 1/2" x 8"	<b>186</b>	<b>186CM</b>	----	----
1 3/4"	3" x 8"	<b>186-3</b>	<b>186CM-3</b>	----	----
1 3/4" - 1 7/8"	3 1/2" x 9"	<b>186V</b>	<b>186VCM</b>	<b>186VSP</b>	<b>186V18</b>
1 7/8"	3 1/2" x 9"	<b>187</b>	----	<b>187SP</b>	<b>187-18</b>



CM2 = 602 Crate Motor  
Oil Filters Such As:  
Wix 51069 - AC PF24  
Designed to fit with engine in stock location.  
\* = 604 Crate Motor



Bolts and Gaskets included

1973 - 1988 Chevy Malibu, Monte Carlo, Pontiac Grand Prix, Olds Cutlass, Buick Regal. Also Camaro 70 - 81.

Clears side and rear engine mounts.

WILL FIT straight or angle plug heads.

WILL CLEAR stock manual clutch linkage ball.

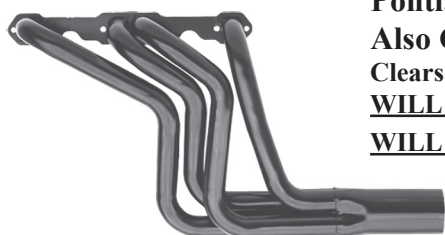

Must use short oil filter.

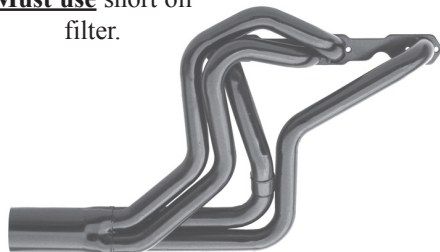

Spread port & 18° available for 1 3/4" & 1 7/8"

TUBE DIAMETER	COLLECTOR DIA./LENGTH	STANDARD CHEVY #	*CRATE MOTOR #
1 1/2" - 1 5/8"	3" x 8"	<b>184VM</b>	----
1 5/8"	3" x 8"	<b>185M</b>	<b>185MCM2</b>
1 5/8" - 1 3/4"	3" x 8"	<b>185VM</b>	<b>185VMCM</b>
1 3/4"	3 1/2" x 8"	<b>186M</b>	<b>186MCM</b>
1 3/4"	3" x 8"	<b>186M-3</b>	<b>186MCM-3</b>
1 3/4" - 1 7/8"	3 1/2" x 9"	<b>186VM</b>	<b>186VMCM</b>
1 7/8"	3 1/2" x 9"	<b>187M</b>	----

Designed to fit with engine in stock location.

\* = 604 Crate Motor

CM2 = 602 Crate Motor

Bolts and Gaskets included

### Street Stock

**Camaro 70 - 81, Chevy II, Nova 75-79  
Chevelle 64 - 77, Monte Carlo 72 - 77**

TUBE DIAMETER	COLLECTOR DIA./LENGTH	STANDARD CHEVY #
1 5/8"	3" x 8"	<b>165</b>
1 5/8" - 1 3/4"	3" x 8"	<b>165V</b>
1 3/4"	3 1/2" x 8"	<b>166</b>
1 3/4"	3" x 8"	<b>166-3</b>

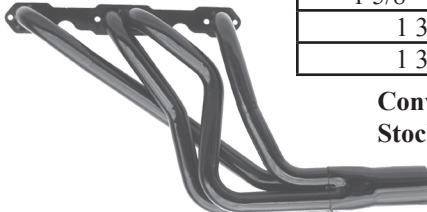

Conventional Style Headers for Car with Engines in Stock Location or engine set back.

**WILL NOT** fit angle plug heads.  
**WILL NOT** clear rear mounts.

### Camaro 70-81, Monte Carlo 72-77, Nova 75-79 Will Not Fit Chevelle

TUBE DIAMETER	COLLECTOR DIA./LENGTH	STANDARD CHEVY #	*CRATE MOTOR #	SPREAD PORT #
1 5/8"	3" x 8"	<b>165A</b>	<b>165ACM2</b>	----
1 5/8" - 1 3/4"	3" x 8"	<b>165VA</b>	<b>165VACM</b>	----
1 3/4"	3 1/2" x 8"	<b>166A</b>	<b>166ACM</b>	----
1 3/4"	3" x 8"	<b>166A-3</b>	<b>166ACM-3</b>	----
1 3/4" - 1 7/8"	3 1/2" x 9"	<b>166VA</b>	<b>166VACM</b>	<b>166VASP</b>
1 7/8"	3 1/2" x 9"	<b>167A</b>	-----	<b>167ASP</b>

FITS straight or angle plug heads, solid side and rear mounts, stock clutch linkage.

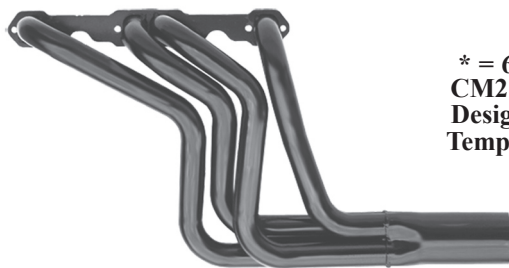

\* = 604 Crate Motor  
CM2 = 602 Crate Motor  
Designed to fit with engine in stock location.  
Temporary non-high temperature paint

### Ford Street Stock / Truck

Designed to fit Camaro, Intermediate GM, Front Clips.

TUBE DIAMETER	COLLECTOR DIA./LENGTH	WINDSOR 289-302-351	CRATE MOTOR	DART/ "N" SPORTSMAN
1 5/8"	3" x 8"	<b>385</b>	<b>385CM</b>	<b>*385N</b>
1 5/8" - 1 3/4"	3" x 8"	<b>385V</b>	<b>385VCM</b>	<b>*385VN</b>
1 3/4"	3 1/2" x 8"	<b>386</b>	<b>386CM</b>	<b>*386N</b>

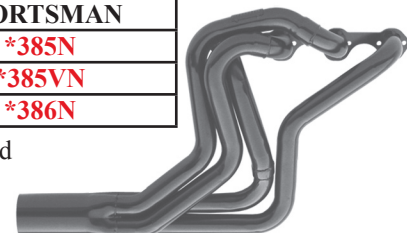
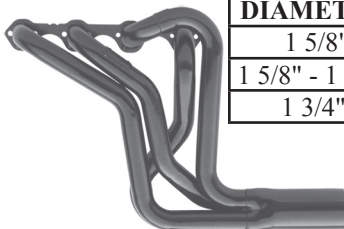

\*Fits the wide Dart Bolt Pattern and Sportsman "N" head  
(Available for Edelbrock)  
Fits Ford Trucks 1967-1972

Tractor/Derby  
Dirt Mod.  
Crossover  
Drag 4 Cyl.  
Crossover  
Collectors  
180° Crossover  
Flanges/Gaskets  
Stock Clip  
U & J Bends  
Street Stock  
Chassis  
IMCA Mod.  
X & Y Pipes  
Turnouts & Extensions  
Dirt Late Model  
Sprint  
Misc.  
Midget  
Elbow Applications  
Chassis Applications  
Mufflers

## Chevy Drag "Street Class"

### Camaro 1967-1969



TUBE DIAMETER	COLLECTOR DIA./LENGTH	STANDARD CHEVY #
1 5/8"	3" x 8"	<b>115</b>
1 5/8" - 1 3/4"	3 1/2" x 8"	<b>115V</b>
1 5/8" - 1 3/4"	3" x 8"	<b>115V-3</b>
1 3/4"	3 1/2" x 8"	<b>116</b>
1 3/4"	3" x 8"	<b>116-3</b>
1 3/4" x 1 7/8"	3 1/2" x 9"	<b>116V</b>

Fits Motor in stock location, straight plug heads, stock clutch linkage.

## 2300cc Ford Pinto Tri - Y Headers

TUBE DIAMETER	COLLECTOR DIAMETER	2300CC #
1 1/2" - 1 5/8"	3"	<b>F232VY</b>
1 5/8" - 1 3/4"	3"	<b>F233VY</b>

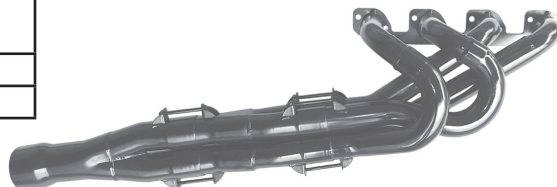

Bolts and Gaskets included  
Temporary non-high temperature paint

## 2000cc & 2300cc Ford Pinto Headers

“Pro Four” Tube Chassis Style or goes through Firewall on production Pinto or Mustang.

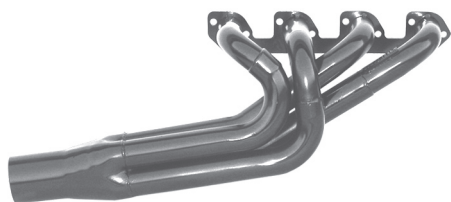

TUBE DIAMETER	COLLECTOR DIA./LENGTH	2300CC #	2000CC #
1 1/2" - 1 5/8"	3" x 8"	<b>F234V</b>	<b>F204V</b>
1 5/8" - 1 3/4"	3" x 8"	<b>F235V</b>	<b>F205V</b>
GASKETS	-----	<b>FG23</b>	<b>FG20</b>

Bolts and Gaskets included  
Temporary non-high temperature paint

Production Chassis type:  
(exits under car on production Pinto or Mustang)  
Will not clear 2.0 stock motor mounts.

TUBE DIAMETER	COLLECTOR DIA./LENGTH	2300CC #	2000CC #
1 1/2" - 1 5/8"	3" x 8"	<b>F238V</b>	<b>F208V</b>
1 5/8" - 1 3/4"	3" x 8"	<b>F239V</b>	<b>F209V</b>
GASKETS	-----	<b>FG23</b>	<b>FG20</b>



Bolts and Gaskets included  
Temporary non-high temperature paint

Also fits Ford Ranger 1983-1992

## Chevy Modified

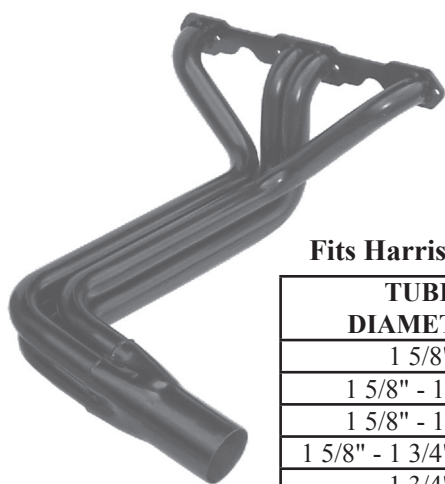

Fits Harris, Skyrocket, Victory.

TUBE DIAMETER	COLLECTOR DIA./LENGTH	STANDARD CHEVY #	*CRATE MOTOR #
1 5/8"	3" x 8"	<b>11619H</b>	<b>11619HCM2</b>
1 5/8" - 1 3/4"	3 1/2" x 8"	<b>1161V9H</b>	<b>1161V9HCM</b>
1 5/8" - 1 3/4"	3" x 8"	<b>1161V9H-3</b>	<b>1161V9HCM-3</b>
1 5/8" - 1 3/4" - 1 7/8"	3" x 9"	<b>1161V39H-3</b>	<b>1161V39HCM-3</b>
1 3/4"	3 1/2" x 8"	<b>11629H</b>	<b>11629HCM</b>
1 3/4" - 1 7/8"	3 1/2" x 8"	<b>1162V9H</b>	<b>1162V9HCM</b>

Bolts and Gaskets included

\* = 604 Crate Motor

\*CM2 = 602 Crate Motor

## Modified Mid-Length Primary Design

### Chevy

Fits BMS, Dirtworks, GRT, Harris, Hoffman, Jet Racing, Larry Shaw. (Pierce uses 1106A style)

TUBE DIAMETER	COLLECTOR DIA./LENGTH	STANDARD CHEVY #	*CRATE MOTOR #	SPREAD PORT/D.N #	CHEVY 18° #
1 5/8"	3" x 8"	<b>1105</b>	<b>1105CM2</b>	----	----
1 5/8" - 1 3/4"	3 1/2" x 8"	<b>1105V</b>	<b>1105VCM</b>	----	----
1 5/8" - 1 3/4"	3" x 8"	<b>1105V-3</b>	<b>1105VCM-3</b>	----	----
1 3/4"	3 1/2" x 8"	<b>1106</b>	<b>1106CM</b>	<b>1106SP</b>	----
1 3/4" - 1 7/8"	3 1/2" x 9"	<b>1106V</b>	<b>1106VCM</b>	<b>1106VSP</b>	<b>1106V18</b>

\* = 604 Crate Motor

\*CM2 = 602 Crate Motor

**Smoother Power Band**

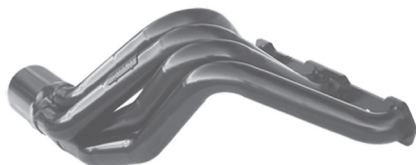

### Ford

Fits BMS, Dirtworks, GRT, Harris, Hoffman, Jet Racing, Larry Shaw.

TUBE DIAMETER	COLLECTOR DIA./LENGTH	WINDSOR 289-302-351 #	DART "N" #
1 5/8"	3" x 8"	<b>3105</b>	<b>3105N</b>
1 5/8" - 1 3/4"	3 1/2" x 8"	<b>3105V</b>	<b>3105VN</b>
1 5/8" - 1 3/4"	3" x 8"	<b>3105V-3</b>	<b>3105VN-3</b>
1 3/4"	3 1/2" x 8"	<b>3106</b>	<b>3106N</b>
1 3/4" - 1 7/8"	3 1/2" x 9"	<b>3106V</b>	<b>3106VN</b>

## Modified Long-Tube Design

Fits BMS, Dirtworks, Hoffman, Hot, Jet, KMOD, Bob Pierce, Pro, Quick, Sardeson, Smiley's, Victory.

TUBE DIAMETER	COLLECTOR DIA./LENGTH	STANDARD CHEVY #	*CRATE MOTOR #	SPREAD PORT #	CHEVY 18° #
1 5/8"	3" x 8"	<b>1185</b>	<b>1185CM2</b>	----	----
1 5/8" - 1 3/4"	3 1/2" x 8"	<b>1185V</b>	<b>1185VCM</b>	----	----
1 5/8" - 1 3/4"	3" x 8"	<b>1185V-3</b>	<b>1185VCM-3</b>	----	----
1 5/8" - 1 3/4" - 1 7/8"	3" x 9"	<b>1185V3-3</b>	<b>1185V3CM-3</b>	----	----
1 3/4"	3 1/2" x 8"	<b>1186</b>	<b>1186CM</b>	<b>1186SP</b>	----
1 3/4" - 1 7/8"	3 1/2" x 9"	<b>1186V</b>	<b>1186VCM</b>	<b>1186VSP</b>	<b>1186V18</b>

Available in LS1-LS7

Bolts and Gaskets included

\* = 604 Crate Motor

\*CM2 = 602 Crate Motor

Temporary non-high temperature paint

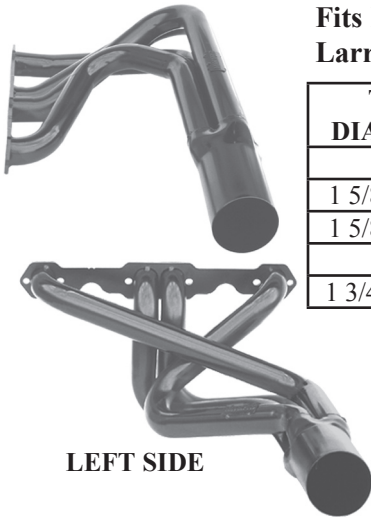
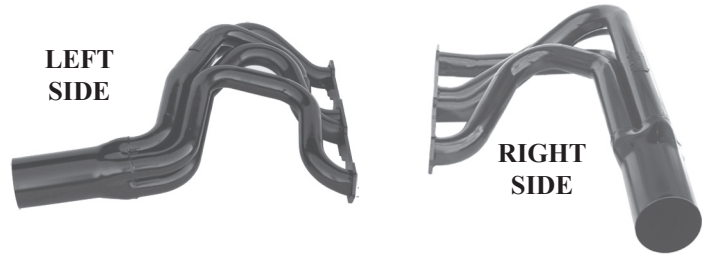

Fits BMS, Bob Pierce, Dirtworks, Harris, Hoffman, Hot, Hughes, Jet, Larry Shaw, Lightning, Lou Fegers, M&M, Pro, Sardeson.

TUBE DIAMETER	COLLECTOR DIA./LENGTH	STANDARD CHEVY #	SPREAD PORT #	*CRATE MOTOR #
1 5/8"	3" x 8"	<b>1175</b>	----	<b>1175CM2</b>
1 5/8" - 1 3/4"	3 1/2" x 8"	<b>1175V</b>	----	<b>1175VCM</b>
1 5/8" - 1 3/4"	3" x 8"	<b>1175V-3</b>	----	<b>1175VCM-3</b>
1 3/4"	3 1/2" x 8"	<b>1176</b>	----	----
1 3/4" - 1 7/8"	3 1/2" x 9"	<b>1176V</b>	<b>1176VSP</b>	----

Chevy 18° Available

Bolts and Gaskets included

\* = 604 Crate Motor

\*CM2 = 602 Crate Motor

Temporary non-high temperature paint

## Small Block Chevy

Fits most chassis

TUBE DIAMETER	COLLECTOR DIA./LENGTH	STANDARD CHEVY #	*CRATE MOTOR #
1 5/8"	3" x 8"	<b>171</b>	<b>171CM2</b>
1 5/8" - 1 3/4"	3" x 8"	<b>171V-3</b>	<b>171VCM-3</b>
1 3/4"	3 1/2" x 8"	<b>172</b>	----
1 3/4" - 1 7/8"	3 1/2" x 9"	<b>172V</b>	----
1 7/8"	3 1/2" x 9"	<b>173</b>	----

Bolts and Gaskets included

\* = 604 Crate Motor

\*CM2 = 602 Crate Motor



## Modified Long-Tube Design

Fits American Made, Billsbuilt, GRT, \*LB Lonnie Robins, Ruhlman- \*W- IROC- \*F- Bandit, LG2, MB Customs- \*G- Sidebiter

TUBE DIAMETER	COLLECTOR DIA./LENGTH	STANDARD CHEVY #	*CRATE MOTOR #	SPREAD PORT	18° CHEVY
1 1/2" - 1 3/4" - 1 7/8"	3" x 9"	-----	1154LBV23CM-3	-----	-----
1 5/8"	3" x 8"	1155LB	1155LBCM2	-----	-----
1 5/8" - 1 3/4"	3" x 8"	1155LBV-3	1155LBVCM-3	-----	-----
1 5/8" - 1 3/4" - 1 7/8"	3" x 9"	1155LBV3-3	1155LBV3CM-3	-----	-----
1 3/4"	3 1/2" x 8"	1156LB	1156LBCM	-----	-----
1 3/4" - 1 7/8"	3 1/2" x 9"	1156LBV	1156LBVCM	1156LBVSP	-----

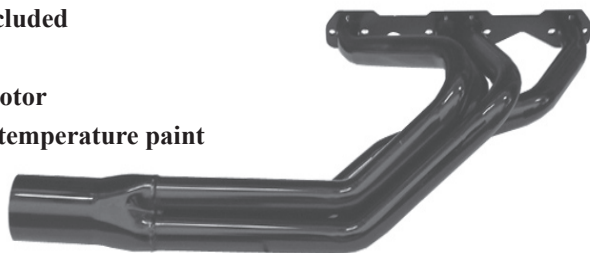

Bolts and Gaskets included

\* = 604 Crate Motor

\*CM2 = 602 Crate Motor

Temporary non-high temperature paint

\*W = 1 1/2" Up Right Side

\*F = 1" Farther Out Right Side

\*G = 2" Farther Out Right Side

## Modified Long-Tube Design

Fits Beakbuilt, Larry Shaw, Sidebitter, Taylor

TUBE DIAMETER	COLLECTOR DIA./LENGTH	STANDARD CHEVY #	*CRATE MOTOR #	SPREAD PORT	18° CHEVY
1 1/2" - 1 3/4" - 1 7/8"	3" x 9"	-----	1154LV23CM-3	-----	-----
1 5/8"	3" x 8"	1155L	1155LCM2	-----	-----
1 5/8" - 1 3/4"	3" x 8"	1155LV-3	1155LVCM-3	-----	-----
1 5/8" - 1 3/4" - 1 7/8"	3" x 9"	1155LV3-3	1155LV3CM-3	-----	-----
1 3/4"	3 1/2" x 8"	1156L	1156LCM	-----	-----
1 3/4" - 1 7/8"	3 1/2" x 9"	1156LV	1156LVCM	1156LVSP	1156LV18



Schoenfeld headers are not legal for sale or use on any pollution controlled vehicle intended for street or highway use.

Tractor/Derby  
Dirt Mod.  
Crossover  
Drag 4 Cyl.  
Crossover  
Collectors  
180° Crossover  
Gaskets  
Street Stock  
Stock Clip  
Stock Flanges/Gaskets  
U & J Bends  
Chassis  
Y Pipes  
Dirt Late Model  
IMCA Mod.  
Turnouts & Extensions  
X  
Sprint  
Misc.  
Midget  
Elbow Applications  
Chassis Applications  
Mufflers

## Modified Long-Tube Design

Longer primaries for maximum torque and horsepower

Fits Harris, Hoffman chassis

TUBE DIAMETER	COLLECTOR DIA./LENGTH	STANDARD CHEVY #	*CRATE MOTOR #	SPREAD PORT	18° CHEVY
1 5/8"	3" x 8"	<b>1101</b>	<b>1101CM2</b>	----	----
1 5/8" - 1 3/4"	3" x 8"	<b>1101V-3</b>	<b>1101VCM-3</b>	----	----
1 5/8" - 1 3/4" - 1 7/8"	3" x 8"	<b>1101V3-3</b>	<b>1101V3CM-3</b>	----	----
1 3/4"	3 1/2" x 8"	<b>1102</b>	<b>1102CM</b>	----	----
1 3/4" - 1 7/8"	3 1/2" x 9"	<b>1102V</b>	<b>1102VCM</b>	<b>1102VSP</b>	<b>1102V18</b>



Bolts and Gaskets included

\* = 604 Crate Motor

\*CM2 = 602 Crate Motor

Temporary non-high temperature paint



**NEW!**

## Modified Headers

**NEW!**

Longer primaries for maximum torque and horsepower

Fits Rage, Harris chassis (2016 and up)- \*W- Elite, Longhorn, Razor

TUBE DIAMETER	COLLECTOR DIA./LENGTH	STANDARD CHEVY #	*CRATE MOTOR #	SPREAD PORT	18° CHEVY
1 1/2" - 1 3/4" - 1 7/8"	3" x 9"	----	<b>1130V23CM-3</b>	----	----
1 5/8"	3" x 8"	<b>1131</b>	<b>1131CM2</b>	----	----
1 5/8" - 1 3/4"	3" x 8"	<b>1131V-3</b>	<b>1131VCM-3</b>	----	----
1 5/8" - 1 3/4" - 1 7/8"	3" x 9"	<b>1131V3-3</b>	<b>1131V3CM-3</b>	----	----
1 3/4" - 1 7/8"	3 1/2" x 9"	<b>1132V</b>	----	<b>1132VSP</b>	<b>1132V18</b>



Bolts and Gaskets included

\* = 604 Crate Motor

\*CM2 = 602 Crate Motor

Temporary non-high temperature paint

\*W = 1 1/2" Up Right Side

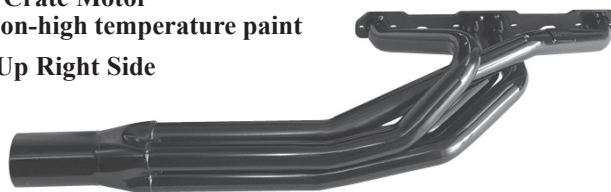

Tractor/Derby  
Dirt Mod.  
4 Cyl.  
Drag  
Collectors  
180° Crossover  
Flanges/Gaskets  
Stock Clip  
Street Stock  
U & J Bends  
Chassis  
X & Y Pipes  
IMCA Mod.  
Turnouts & Extensions  
Dirt Late Model  
Sprint  
Misc.  
Midget  
Elbow Applications  
Chassis Applications  
Mufflers



## *Ajustable Modified Headers* Small Block Chevy

TUBE DIAMETER	COLLECTOR DIA./LENGTH	FLANGE	L-STYLE 3 R-STYLE 8	L-STYLE 6 R-STYLE 8	L-STYLE 9 R-STYLE 8	L-STYLE 9H R-STYLE 8
1 1/2" - 1 5/8"	3" x 8"	STANDARD	<b>160-38</b>	<b>160-68</b>	<b>160-98</b>	<b>160-98H</b>
1 5/8" - 1 3/4"	3" x 8"	STANDARD	<b>161-38</b>	<b>161-68</b>	<b>161-98</b>	<b>161-98H</b>
1 3/4" - 1 7/8"	3 1/2" x 9"	STANDARD	<b>162-38</b>	<b>162-68</b>	<b>162-98</b>	<b>162-98H</b>
1 3/4" - 1 7/8"	3 1/2" x 9"	SPRD PORT	<b>162-38SP</b>	<b>162-68SP</b>	<b>162-98SP</b>	<b>162-98HSP</b>
1 3/4" 1 7/8"	3 1/2" x 9"	18° CHEVY	<b>162-38-18</b>	<b>162-68-18</b>	<b>162-98-18</b>	<b>162-98H-18</b>
1 7/8" - 2"	3 1/2" x 9"	STANDARD	<b>163-38</b>	<b>163-68</b>	<b>163-98</b>	<b>163-98H</b>

Bolts and Gaskets included

## Small Block Ford

TUBE DIAMETER	COLLECTOR DIA./LENGTH	FLANGE	L-STYLE 3 R-STYLE 8	L-STYLE 6 R-STYLE 8	L-STYLE 9 R-STYLE 8	L-STYLE 9H R-STYLE 8
1 5/8" - 1 3/4"	3" x 8"	WINDSOR	<b>361-38</b>	<b>361-68</b>	<b>361-98</b>	<b>361-98H</b>
1 3/4" - 1 7/8"	3 1/2" x 9"	WINDSOR	<b>362-38</b>	<b>362-68</b>	<b>362-98</b>	<b>362-98H</b>
1 5/8" - 1 3/4"	3" x 8"	*DART/"N"	<b>*361-38N</b>	<b>*361-68N</b>	<b>*361-98N</b>	<b>*361-98HN</b>
1 3/4" - 1 7/8"	3 1/2" x 9"	*DART/"N"	<b>*362-38N</b>	<b>*362-68N</b>	<b>*362-98N</b>	<b>*362-98HN</b>
1 3/4" - 1 7/8"	3 1/2" x 9"	CLEVELAND	<b>562-38</b>	<b>562-68</b>	<b>562-98</b>	<b>562-98H</b>
1 3/4" - 1 7/8"	3 1/2" x 9"	SVO (ALUM.)	<b>662-38</b>	<b>662-68</b>	<b>662-98</b>	<b>662-98H</b>

Specify for 4 barrel Cleveland Flange

\*Fits the wide Dart bolt pattern and Sportsman "N" head

Available for Edelbrock

## Small Block Chevy

TUBE DIAMETER	COLLECTOR DIA./LENGTH	STANDARD CHEVY #	*CRATE MOTOR #	SPREAD PORT #	CHEVY 18° #
1 1/2"	3" x 8"	<b>160</b>	----	----	----
1 5/8"	3" x 8"	<b>161</b>	<b>161CM2</b>	----	----
1 5/8" - 1 3/4"	3" x 8"	<b>161V-3</b>	<b>161VCM-3</b>	----	----
1 3/4"	3 1/2" x 8"	<b>162</b>	<b>162CM</b>	----	----
1 7/8"	3 1/2" x 9"	<b>163</b>	----	<b>163SP</b>	<b>163-18</b>

Bolts and Gaskets included

\* = 604 Crate Motor

\*CM2 = 602 Crate Motor

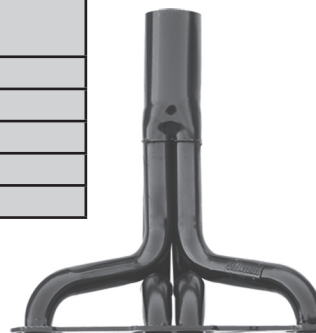

## Small Block Ford

Bolts and Gaskets included

TUBE DIAMETER	COLLECTOR DIA./LENGTH	WINDSOR #	DART/"N" SPORTSMAN #
1 5/8"	3" x 8"	<b>361</b>	<b>361N</b>
1 3/4"	3 1/2" x 8"	<b>362</b>	<b>362N</b>

(Available for Edelbrock)

TUBE DIAMETER	COLLECTOR DIA./LENGTH	CLEVELAND 2 BARREL #	CLEVELAND 4 BARREL #
1 3/4"	3 1/2" x 8"	<b>562</b>	----
1 3/4"	3 1/2" x 8"	----	<b>562-4B</b>

Gaskets not included or available for Cleveland



Chassis Applications | Midget | Sprint | Dirt Late Model | IMCA Mod. | Chassis | Street Stock | Stock Clip | 180° Crossover | Crossover | Tractor/Derby | Mufflers | Elbow Applications | Misc. | Turnouts & Extensions | X & Y Pipes | U & J Bends | Flanges/Gaskets | Collectors | Drag | 4 Cyl. | Dirt Mod.



## Ford Modified Long-Tube Design

Longer primaries for maximum torque and horsepower

Fits Dirtworks and most other Chassis

TUBE DIAMETER	COLLECTOR DIA./LENGTH	WINDSOR #	DART/ "N" HEAD #
1 5/8" - 1 3/4"	3 1/2" x 8"	<b>3185V</b>	<b>*3185VN</b>
1 5/8" - 1 3/4"	3" x 8"	<b>3185V-3</b>	<b>*3185VN-3</b>
1 3/4"	3 1/2" x 8"	<b>3186</b>	<b>*3186N</b>
1 3/4" - 1 7/8"	3 1/2" x 9"	<b>3186V</b>	<b>*3186VN</b>

\*Fits wide Dart bolt pattern and "N" head

Bolts and Gaskets included

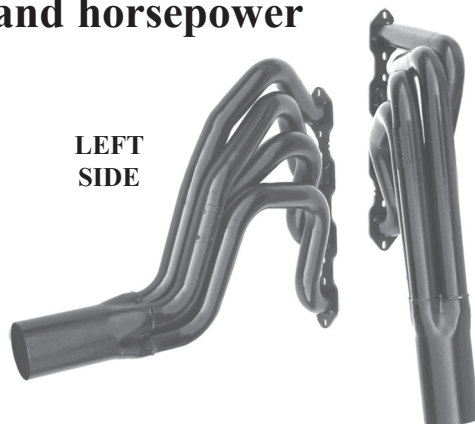

## Chevy Modified Short Tube Design

Fits BMS, Hughes, Larry Shaw, Razor, TRE



TUBE DIAMETER	COLLECTOR DIA./LENGTH	STANDARD CHEVY #	*CRATE MOTOR #
1 5/8"	3" x 8"	<b>1145</b>	<b>1145CM2</b>
1 5/8" - 1 3/4"	3 1/2" x 8"	<b>1145V</b>	<b>1145VCM</b>
1 5/8" - 1 3/4"	3" x 8"	<b>1145V-3</b>	<b>1145VCM-3</b>
1 3/4"	3 1/2" x 8"	<b>1146</b>	<b>1146CM</b>
1 3/4" - 1 7/8"	3 1/2" x 9"	<b>1146V</b>	<b>1146VCM</b>



Available right side mirror image of left side

Bolts and Gaskets included  
 Available Spread Port and 18°  
 \* = 604 Crate Motor  
 \*CM2 = 602 Crate Motor  
 Temporary non-high temperature paint

## Modified Long Tube Design

Fits Hughes, J Car, Kraft, Rage, TRE

TUBE DIAMETER	COLLECTOR DIA./LENGTH	STANDARD CHEVY #	*CRATE MOTOR #	SPREAD PORT	18° CHEVY
1 5/8"	3" x 8"	<b>1165</b>	<b>1165CM2</b>	----	----
1 5/8" - 1 3/4"	3 1/2" x 8"	<b>1165V</b>	<b>1165VCM</b>	----	----
1 5/8" - 1 3/4"	3" x 8"	<b>1165V-3</b>	<b>1165VCM-3</b>	----	----
1 3/4"	3 1/2" x 8"	<b>1166</b>	<b>1166CM</b>	----	----
1 3/4" - 1 7/8"	3 1/2" x 9"	<b>1166V</b>	<b>1166VCM</b>	<b>1166VSP</b>	<b>1166V18</b>

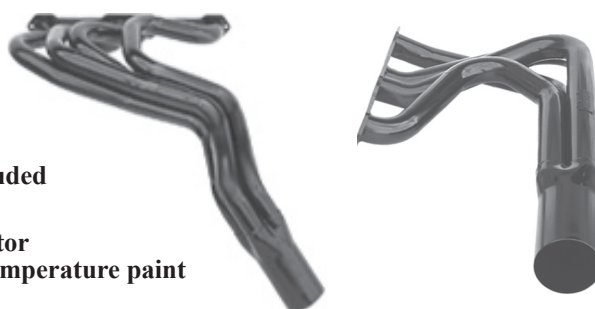

Bolts and Gaskets included  
 \* = 604 Crate Motor  
 \*CM2 = 602 Crate Motor  
 Temporary non-high temperature paint



## SB Chevy Modified Tri-Y

4 Into 2 Into 1 Tube Configuration for Increased Torque  
Fits Hoffman, Impressive, Bob Pierce, Victory, J Car, Harris

TUBE DIAMETER	COLLECTOR DIA.	STANDARD CHEVY #
1 5/8" - 1 3/4"	3"	<b>1185VY</b>
1 3/4" - 1 7/8"	3 1/2"	<b>1186VY</b>

Fits Hoffman, Bob Pierce, GRT, TRE, Buzzard

TUBE DIAMETER	COLLECTOR DIA.	STANDARD CHEVY #
1 5/8" - 1 3/4"	3"	<b>1185VYH</b>
1 3/4" - 1 7/8"	3 1/2"	<b>1186VYH</b>

Fits Larry Shaw, J-Car, Jet, Elite

TUBE DIAMETER	COLLECTOR DIA.	STANDARD CHEVY #
1 5/8" - 1 3/4"	3"	<b>1195VY</b>
1 3/4" - 1 7/8"	3 1/2"	<b>1196VY</b>

Spread Port & 18° Available for 1 3/4"  
Comes With 5/16" Flange  
Temporary non-high temperature paint

## SB Chevy Modified Tri-Y

Fits Bandit, Elite, GRT, Impressive, IROC, MB Customs, Shaw

TUBE DIAMETER	COLLECTOR DIA.	STANDARD CHEVY #
1 3/4" - 1 7/8"	3 1/2"	<b>1152LVYZ</b>
1 3/4" - 1 7/8" - 2"	3 1/2"	<b>1152LV3YZ</b>

Spread Port & 18° Available for 1 3/4"  
Comes With 5/16" Flange  
Temporary non-high temperature paint  
Big Bend Die - 4" Radius Bends

## SB Chevy Modified Tri-Y

4 Into 2 Into 1 Tube Configuration for Increased Torque

Fits Beak Built, Leathal, LG2

Big Bend Die - 4" Radius Bends

TUBE DIAMETER	COLLECTOR DIA.	STANDARD CHEVY #	18° CHEVY #
1 3/4" - 2"	3 1/2"	<b>1142LV2YZ</b>	----
1 3/4" - 2"	3 1/2"	-----	<b>1142LV2YZ18</b>

Tractor/Derby  
Dirt Mod.  
Crossover  
Drag 4 Cyl.  
Crossover  
Collectors  
180° Crossover  
Flanges/Gaskets  
Stock Clip  
Street Stock  
U & J Bends  
Chassis  
X & Y Pipes  
Turnouts & Extensions  
Misc.  
Sprint  
Elbow Applications  
Midget  
Mufflers  
Chassis Applications  
Dirt Late Model  
IMCA Mod.  
Chassis  
X & Y Pipes  
Turnouts & Extensions  
Misc.  
Sprint  
Elbow Applications  
Midget  
Mufflers

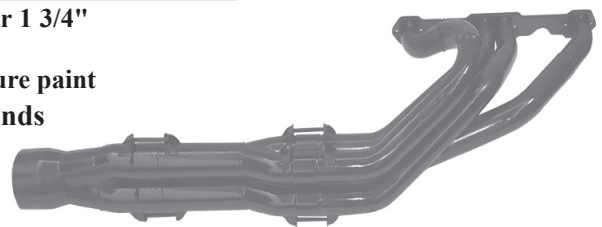
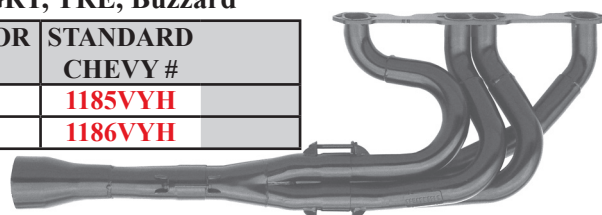
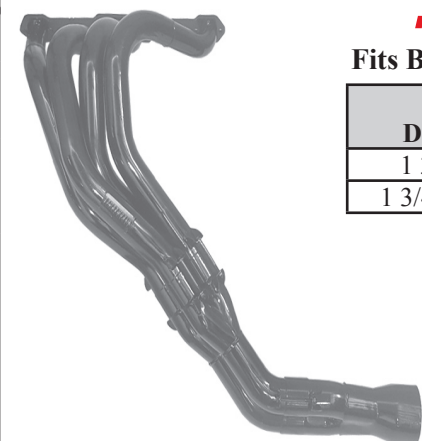
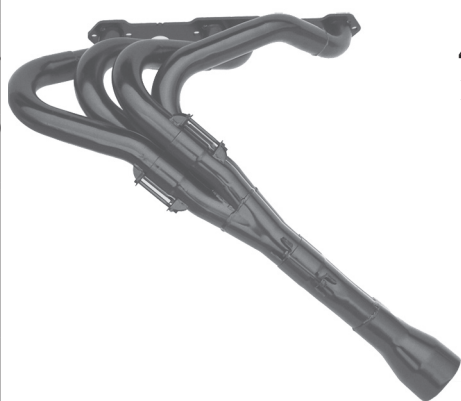

## Long Primary Dirt Late Model Tri-Y Inside Frame Right Side

4 Into 2 Into 1 Tube  
Configuration for  
Increased Torque

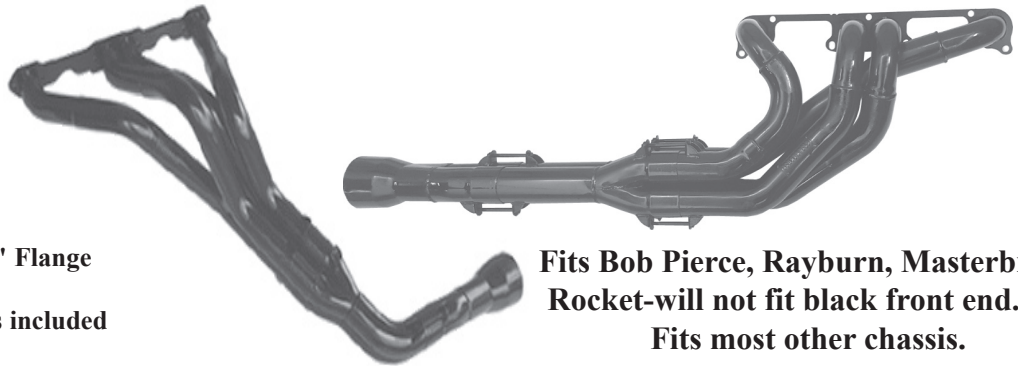

Comes With 5/16" Flange

Bolts and Gaskets included

Fits Bob Pierce, Rayburn, Masterbilt,  
Rocket-will not fit black front end.  
Fits most other chassis.

### Available Brodix Spec. Head

TUBE DIAMETER	COLL. DIA.	STANDARD CHEVY #	SPREAD PORT #	13°, 15°, 16° CHEVY 18° #
1 5/8" - 1 3/4"	3"	14160LVYIF	----	----
1 5/8" - 1 3/4" - 1 7/8"	3 1/2"	14160LV3YIF	----	----
1 3/4" - 1 7/8"	3 1/2"	14260LVYIF	14260LVYIFSP	14260LVYIF18
1 3/4" - 1 7/8" - 2"	3 1/2"	14260LV3YIF	14260LV3YIFSP	14260LV3YIF18
1 7/8" - 2"	3 1/2"	14360LVYIF	14360LVYIFSP	14360LVYIF18

### Available Crate Motor

## Long Primary Dirt Late Model Tri-Y

4 Into 2 Into 1 Tube  
Configuration for  
Increased Torque



Fits Bob Pierce, Rayburn, Masterbilt,  
Rocket-will not fit black front end.  
Fits most other chassis.

Comes With 5/16" Flange

Bolts and Gaskets included

### Available Brodix Spec. Head

TUBE DIAMETER	COLL. DIA.	STANDARD CHEVY #	SPREAD PORT #	13°, 15°, 16° CHEVY 18° #	SB2 CHEVY #
1 5/8" - 1 3/4"	3"	14160LVY	----	----	----
1 5/8" - 1 3/4" - 1 7/8"	3 1/2"	14160LV3Y	----	----	----
1 3/4" - 1 7/8"	3 1/2"	14260LVY	14260LVYSP	14260LVY18	14260LVYSB2
1 3/4" - 1 7/8" - 2"	3 1/2"	14260LV3Y	14260LV3YSP	14260LV3Y18	14260LV3YSB2
1 7/8" - 2"	3 1/2"	14360LVY	14360LVYSP	14360LVY18	14360LVYSB2

### Available Crate Motor

### 4-7 Cam Swap

TUBE DIAMETER	COLL. DIA.	STANDARD CHEVY #	SPREAD PORT #	13°, 15°, 16° CHEVY 18° #	SB2 CHEVY #
1 5/8" - 1 3/4"	3"	14167LVY	----	----	----
1 5/8" - 1 3/4" - 1 7/8"	3 1/2"	14167LV3Y	----	----	----
1 3/4" - 1 7/8"	3 1/2"	14267LVY	14267LVYSP	14267LVY18	14267LVYSB2
1 3/4" - 1 7/8" - 2"	3 1/2"	14267LV3Y	14267LV3YSP	14267LV3Y18	14267LV3YSB2
1 7/8" - 2"	3 1/2"	14367LVY	14367LVYSP	14367LVY18	14367LVYSB2

### Available Crate Motor



## **Dirt Late Model Long Tube Inside Frame Right Side**

24" - Rocket, 2012 Barry Wright  
 26" - GRT, Bob Pierce, Barry Wright, Bernheisel, Larry Shaw, Longhorn, Mastersbuilt, Rayburn and Warrior.

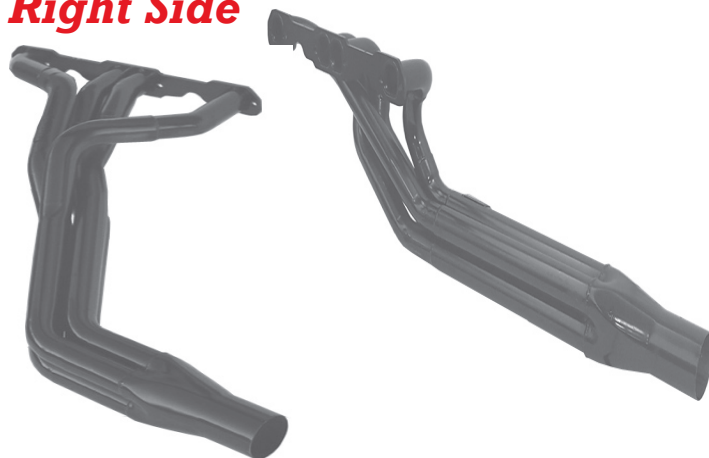

I/S - From head surface to inside left collector  
 Temporary non-high temperature paint  
 \*CM2 = 602 Crate Motor  
 \* = 604 Crate Motor

TUBE DIAMETER	COLLECTOR DIA./LENGTH	*CRATE MOTOR # 24" TO I/S COLL.	*CRATE MOTOR # 26" TO I/S COLL.	*CRATE MOTOR # 28" TO I/S COLL.
1 5/8" - 1 3/4"	3 1/2" x 8"	<b>181-4IFLVCM2</b>	<b>181-6IFLVCM2</b>	<b>181-8IFLVCM2</b>
1 5/8" - 1 3/4"	3" x 8"	<b>181-4IFLVCM2-3</b>	<b>181-6IFLVCM2-3</b>	<b>181-8IFLVCM2-3</b>
1 5/8" - 1 3/4" - 1 7/8"	3" x 8"	<b>181-4IFLV3CM-3</b>	<b>181-6IFLV3CM-3</b>	<b>181-8IFLV3CM-3</b>
1 3/4" - 1 7/8"	3 1/2" x 9"	<b>182-4IFLVCM</b>	<b>182-6IFLVCM</b>	<b>182-8IFLVCM</b>
1 3/4" - 1 7/8"	3" x 8"	<b>182-4IFLVCM-3</b>	<b>182-6IFLVCM-3</b>	<b>182-8IFLVCM-3</b>

## **Dirt Late Model Long Tube**

24" - Rocket, 2012 Barry Wright  
 26" - GRT, Bob Pierce, Barry Wright, Bernheisel, Larry Shaw, Longhorn, Mastersbuilt, Rayburn and Warrior.



I/S - From head surface to inside left collector  
 \* = 604 Crate Motor  
 \*CM2 = 602 Crate Motor

TUBE DIAMETER	COLLECTOR DIA./LENGTH	*CRATE MOTOR # 24" TO I/S COLL.	*CRATE MOTOR # 26" TO I/S COLL.	*CRATE MOTOR # 28" TO I/S COLL.
1 5/8" - 1 3/4"	3 1/2" x 8"	<b>181-406LVGCM2</b>	<b>181-606LVGCM2</b>	<b>181-806LVGCM2</b>
1 5/8" - 1 3/4"	3" x 8"	<b>181-406LVGCM2-3</b>	<b>181-606LVGCM2-3</b>	<b>181-806LVGCM2-3</b>
1 5/8" - 1 3/4" - 1 7/8"	3" x 8"	<b>181-406LV3GCM-3</b>	<b>181-606LV3GCM-3</b>	<b>181-806LV3GCM-3</b>
1 3/4" - 1 7/8"	3 1/2" x 9"	<b>182-406LVGCM</b>	<b>182-606LVGCM</b>	<b>182-806LVGCM</b>
1 3/4" - 1 7/8"	3" x 8"	<b>182-406LVGCM-3</b>	<b>182-606LVGCM-3</b>	<b>182-806LVGCM-3</b>

TUBE DIAMETER	COLLECTOR DIA./LENGTH	STANDARD CHEVY # 24" TO I/S COLL.	STANDARD CHEVY # 26" TO I/S COLL.	STANDARD CHEVY # 28" TO I/S COLL.
1 5/8" - 1 3/4"	3 1/2" x 8"	<b>181-406LVG</b>	<b>181-606LVG</b>	<b>181-806LVG</b>
1 5/8" - 1 3/4"	3" x 8"	<b>181-406LVG-3</b>	<b>181-606LVG-3</b>	<b>181-806LVG-3</b>
1 5/8" - 1 3/4" - 1 7/8"	3" x 8"	<b>181-406LV3G-3</b>	<b>181-606LV3G-3</b>	<b>181-806LV3G-3</b>
1 3/4" - 1 7/8"	3 1/2" x 9"	<b>182-406LVG</b>	<b>182-606LVG</b>	<b>182-806LVG</b>
1 3/4" - 1 7/8"	3 1/2" x 9"	<b>*182-406LVGSP</b>	<b>*182-606LVGSP</b>	<b>*182-806LVGSP</b>
1 3/4" - 1 7/8"	3" x 8"	<b>182-406LVG-3</b>	<b>182-606LVG-3</b>	<b>182-806LVG-3</b>
1 3/4" - 1 7/8"	3" x 8"	<b>*182-406LVGSP-3</b>	<b>*182-606LVGSP-3</b>	<b>*182-806LVGSP-3</b>

Chassis Applications | Midget Sprint | Dirt Late Model | IMCA Mod. | Chassis | Street Stock | Stock Clip | 180° Crossover | Crossover | Tractor/Derby | Misc. | Turnouts & Extensions | X & Y Pipes | U & J Bends | Flanges/Gaskets | Collectors | Drag | 4 Cyl. | Dirt Mod.

## Chevy Dirt Late Model

Fits GRT, Stinger, TNT, Bob Pierce, Barry Wright, Bullitt, Larry Shaw, Raider, Warrior and Rayburn



LEFT SIDE

\* = 604 Crate Motor  
Temporary non-high temperature paint

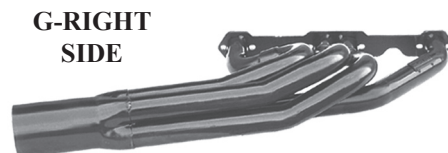

G-RIGHT SIDE

### 605 OFF-SET

Available Brodix Spec. Head

TUBE DIAMETER	COLL. DIA. LENGTH	STANDARD CHEVY #	*CRATE MOTOR #	SPREAD PORT #	13°, 15°, 16° CHEVY 18° #	SB2 CHEVY #
1 5/8" - 1 3/4"	3 1/2" x 8"	141-605LVG	141-605LVGCM	----	----	----
1 5/8" - 1 3/4"	3" x 8"	141-605LVG-3	141-605LVGCM-3	----	----	----
1 3/4"	3 1/2" x 8"	142-605LG	----	----	----	----
1 3/4" - 1 7/8"	3 1/2" x 9"	142-605LVG	142-605LVGCM	142-605LVGSP	142-605LVG18	142-605LVGSB2
1 7/8" - 2"	3 1/2" x 9"	143-605LVG	----	143-605LVGSP	143-605LVG18	143-605LVGSB2

### Fits Mastersbilt, Warrior

### 505 OFF-SET

Available Brodix Spec. Head

TUBE DIAMETER	COLL. DIA. LENGTH	STANDARD CHEVY #	*CRATE MOTOR	SPREAD PORT #	13°, 15°, 16° CHEVY 18° #	SB2 CHEVY #
1 5/8" - 1 3/4"	3 1/2" x 8"	141-505LVG	141-505LVGCM	----	----	----
1 5/8" - 1 3/4"	3" x 8"	141-505LVG-3	141-505LVGCM-3	----	----	----
1 3/4"	3 1/2" x 8"	142-505LG	----	----	----	----
1 3/4" - 1 7/8"	3 1/2" x 9"	142-505LVG	142-505LVGCM	142-505LVGSP	142-505LVG18	142-505LVGSB2
1 7/8" - 2"	3 1/2" x 9"	143-505LVG	----	143-505LVGSP	143-505LVG18	143-505LVGSB2



LEFT SIDE

## Chevy Dirt Late Model

\* = 604 Crate Motor



RIGHT SIDE

### Fits Rocket, Bernheisel

### 525 OFF-SET

Available Brodix Spec. Head

TUBE DIAMETER	COLL. DIA. LENGTH	STANDARD CHEVY #	*CRATE MOTOR #	SPREAD PORT #	13°, 15°, 16° CHEVY 18° #	SB2 CHEVY #
1 5/8" - 1 3/4"	3 1/2" x 8"	141-525LV	----	----	----	----
1 5/8" - 1 3/4"	3" x 8"	141-525LV-3	141-525LVCM-3	----	----	----
1 3/4"	3 1/2" x 8"	142-525L	----	----	----	----
1 3/4" - 1 7/8"	3 1/2" x 9"	142-525LV	142-525LVCM	142-525LVSP	142-525LV18	142-525LVSB2
1 7/8" - 2"	3 1/2" x 9"	143-525LV	----	143-525LVSP	143-525LV18	143-525LVSB2



## Chevy LS1- LS7 Tri-Y Dirt Late Model

TUBE DIAMETER	COLLECTOR DIA./LENGTH	LS1 - LS7 CHEVY #
1 3/4" - 1 7/8"	3 1/2" x 9"	<b>14260LVYLS3</b>



Fits Bob Pierce, GRT, Rayburn, Masterbuilt, Larry Shaw, Rocket.  
Fits most other chassis.  
Temporary non-high temperature paint

Ford Tri-Y's available with R-45, Yates C3/D3, Dart N heads.

## Ford Dirt Late Model

TUBE DIAMETER	COLLECTOR DIA./LENGTH	289-302-351 WINDSOR #	289-302-351 WINDSOR #	289-302-351 WINDSOR #
1 5/8" - 1 3/4"	3 1/2" x 8"	<b>341-605LVG</b>	<b>341-525LV</b>	<b>341-505LVG</b>
1 5/8" - 1 3/4"	3" x 8"	<b>341-605LVG-3</b>	<b>341-525LV-3</b>	<b>341-505LVG-3</b>
1 3/4"	3 1/2" x 8"	<b>342-605LG</b>	<b>342-525L</b>	<b>342-505LG</b>
1 3/4" - 1 7/8"	3 1/2" x 9"	<b>342-605LVG</b>	<b>342-525LV</b>	<b>342-505LVG</b>



Left Side

(Also available for wide Dart bolt pattern and Sportsman "N" Head)  
Temporary non-high temperature paint

G-RIGHT SIDE



525-RIGHT SIDE



## Chevy Boat/Marine OVER-THE-TRANSON HEADERS

TUBE DIAMETER	COLLECTOR DIA./LENGTH	STANDARD CHEVY #	SPREAD PORT
1 5/8" - 1 3/4"	3 1/2" x 13"	<b>1092LV</b>	----
1 5/8" - 1 3/4"	3" x 13"	<b>1092LV-3</b>	----
1 3/4" - 1 7/8"	3 1/2" x 13"	<b>1094LV</b>	----
1 7/8" - 2"	3 1/2" x 13"	<b>1095LV</b>	----
1 3/4" - 1 7/8"	3 1/2" x 13"	----	<b>1094LVSP</b>
1 7/8" - 2"	3 1/2" x 13"	----	<b>1095LVSP</b>



Temporary non-high temperature paint

Bolts and Gaskets included

Tractor/Derby  
Dirt Mod.  
Crossover  
Drag 4 Cyl.  
Crossover  
Collectors  
180° Crossover  
Flanges/Gaskets  
Stock Clip  
Street Stock  
U & J Bends  
Chassis  
IMCA Mod.  
X & Y Pipes  
Turnouts & Extensions  
Dirt Late Model  
Misc.  
Midget  
Elbow Applications  
Chassis Applications  
Mufflers

## Chevy Sprint Car Headers Big Bend Die Radius

Available with CNC laser cut flanges to fit:  
Brodix 18°, Standard Chevy 18°, Allen Johnson,  
Pontiac 867, Stahl.

**Big Bend Die - 4" Radius Bends**

TUBE DIAMETER	COLLECTOR DIA./LENGTH	STANDARD CHEVY #	SPREAD PORT/D.N #	ALL PRO GB 2300/2400 #
1 7/8" - 2"	3 1/2" x 13"	1055LVZ	1055LVDNZ	1055LVAPZ
2"	3 1/2" x 13"	----	1056LDNZ	1056LAPZ



**Bolts and Gaskets included**  
Armor 400 Gaskets available for D.N & All Pro  
Temporary non-high temperature paint  
Welded to clear 4 inches from head to inside of header.

### LS1

TUBE DIAMETER	COLLECTOR DIA./LENGTH	LS1 #
1 5/8" - 1 3/4"	3 1/2" x 13"	1022LVLS1
1 3/4"	3 1/2" x 13"	1024L-LS1
1 3/4" - 1 7/8"	3 1/2" x 13"	1024LVLS1

### SB2

TUBE DIAMETER	COLLECTOR DIA./LENGTH	SB2 CHEVY #
1 3/4" - 1 7/8"	3 1/2" x 13"	1014LVSB2
1 7/8" - 2"	3 1/2" x 13"	1015LVSB2

## Dyno/Sprint

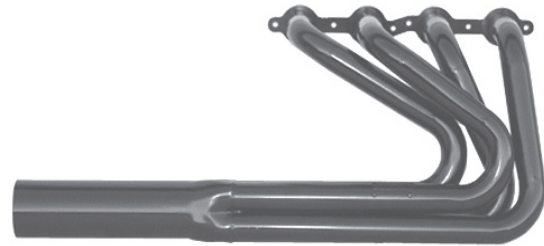

Comes With 5/16" Flange  
Bolts and Gaskets included  
Temporary non-high temperature paint

### Big Block Chevy

TUBE DIAMETER	COLLECTOR DIA./LENGTH	BIG BLOCK #
2"	3 1/2" x 13"	2016A
2"	4" x 13"	2016
2 1/8"	4" x 13"	2017
2 1/4"	4" x 13"	2018
2 3/8"	4 1/2" x 13"	2019
2 3/8"	5" x 13"	2019-5

### Big Block Ford

TUBE DIAMETER	COLLECTOR DIA./LENGTH	429-460 FORD #
2"	4" x 13"	6016
2 1/8"	4" x 13"	6017

## Dyno/Sprint



Temporary non-high temperature paint  
Bolts and Gaskets included  
Comes With 5/16" Flange



## Chevy Sprint Car Headers

**Improved** to fit raised rail. 32" Length primaries - 18 ga. Tubing.  
Removes over 200° of bend compared to normal header to increase flow.

Available with CNC laser cut flanges to fit:  
Brodix 18°, Standard Chevy 18°, Allen Johnson,  
Pontiac 867, Stahl.

Welded to clear 4 inches from  
head to inside of header.

TUBE DIAMETER	COLLECTOR DIA./LENGTH	STANDARD CHEVY #	*CRATE MOTOR	SPREAD PORT/D.N #	ALL PRO GB 2300/2400 #
1 5/8"	3" x 13"	<b>1052L</b>	<b>1052LCM2</b>	----	----
1 5/8" - 1 3/4"	3 1/2" x 13"	<b>1052LV</b>	----	----	----
1 5/8" - 1 3/4"	3" x 13"	<b>1052LV-3</b>	<b>1052LVCM-3</b>	----	----
1 3/4"	3 1/2" x 13"	<b>1054L</b>	----	----	----
1 3/4" - 1 7/8"	3 1/2" x 13"	<b>1054LV</b>	----	<b>1054LVSP</b>	----
1 7/8"	3 1/2" x 13"	<b>1055L</b>	----	<b>1055LDN</b>	<b>1055LAP</b>
1 7/8" - 2"	3 1/2" x 13"	<b>1055LV</b>	----	<b>1055LVDN</b>	<b>1055LVAP</b>
2"	3 1/2" x 13"	----	----	<b>1056LDN</b>	<b>1056LAP</b>



Straight tube Design

\* = 604 Crate Motor  
\*CM2 = 602 Crate Motor

Bolts and Gaskets included  
Armor 400 Gaskets available for D.N & All Pro  
Temporary non-high temperature paint

## Chevy Sprint Tri-Y Headers

4 Into 2 Into 1 Tube Configuration for Increased Torque

TUBE DIAMETER	COLLECTOR DIAMETER	STANDARD CHEVY #	SPREAD PORT/D.N #
1 5/8" - 1 3/4"	3"	<b>1062VY</b>	----
1 3/4" - 1 7/8"	3 1/2"	<b>1064VY</b>	<b>1064VYSP</b>
1 7/8" - 2"	3 1/2"	<b>1065VY</b>	<b>1065VYDN</b>

Standard Design

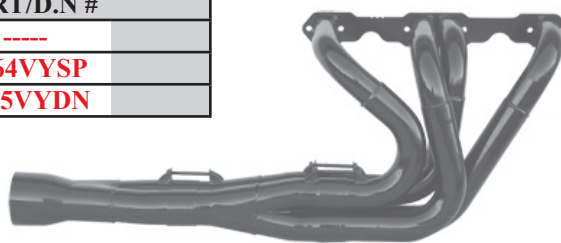

Bolts and Gaskets included  
Comes With 5/16" Flange  
Armor 400 Gaskets available for D.N & All Pro  
Temporary non-high temperature paint

TUBE DIAMETER	COLLECTOR DIAMETER	STANDARD CHEVY #	SPREAD PORT/D.N #
1 5/8" - 1 3/4"	3"	<b>1022VY</b>	----
1 3/4" - 1 7/8"	3 1/2"	<b>1024VY</b>	<b>1024VYSP</b>
1 7/8" - 2"	3 1/2"	<b>1025VY</b>	<b>1025VYDN</b>

Bolts and Gaskets included  
Comes With 5/16" Flange  
Armor 400 Gaskets available for D.N & All Pro

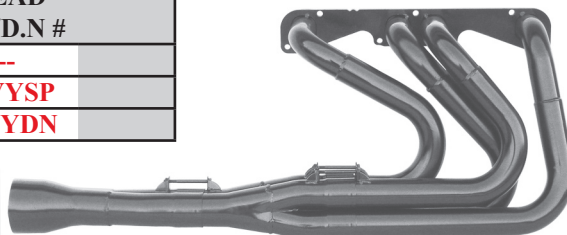

Forward Design

Tractor/Derby  
Dirt Mod.  
Crossover  
Drag 4 Cyl.  
Crossover  
Collectors  
180° Crossover  
Gaskets  
Stock Clip  
Flanges/Gaskets  
Street Stock  
U & J Bends  
Chassis  
X & Y Pipes  
IMCA Mod.  
Turnouts & Extensions  
Dirt Late Model  
Misc.  
Midget  
Elbow Applications  
Chassis Applications  
Mufflers



## Chevy Sprint Car Headers

Improved to fit raised rail. 32" Primaries - 18 ga. Tubing.  
Forward Design for additional muffler clearance

Cab Forward Design

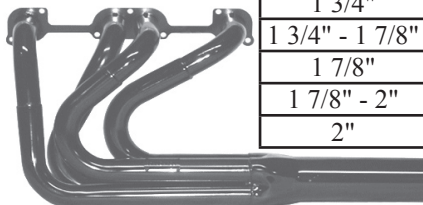

TUBE DIAMETER	COLLECTOR DIA./LENGTH	STANDARD CHEVY #	*CRATE MOTOR	SPREAD PORT/D.N #	ALL PRO GB23/24 #
1 1/2" - 1 5/8"	3" x 13"	1021LV		----	----
1 5/8"	3" x 13"	1022L	1022LCM2	----	----
1 5/8" - 1 3/4"	3" x 13"	1022LV-3	1022LVCM-3	----	----
1 3/4"	3 1/2" x 13"	1024L		----	----
1 3/4" - 1 7/8"	3 1/2" x 13"	1024LV		1024LVSP	1024LVAP
1 7/8"	3 1/2" x 13"	1025L		1025LDN	1025LAP
1 7/8" - 2"	3 1/2" x 13"	1025LV		1025LVDN	1025LVAP
2"	3 1/2" x 13"	----		1026LDN	1026LAP

\* = 604 Crate Motor  
\*CM2 = 602 Crate Motor

Armor 400 Gaskets available for D.N & All Pro Bolts and Gaskets included

### 32" Primaries - 18 ga. Tubing CNC Laser Cut flange

TUBE DIAMETER	COLLECTOR DIA./LENGTH	SPREAD PORT #
1 3/4" - 1 7/8"	3 1/2" x 13"	1014LVSP
1 7/8"	3 1/2" x 13"	1015LDN
1 7/8" - 2"	3 1/2" x 13"	1015LVDN
2"	3 1/2" x 13"	1016LDN

Standard Design

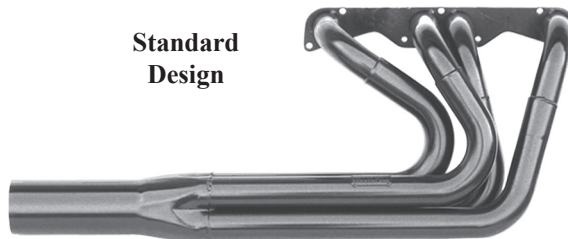

Available for All Pro & Brodix GB heads  
Welded to clear 4 inches from head to inside of header.  
Bolts and Gaskets included  
Armor 400 Gaskets available for D.N & All Pro

### 32" Primaries



Standard Design

TUBE DIAMETER	COLLECTOR DIA./LENGTH	STANDARD CHEVY #
1 1/2" - 1 5/8"	3" x 8"	1011LV
1 5/8"	3" x 8"	1012L
1 5/8" - 1 3/4"	3 1/2" x 8"	1012LV
1 5/8" - 1 3/4"	3" x 8"	1012LV-3
1 3/4"	3 1/2" x 8"	1014L
1 3/4" - 1 7/8"	3 1/2" x 9"	1014LV
1 7/8"	3 1/2" x 9"	1015L
1 7/8" - 2"	3 1/2" x 9"	1015LV

Bolts and Gaskets included

## Chevy Asphalt Sprint

TUBE DIAMETER	COLLECTOR DIA./LENGTH	SPREAD PORT/D.N #
1 3/4" - 1 7/8"	3 1/2" x 13"	1034LVSP
1 7/8" - 2"	3 1/2" x 13"	1035LVDN

Available for All Pro & Brodix GB heads  
Armor 400 Gaskets available for D.N & All Pro  
Bolts and Gaskets included



Tractor/Derby  
Dirt Mod.  
4 Cyl. Drag  
Crossovers  
180° Crossover Collectors  
Flanges/Gaskets  
Stock Clip  
Street Stock  
U & J Bends  
Chassis  
X & Y Pipes  
IMCA Mod.  
Turnouts & Extensions  
Dirt Late Model  
Sprint  
Midget  
Chassis Applications  
Elbow Applications  
Mufflers

## Mopar Sprint Car Headers

Straight tube design removes over 200° of bend compared to normal header to increase exhaust flow.

Straight tube Design

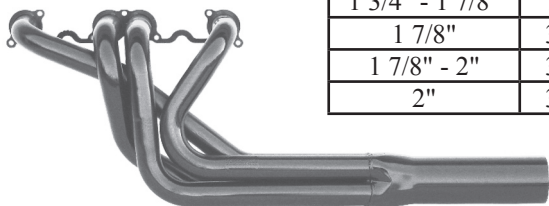

TUBE DIAMETER	COLLECTOR DIA./LENGTH	STANDARD MOPAR #	W-2 MOPAR #	W-9 MOPAR #
1 5/8"	3" x 13"	<b>4052L</b>	<b>4052LW2</b>	----
1 5/8" - 1 3/4"	3 1/2" x 13"	<b>4052LV</b>	<b>4052LVW2</b>	----
1 5/8" - 1 3/4"	3" x 13"	<b>4052LV-3</b>	<b>4052LVW2-3</b>	----
1 3/4"	3 1/2" x 13"	<b>4054L</b>	<b>4054LW2</b>	----
1 3/4" - 1 7/8"	3 1/2" x 13"	<b>4054LV</b>	<b>4054LVW2</b>	----
1 7/8"	3 1/2" x 13"	----	----	<b>4055LW9</b>
1 7/8" - 2"	3 1/2" x 13"	----	----	<b>4055LVW9</b>
2"	3 1/2" x 13"	----	----	<b>4056LW9</b>

Bolts and Gaskets included for small block standard Mopar  
Gaskets not included or available for W2, W9

### Forward Design for additional muffler clearance



Cab Forward Design

TUBE DIAMETER	COLLECTOR DIA./LENGTH	STANDARD MOPAR #	W-2 MOPAR #	W-9 MOPAR #
1 5/8"	3" x 13"	<b>4022L</b>	<b>4022LW2</b>	----
1 5/8" - 1 3/4"	3 1/2" x 13"	<b>4022LV</b>	<b>4022LVW2</b>	----
1 3/4"	3 1/2" x 13"	<b>4024L</b>	<b>4024LW2</b>	----
1 3/4" - 1 7/8"	3 1/2" x 13"	<b>4024LV</b>	<b>4024LVW2</b>	<b>4024LVW9</b>
1 7/8"	3 1/2" x 13"	----	----	<b>4025LW9</b>
1 7/8" - 2"	3 1/2" x 13"	----	----	<b>4025LVW9</b>
2"	3 1/2" x 13"	----	----	<b>4026LW9</b>

Bolts and Gaskets included for small block standard Mopar  
Gaskets not included or available for W2, W9  
Temporary non-high temperature paint

## Ford Sprint Car Header

### Forward Design for additional muffler clearance

TUBE DIAMETER	COLLECTOR DIA./LENGTH	289-302-351 WINDSOR #	DART/"N" SPORTSMAN #
1 5/8"	3" x 13"	<b>3022L</b>	<b>*3022LN</b>
1 5/8" - 1 3/4"	3 1/2" x 13"	<b>3022LV</b>	<b>*3022LVN</b>
1 3/4"	3 1/2" x 13"	<b>3024L</b>	<b>*3024LN</b>
1 3/4" - 1 7/8"	3 1/2" x 13"	<b>3024LV</b>	<b>*3024LVN</b>

\*Fits the wide Dart bolt pattern and Sportsman "N" head  
(Available for Edelbrock)

Cab Forward Design

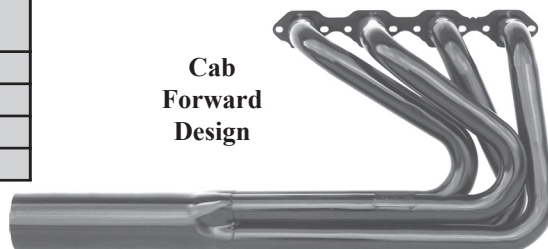

Chassis Applications Midget Sprint Dirt Late Model IMCA Mod. Chassis Street Stock Stock Clip 180° Crossover Crossover Tractor/Derby  
Mufflers Elbow Applications Misc. Turnouts & Extensions X & Y Pipes U & J Bends Flanges/Gaskets Collectors Drag 4 Cyl. Dirt Mod.

## Toyota Midget Merge

TUBE DIAMETER	COLLECTOR DIA./STYLE	TOYOTA #
1 3/4" - 1 7/8" - 2"	3" MERGE	<b>T1034V3AMM</b>
1 7/8" - 2"	3" MERGE	<b>T1035VAMM</b>
1 3/4" - 2"	3" MERGE	<b>T1038V2AMM</b>



UPSWEPT MERGE COLL.

Gaskets not included or available for Toyota  
Comes With 5/16" Flange

Temporary non-high temperature paint

## Esslinger Midget Headers

Designed to fit ESSLINGER RSI engines.

TUBE DIAMETER	COLLECTOR DIA./STYLE	UPSWEPT ESSLINGER #
1 3/4" - 1 7/8" - 2"	3" MERGE	<b>9174V3MMRU</b>

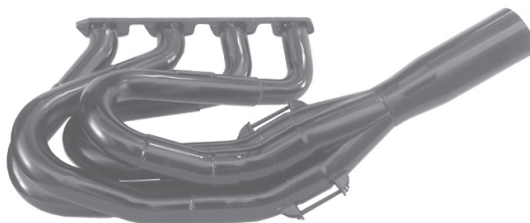

UPSWEPT MERGE

Headers come with 5/16" flange  
Gasket not included or available for Esslinger

Temporary non-high temperature paint

Designed to fit ESSLINGER ST/XT engines.

TUBE DIAMETER	COLLECTOR DIA./STYLE	ESSLINGER #
1 3/4" - 1 7/8" - 2"	3" MERGE	<b>9174V3MM</b>

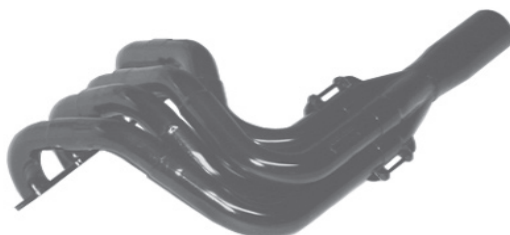

MERGE

## Chevy Midget Upswept Merge

TUBE DIAMETER	COLLECTOR DIAMETER	SPREAD PORT #
1 3/4" - 1 7/8"	3"	1074VAPMMU
1 7/8" - 2"	3"	1075VAPMMU

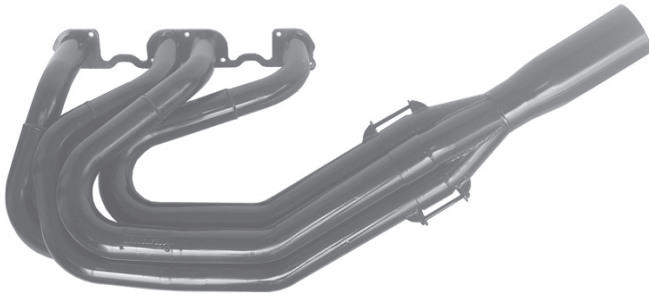

Mopar Available

Available for All Pro & Brodix GB heads  
 Comes With 5/16" Flange  
 Bolts and Gaskets included  
 Armor 400 Gaskets available for D.N & All Pro  
 Temporary non-high temperature paint

## Chevy Midget Upswept Merge

TUBE DIAMETER	COLLECTOR DIAMETER	SPREAD PORT #
1 3/4" - 1 7/8"	3"	1084VSPMM
1 7/8" - 2"	3"	1085VDNMM

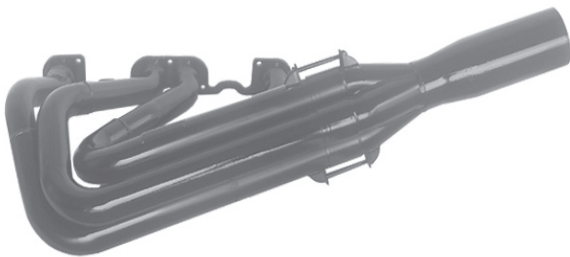

Available for All Pro & Brodix GB heads  
 Comes With 5/16" Flange  
 Bolts and Gaskets included  
 Armor 400 Gaskets available for D.N & All Pro  
 Available with Tri-Y collectors  
 Temporary non-high temperature paint

## Duratec/Ecotec Midget Merge

TUBE DIAMETER	COLLECTOR DIA./STYLE	RIGHT EXIT ECOTECH #	TUBE DIAMETER	COLLECTOR DIA./STYLE	LEFT EXIT ECOTECH #
1 3/4"	3" MERGE	1072EM	1 3/4" - 1 7/8" - 2"	3" MERGE	9074V3EM

Gasket not included  
 or available for  
 Duratec/Ecotec

TUBE DIAMETER	COLLECTOR DIA./STYLE	DURATECH #
1 5/8" - 1 3/4" - 1 7/8"	3" MERGE	9373V3MM
1 3/4" - 1 7/8" - 2"	3" MERGE	9374V3MM

Comes With 5/16" Flange

Right side exit

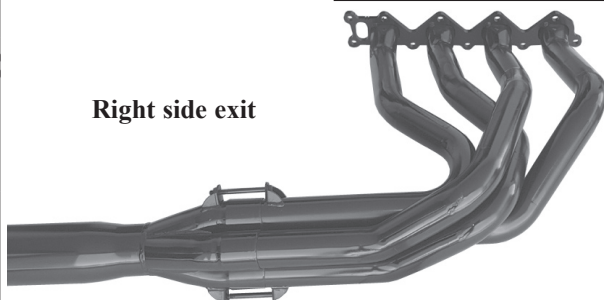

Left side exit



Tractor/Derby  
Dirt Mod.  
Crossover  
Drag 4 Cyl.  
Collectors  
180° Crossover  
Flanges/Gaskets  
Stock Clip  
Street Stock  
U & J Bends  
Chassis  
X & Y Pipes  
IMCA Mod.  
Turnouts & Extensions  
Sprint  
Misc.  
Midget  
Elbow Applications

## Mopar Midget Upswept Merge

TUBE DIAMETER	COLLECTOR DIA.	SR 11 MOPAR #
1 3/4" - 1 7/8"	3"	4074VHMMU-OHC
1 3/4" - 1 7/8" - 2"	3"	4074V3HMMU-OHC

Gasket not included or available for SR 11  
Comes With 5/16" Flange  
Temporary non-high temperature paint



## Ford Focus Midget Merge

TUBE DIAMETER	COLLECTOR DIA./STYLE	FOCUS #
1 5/8" - 1 3/4"	3" MERGE	9132VFMMU

Gasket not included or available for Ford Focus  
Comes With 5/16" Flange  
Temporary non-high temperature paint



## Fontana Midget Merge

TUBE DIAMETER	COLLECTOR DIA.	FONTANA #
1 7/8"	3" MERGE	9045MU-3
1 7/8" - 2" - 2 1/8"	3 1/2" MERGE	9045V3MU

Comes With 5/16" Flange  
Gaskets not included or available for Fontana  
Temporary non-high temperature paint

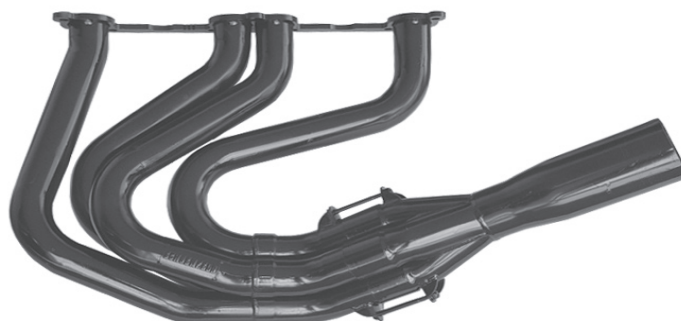

## Honda Midget Merge

TUBE DIAMETER	COLLECTOR DIA./STYLE	HONDA #
1 3/4" - 1 7/8" - 2"	3" MERGE	<b>9274V3MM</b>

Comes With 5/16" Flange  
 Gaskets not included or available for Honda

Temporary non-high temperature paint

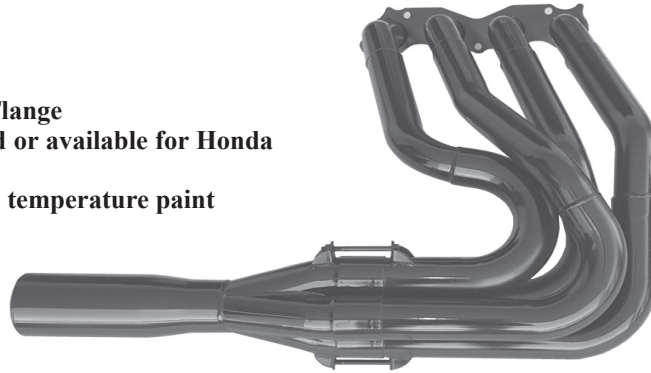

## TQ Midget Try-Y Header

TUBE DIAMETER	COLLECTOR DIAMETER	SUZUKI GSXR 4-2-1 COLL. #	TUBE DIAMETER	COLLECTOR DIAMETER	KAW. 636 4-2-1 COLL. #
1 1/2" - 1 5/8"	1 3/4"	<b>MT11713RVYR</b>	1 1/2" - 1 5/8"	1 3/4"	<b>MT11513RVYR</b>



Gaskets not included or available for TQ Midget

Temporary non-high temperature paint

## Mini Sprint Tri-Y Header

TUBE DIAMETER	COLLECTOR DIAMETER	YZ R1 2007 - 2008 1000 #
1 1/2" - 1 5/8"	2"	<b>MS11632RVY</b>

TUBE DIAMETER	COLLECTOR DIAMETER	YZ R1 05-06, 09-14 1000 #
1 1/2" - 1 5/8"	2"	<b>MS11632RVYR</b>

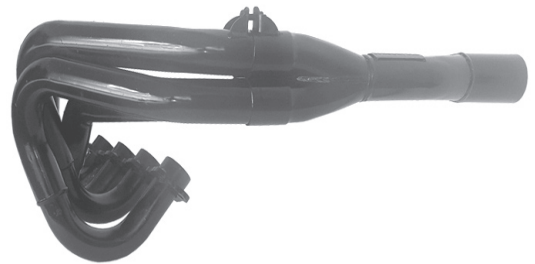

Left side exit

Temporary non-high temperature paint

## Micro Sprint Tri-Y Header

TUBE DIAMETER	COLLECTOR DIAMETER	YAMAHA R6 4-2-1 COLL. #
1 3/8"	1 3/4"	<b>MS600RY-6</b>
1 3/8" - 1 1/2"	1 3/4"	<b>MS603RVY-6</b>

TUBE DIAMETER	COLLECTOR DIAMETER	KAW. 636 4-2-1 COLL. #
1 3/8" - 1 1/2"	1 3/4"	<b>MS503RVY-6</b>

TUBE DIAMETER	COLLECTOR DIAMETER	HONDA 600RR 4-2-1 COLL. #
1 3/8" - 1 1/2"	1 3/4"	<b>MS403RVYR-6</b>

TUBE DIAMETER	COLLECTOR DIAMETER	YAMAHA R6R 4-2-1 COLL. #
1 3/8" - 1 1/2"	1 3/4"	<b>MS603RVYR-6</b>

TUBE DIAMETER	COLLECTOR DIAMETER	KAW. 600 4-2-1 COLL. #
1 3/8" - 1 1/2"	1 3/4"	<b>MS503RVYR-6</b>

TUBE DIAMETER	COLLECTOR DIAMETER	SUZUKI GSXR 4-2-1 COLL. #
1 3/8" - 1 1/2"	1 3/4"	<b>MS703RVYR-6</b>

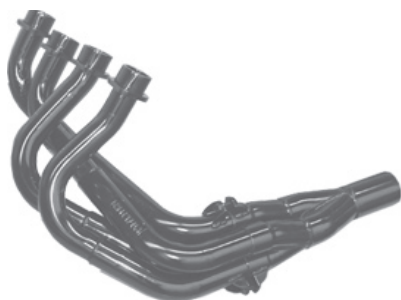

left side exit



Elbow

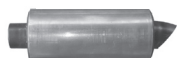

Aluminum Muffler



Steel Muffler

Available with 2" collector

Part # MS81721 - 1 3/4" INLET  
 Part # MS101721 - 1 3/4" INLET  
 Part # MS82021 - 2" INLET

Part # MS131722 - 1 3/4" INLET  
 Part # MS132022 - 2" INLET

## Over The Top Micro Tri-Y

TUBE DIAMETER	COLLECTOR DIAMETER	YAMAHA R6 4-2-1 COLL. #
1 3/8" - 1 1/2"	1 3/4"	<b>MS613RVY-4</b>

TUBE DIAMETER	COLLECTOR DIAMETER	KAW. 636 4-2-1 COLL. #
1 3/8" - 1 1/2"	1 3/4"	<b>MS513RVY-4</b>

TUBE DIAMETER	COLLECTOR DIAMETER	HONDA 600RR 4-2-1 COLL. #
1 3/8" - 1 1/2"	1 3/4"	<b>MS413RVYR-4</b>

TUBE DIAMETER	COLLECTOR DIAMETER	YAMAHA R6R 4-2-1 COLL. #
1 3/8" - 1 1/2"	1 3/4"	<b>MS613RVYR-4</b>

TUBE DIAMETER	COLLECTOR DIAMETER	KAW. 600 4-2-1 COLL. #
1 3/8" - 1 1/2"	1 3/4"	<b>MS513RVYR-4</b>

TUBE DIAMETER	COLLECTOR DIAMETER	SUZUKI GSXR 4-2-1 COLL. #
1 3/8" - 1 1/2"	1 3/4"	<b>MS713RVYR-4</b>



Left side exit



Aluminum Muffler

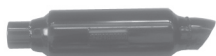

Steel Muffler

Available with 2" collector

Part # MS81721 - 1 3/4" INLET  
 Part # MS101721 - 1 3/4" INLET  
 Part # MS82021 - 2" INLET

Part # MS131722 - 1 3/4" INLET  
 Part # MS132022 - 2" INLET  
 Temporary non-high temperature paint

Tractor/Derby  
 4 Cyl. Drag  
 Collectors  
 Flanges/Gaskets  
 U & J Bends  
 X & Y Pipes  
 Turnouts & Extensions  
 Misc.  
 Elbow Applications  
 Mufflers  
 Crossover  
 180° Crossover  
 Stock Clip  
 Street Stock  
 Chassis  
 IMCA Mod.  
 Dirt Late Model  
 Micro Sprint  
 Chassis Applications



## Micro Sprint Tri-Y Header

WITH 1 1/4" INSERT

TUBE DIAMETER	COLLECTOR DIAMETER	YAMAHA R6 4-2-1 COLL. #
1 3/8"	1 3/4"	<b>MS602RY-4</b>
1 3/8"	1 3/4"	<b>MS602RY-4C</b>
1 3/8" - 1 1/2"	1 3/4"	<b>MS602RVY-4</b>
1 3/8" - 1 1/2"	1 3/4"	<b>MS602RVY-4C</b>

TUBE DIAMETER	COLLECTOR DIAMETER	YAMAHA R6 4-2-1 COLL. #
1 3/8"	1 3/4"	<b>MS602RIY-4</b>
1 3/8"	1 3/4"	<b>MS602RIY-4C</b>
1 3/8" - 1 1/2"	1 3/4"	<b>MS602RIVY-4</b>
1 3/8" - 1 1/2"	1 3/4"	<b>MS602RIVY-4C</b>

TUBE DIAMETER	COLLECTOR DIAMETER	YAMAHA R6R 4-2-1 COLL. #
1 3/8"	1 3/4"	<b>MS602RYR-4</b>
1 3/8"	1 3/4"	<b>MS602RYR-4C</b>
1 3/8" - 1 1/2"	1 3/4"	<b>MS602RVYR-4</b>
1 3/8" - 1 1/2"	1 3/4"	<b>MS602RVYR-4C</b>

TUBE DIAMETER	COLLECTOR DIAMETER	YAMAHA R6R 4-2-1 COLL. #
1 3/8"	1 3/4"	<b>MS602RIYR-4</b>
1 3/8"	1 3/4"	<b>MS602RIYR-4C</b>
1 3/8" - 1 1/2"	1 3/4"	<b>MS602RIVYR-4</b>
1 3/8" - 1 1/2"	1 3/4"	<b>MS602RIVYR-4C</b>

TUBE DIAMETER	COLLECTOR DIAMETER	KAW. 636 4-2-1 COLL. #
1 3/8"	1 3/4"	<b>MS502RY-4</b>
1 3/8"	1 3/4"	<b>MS502RY-4C</b>
1 3/8" - 1 1/2"	1 3/4"	<b>MS502RVY-4</b>
1 3/8" - 1 1/2"	1 3/4"	<b>MS502RVY-4C</b>

TUBE DIAMETER	COLLECTOR DIAMETER	KAW. 636 4-2-1 COLL. #
1 3/8"	1 3/4"	<b>MS502RIY-4</b>
1 3/8"	1 3/4"	<b>MS502RIY-4C</b>
1 3/8" - 1 1/2"	1 3/4"	<b>MS502RIVY-4</b>
1 3/8" - 1 1/2"	1 3/4"	<b>MS502RIVY-4C</b>

TUBE DIAMETER	COLLECTOR DIAMETER	HONDA 600RR 4-2-1 COLL. #
1 3/8"	1 3/4"	<b>MS402RYR-4</b>
1 3/8"	1 3/4"	<b>MS402RYR-4C</b>
1 3/8" - 1 1/2"	1 3/4"	<b>MS402RVYR-4</b>
1 3/8" - 1 1/2"	1 3/4"	<b>MS402RVYR-4C</b>

TUBE DIAMETER	COLLECTOR DIAMETER	HONDA 600RR 4-2-1 COLL. #
1 3/8"	1 3/4"	<b>MS402RIYR-4</b>
1 3/8"	1 3/4"	<b>MS402RIYR-4C</b>
1 3/8" - 1 1/2"	1 3/4"	<b>MS402RIVYR-4</b>
1 3/8" - 1 1/2"	1 3/4"	<b>MS402RIVYR-4C</b>

TUBE DIAMETER	COLLECTOR DIAMETER	SUZUKI GSXR 4-2-1 COLL. #
1 3/8"	1 3/4"	<b>MS702RYR-4C</b>
1 3/8" - 1 1/2"	1 3/4"	<b>MS702RVYR-4C</b>

TUBE DIAMETER	COLLECTOR DIAMETER	SUZUKI GSXR 4-2-1 COLL. #
1 3/8"	1 3/4"	<b>MS702RIYR-4C</b>
1 3/8" - 1 1/2"	1 3/4"	<b>MS702RIVYR-4C</b>

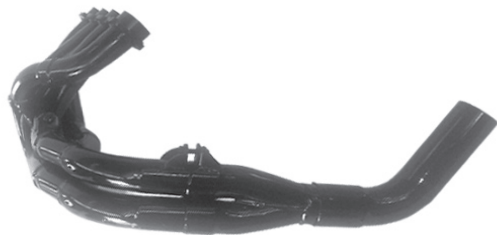

Part # MS81721 - 1 3/4" INLET  
 Part # MS101721 - 1 3/4" INLET  
 Part # MS82021 - 2" INLET

Part # MS131722 - 1 3/4" INLET  
 Part # MS132022 - 2" INLET

Temporary non-high temperature paint  
 Left side exit  
 Available with 2" collector

## Mod-Lite Tri-Y Headers



TUBE DIAMETER	COLLECTOR DIAMETER	SUZUKI GSXR 2005 - 2006 1000 #
1 1/2"	2"	<b>ML11703RY-T</b>
1 1/2" - 1 5/8"	2"	<b>ML11703RVY-T</b>

TUBE DIAMETER	COLLECTOR DIAMETER	SUZUKI GSXR 2007-2008 1000 #
1 1/2"	2"	<b>ML11703RY</b>
1 1/2" - 1 5/8"	2"	<b>ML11703RVY</b>

Tractor/Derby  
 Dirt Mod.  
 Crossover  
 Drag 4 Cyl.  
 180° Crossover  
 Collectors  
 Flanges/Gaskets  
 Stock Clip  
 Street Stock  
 U & J Bends  
 Chassis  
 X & Y Pipes  
 IMCA Mod.  
 Turnouts & Extensions  
 Micro Sprint  
 Misc.  
 Chassis Applications  
 Elbow Applications



## Chevy D.I.R.T. Modified Headers

Fits Bicknell, TEO, Troyer

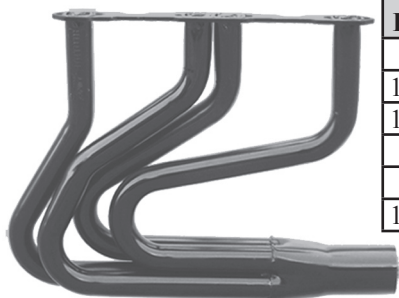

TUBE DIAMETER	COLL. DIA./LENGTH	STANDARD CHEVY #	*CRATE MOTOR #	SPEC. HEAD #
1 5/8"	3" x 8"	<b>1122B</b>	<b>1122BCM</b>	----
1 5/8" - 1 3/4"	3" x 8"	<b>1122BV-3</b>	<b>1122BVCM-3</b>	<b>1122BVSH-3</b>
1 5/8" - 1 3/4"	3 1/2" x 8"	<b>1122BV</b>	<b>1122BVCM</b>	----
1 3/4"	3" x 8"	<b>1124B-3</b>	----	----
1 3/4"	3 1/2" x 8"	<b>1124B</b>	----	----
1 3/4" - 1 7/8"	3 1/2" x 9"	<b>1124BV</b>	----	----

Cab Forward Design for Additional Muffler Clearance  
Mopar available

Fits Bicknell, TEO, Troyer

TUBE DIAMETER	COLL. DIA./LENGTH	STANDARD CHEVY #	*CRATE MOTOR #	SPEC. HEAD #
1 5/8"	3" x 8"	----	<b>1122BUCM2</b>	----
1 5/8" - 1 3/4"	3" x 8"	----	----	<b>1122BVUSH-3</b>
1 3/4" - 1 7/8"	3 1/2" x 9"	<b>1124BVU</b>	----	----

New Upswept Design

D.I.R.T Sportsman Division Spec Header 1122BCM, 1122BUCM2  
D.I.R.T 358 Sportsman Division Spec Header 1122BVSH-3, 1122BV, 1122BVUSH-3, 1124BVU

Temporary non-high temperature paint



## Chevy D.I.R.T. Modified LS1 Tri-Y Headers

Fits Bicknell, TEO, Troyer

TUBE DIAMETER	COLLECTOR DIA.	LS1 #
1 3/4" - 1 7/8"	3 1/2"	<b>1124VYLS3</b>

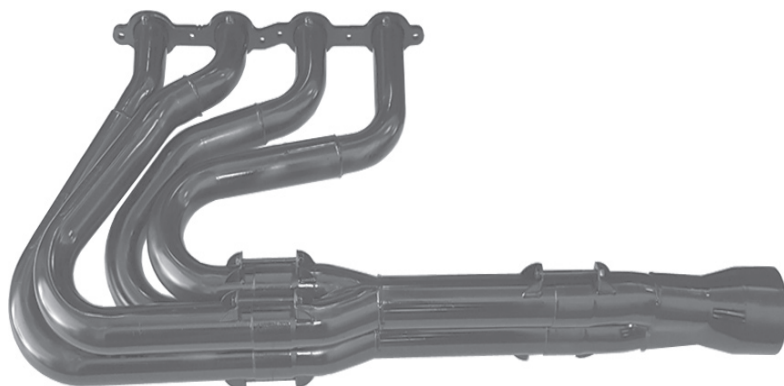

Bolts and Gaskets included  
Temporary non-high temperature paint

# S-10 Chevy Truck Forward Exit

For S-10 conversion to a small block Chevy, Exits front mid-fender

TUBE DIAMETER	COLLECTOR DIA./LENGTH	STANDARD CHEVY #	SPREAD PORT #	CHEVY 18° #
1 3/4"	3 1/2" x 8"	198A	198ASP	198A18
1 3/4" - 1 7/8"	3 1/2" x 9"	198VA	198VASP	198VA18
1 7/8" - 2"	3 1/2" x 9"	199VA	199VASP	199VA18

Temporary non-high temperature paint  
Bolts and Gaskets included



Left Side



Right Side

## LS1-LS7 Truck 1967-1999OBS Truck

5/16" flange, 16 ga. primaries, O2 sensor bungs installed in collector, excellent spark plug access.

TUBE DIAMETER	COLLECTOR DIA./LENGTH	LS1 #
1 3/4"	3" x 8"	1302LS1
1 7/8"	3" x 9"	1303LS1-3

### LS1 Ceramic Coated Headers

TUBE DIAMETER	COLLECTOR DIA./LENGTH	LS1 #
1 3/4"	3" x 8"	1302LS1-C

Temporary non-high temperature paint  
Bolts and Gaskets included  
Fits Chevy K10 Blazer 4 Wheel Drive

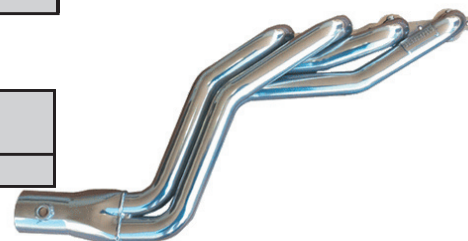

These products are intended for racing and off-road applications. Not legal for sale or use in the state of California, nor in states which have adopted California emission standards.

Chassis Applications | Midget Sprint | Dirt Late Model | IMCA Mod. | Chassis | Street Stock | Stock Clip | 180° Crossover | Crossover | Tractor/Truck | Mufflers | Elbow Applications | Misc. | Turnouts & Extensions | X & Y Pipes | U & J Bends | Flanges/Gaskets | Collectors | Drag | 4 Cyl. | Dirt Mod.

## Chevy Small Block Truck Fender Well

TUBE DIAMETER	COLLECTOR DIA./LENGTH	STANDARD CHEVY #	18° CHEVY	SPREAD PORT
1 3/4"	3 1/2" x 13"	1346	----	----
1 3/4" - 1 7/8"	3 1/2" x 13"	1346V	1346V18	1346VSP
1 7/8" - 2"	3 1/2" x 13"	1347V	1347V18	1347VSP

Temporary non-high temperature paint  
 5/16" flange, 16 ga. primaries, excellent spark plug access.  
 Exits over steering shaft and frame.  
 Fits straight or angle plug.  
 Will not fit 1967-1987 with stock heater box.  
 Bolts and Gaskets included



Clears 35" tires

## Chevy Big Block Truck Fender Well

TUBE DIAMETER	COLLECTOR DIA./LENGTH	BIG BLOCK CHEVY #	WITH E-VACS
2 1/8"	4" x 13"	2347	2347-E
2 1/4"	4" x 13"	2348	2348-E
2 3/8"	4 1/2" x 13"	2349	2349-E

396-454 fender well - 1968-1972 4WD  
 1973-1987 but requires u-jointing the steering column  
 unless a 3" body lift is used  
 Bolts and Gaskets included  
 Clears 35" tires  
 Temporary non-high temperature paint

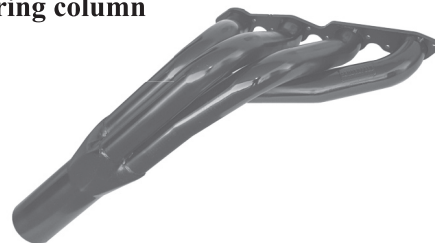
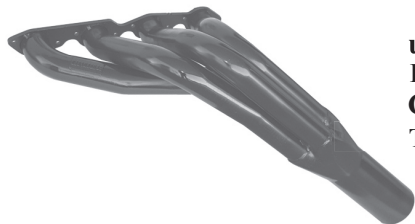

## New! 1978-1987 Chevy Truck Headers New!

16 ga. primaries, excellent spark plug access.  
 Fits straight or angle plugs.

TUBE DIAMETER	COLLECTOR DIA./LENGTH	STANDARD CHEVY #
1 5/8"	3" x 8"	1307
1 3/4"	3" x 8"	1308-3
1 7/8"	3" x 9"	1309-3
1 7/8"	3 1/2" x 9"	1309

Bolts and Gaskets included

Temporary non-high temperature paint

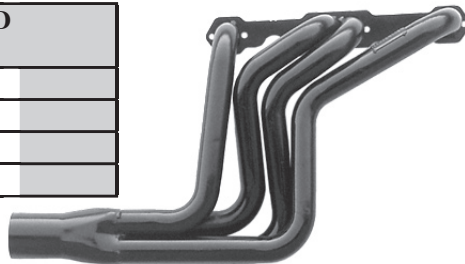



## Truck Pulling

**Small Block Chevy/LS1/Stahl – 28" Primaries - 5/16 Flange - 16 Ga. primaries**

TUBE DIAMETER	COLLECTOR DIA./LENGTH	STANDARD CHEVY #	CAB FORWARD #
1 5/8"	3" x 8"	<b>1512</b>	<b>1532</b>
1 3/4"	3 1/2" x 8"	<b>1514</b>	<b>1534</b>
1 3/4"	3 1/2" x 8"	<b>1514LS1</b>	<b>1534LS1</b>
1 7/8"	3 1/2" x 9"	<b>1515</b>	<b>1535</b>
2"	3 1/2" x 9"	<b>1516S</b>	<b>1536S</b>

CAB FORWARD

**Big Block Chevy – 31" Primaries - 5/16" Flange - 16 Ga. primaries**

TUBE DIAMETER	COLLECTOR DIA./LENGTH	STANDARD CHEVY #	CAB FORWARD #
1 5/8"	3" x 8"	<b>2512</b>	<b>2532</b>
2"	4" x 10"	<b>2516</b>	<b>2536</b>
2 1/8"	4" x 10"	<b>2517</b>	<b>2537</b>
2 1/4"	4" x 10"	<b>2518</b>	<b>2538</b>
2 3/8"	4 1/2" x 10"	<b>2519</b>	<b>2539</b>

**All Tractor Pull Available with Merge Coll**

**429-460 Big Block Ford - 30" Primaries**

May not fit with power brake booster. - 5/16" Flange

TUBE DIAMETER	COLLECTOR DIA./LENGTH	429-460 FORD #
2"	4" x 10"	<b>6516</b>
2 1/8"	4" x 10"	<b>6517</b>

Cab forward available

**Small Block Ford Windsor - 29" Primaries**

TUBE DIAMETER	COLLECTOR DIA./LENGTH	289-302-351 WINDSOR #	*DART/"N" SPORTSMAN #
1 5/8"	3" x 8"	<b>3512</b>	<b>3512N</b>
1 3/4"	3 1/2" x 8"	<b>3514</b>	<b>3514N</b>

Cab forward available

**Big Block Mopar - 28" Primaries**

Gaskets not included or available

TUBE DIAMETER	COLLECTOR DIA./LENGTH	MOPAR 440 #
1 7/8"	3 1/2" x 9"	<b>7515</b>
2"	4" x 10"	<b>7516</b>

## Demolition Derby

**Chevy / Ford / Mopar (Exits thru hood)**

5/16" Flange - 16 Ga. primaries

TUBE DIAMETER	STANDARD CHEVY #	WINDSOR 289-302-351 #	MOPAR 318-340-360 #	MOPAR 361-383-440 #
1 5/8"	<b>1522</b>	<b>3522</b>	<b>4522</b>	----
1 3/4"	----	----	----	<b>7524</b>

Temporary non-high temperature paint

Tractor/Derby  
Dirt Mod.  
Crossover  
Drag 4 Cyl.  
Collectors  
180° Crossover  
Flanges/Gaskets  
Stock Clip  
Street Stock  
U & J Bends  
Chassis  
X & Y Pipes  
Turnouts & Extensions  
Misc.  
Midget  
Elbow Applications  
Chassis Applications  
Mufflers

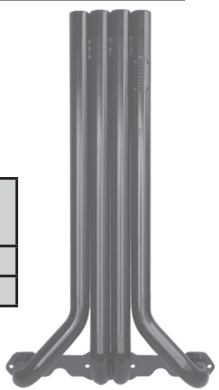
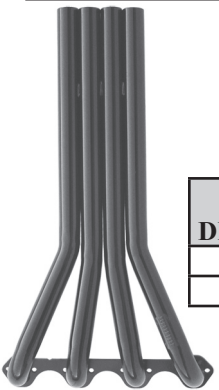
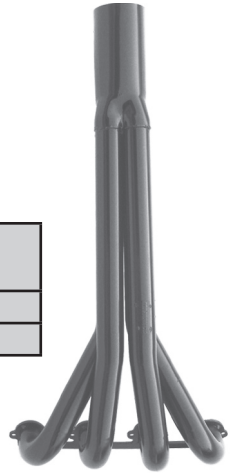
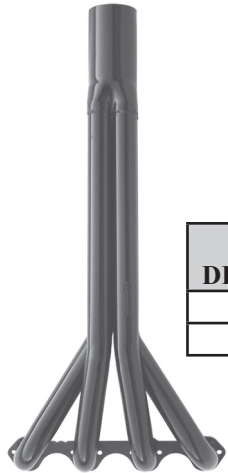
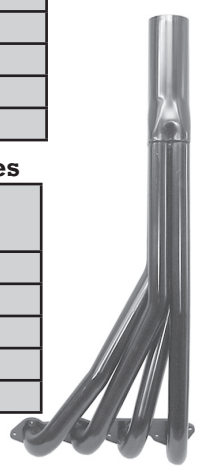
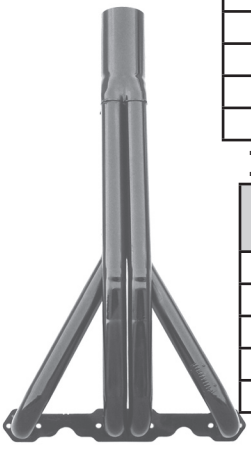

## IMCA Modified

CHASSIS	162-68	162-98H	11629H	152-152E	162	172-176	1101	1125	1131	1137	1146	1155L	1155LBR	1176	1186	1166	1106
BANDIT													1155LBRF		X		X
BEAKBUILT												X			X		X
BILLSBUILT												1155LB					X
BMS							1101B				X				X		X
BOB PIERCE				X	X	X									X		X
CAM											X				X	X	X
DIAMOND								X							1186DC		
DIRT BOSS	X	X	X		X										X	X	X
DIRTWORKS		X		X	X	X						0		X	X		X
DW-8		X		X	X	X						0		X	X		X
EDGE	X	X		X	X	X								X	X		X
ELITE								X	1131EW								X
FLEXIFLYER	X		X	X	X									X			
FR 1				X		X									X		
GRT	X			X	X							1155LB			2		X
HARRIS	X	X	X	X	X	X	1101H		1131H			1155LBR	2016+	X	0		X
HOFFMAN				X	X	X	X				0			X	X	0	X
HORNADAY								X									
HOT CHASSIS				X	X	X								X	X		
HUGHES	X	X	X		X	X	1101H		1131H		X			X	X	X	X
IMPRESSIVE															X		X
IROC													1155LBRW				
J CAR																X	
JET RACING	X	X		X	X	X								X	X		X
KRAFT		X														X	
LARRY SHAW	X			X	X	X					X	X		X	X	0	X
LEATHAL																	X
LG2												1155LBF					X
LIGHTNING					X	X								X			
LONGHORN									1131EW								
LOU FEGERS					X									X	1		
MAD MAN												1155LB			X		X
MB CUSTOMS							X					1155LBF					
MILLINIUM									2017+			1155LB					
M & M														X	0		
PRO-CHASSIS	X			X	X	0								X	X		
QUICK					X										X		
RAGE									X		X				X	X	
RAZOR			X				X		1131W		X				X		
RUHLMAN												1155LB					
SARDESON	X	X		X	X	X								X	X		
SIDEBITER	X	X	X		X		X					1155LG		X			
SKYROCKET		X	X		X	X				X							X
SMILEYS	X	X		X	X	X									X		
SPEEDWAY		X		X	X	X											
SWARTZ				X		X											
SYCLONE	X			X	X	X									X		X
TAYLOR M/S												X					X
THROWINDIRT															X	X	
TRE											X				X	X	
VICTORY	X	X	X		X	X						X			X		X
VICTORY CIRCLE													X				
WARRIOR				X	X												

Tractor/Derby  
Dirt Mod. 4 Cyl. Drag Collectors 180° Crossover Flanges/Gaskets Stock Clip U & J Bends Chassis IMCA Mod. Dirt Late Model Sprint Midget Chassis Applications  
Mufflers



**Flanges & Gaskets Small Block Chevy**

\* = 5/16" thick

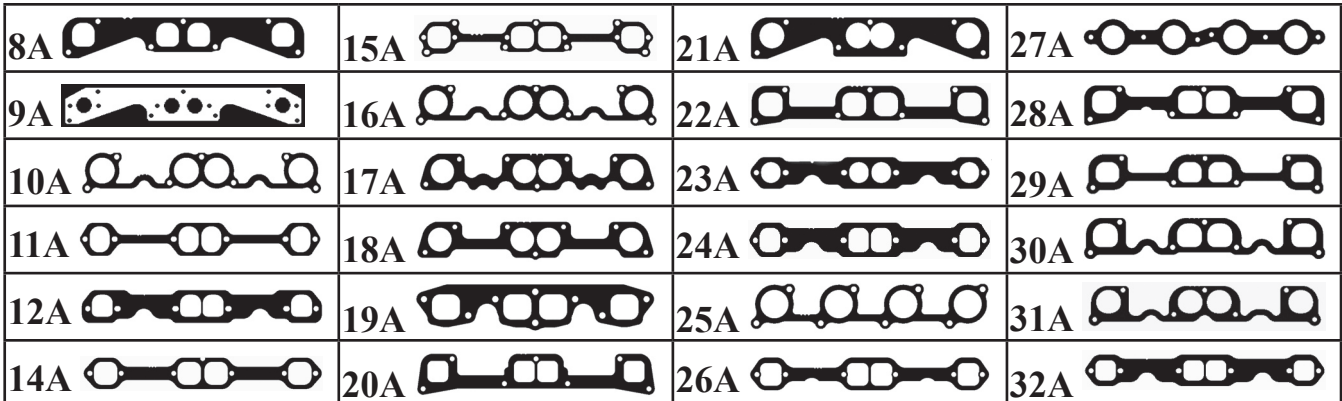

REF#	CYLINDER HEAD DESCRIPTION	TUBE DIA.	PORT SHAPE	STAMP/ CNC	FLANGE PART #	GASKET PART #
9A	23° SB ADAPTER KIT 3/8 THICK (2 PLATES, 2 INNER GASKETS & BOLTS)	1 1/4"	ROUND	CNC	<b>0101K</b>	<b>01500</b>
9A	23° SB ADAPTER (INNER ALUM.)	1 1/4"	ROUND	CNC	<b>0101</b>	<b>01500</b>
12A	CRATE MOTOR/FASTBURN-LT1/LT4	1 5/8"	D	CNC	<b>0103</b>	<b>01560</b>
*12A	CRATE MOTOR/FASTBURN-LT1/LT4	1 5/8"	D	CNC	<b>*0103-5</b>	<b>01560</b>
12A	CRATE MOTOR/FASTBURN-LT1/LT4	1 3/4"	D	CNC	<b>0104</b>	<b>01560</b>
*12A	CRATE MOTOR/FASTBURN-LT1/LT4	1 3/4"	D	CNC	<b>*0104-5</b>	<b>01560</b>
11A	STANDARD SB (LITE) 265-400	1 3/4"	OVAL	CNC	<b>0106</b>	<b>01510</b>
11A	STANDARD SB (LITE) 265-400	1 7/8"	REC	CNC	<b>0107</b>	<b>01510</b>
23A	STANDARD SB 265-400	1 1/2"	ROUND	CNC	<b>01091</b>	<b>01500</b>
32A	STANDARD SB 265-400	1 5/8"	SQUARE	CNC	<b>01101</b>	<b>01501</b>
*32A	STANDARD SB 265-400	1 5/8"	SQUARE	CNC	<b>*01101-5</b>	<b>01501</b>
----	BRODIX TRACK 1/SPEC. HEAD	1 5/8"	SAP	CNC	<b>01105</b>	<b>01570</b>
24A	STANDARD SB 265-400	1 3/4"	D	CNC	<b>01111</b>	<b>01511</b>
*24A	STANDARD SB 265-400	1 3/4"	D	CNC	<b>*01111-5</b>	<b>01511</b>
----	STANDARD SB 265-400	1 3/4"	OVAL	----	----	<b>01510</b>
24A	STANDARD SB 265-400	1 7/8"	REC	CNC	<b>0112</b>	<b>01510</b>
14A	SB 18° DEGREE/ PRO ACTION 14°- 6 BOLT	1 3/4"	SAP	CNC	<b>0115</b>	<b>01540</b>
*14A	SB 18° DEGREE/ PRO ACTION 14°- 6 BOLT	1 3/4"	SAP	CNC	<b>*0115-5</b>	<b>01540</b>
14A	SB 18° DEGREE/ PRO ACTION 14°- 6 BOLT	1 7/8"	SAP	CNC	<b>0116</b>	<b>01540</b>
*14A	SB 18° DEGREE/ PRO ACTION 14°- 6 BOLT	1 7/8"	SAP	CNC	<b>*0116-5</b>	<b>01540</b>
14A	SB 18° DEGREE/ PRO ACTION 14°- 6 BOLT	2"	SAP	CNC	<b>0117</b>	<b>01540</b>
*14A	SB 18° DEGREE/ PRO ACTION 14°- 6 BOLT	2"	SAP	CNC	<b>*0117-5</b>	<b>01540</b>
8A	SB BRODIX SPREAD PORT(X)	1 3/4"	D	CNC	<b>0119</b>	<b>01533</b>
8A	SB BRODIX SPREAD PORT(X)	1 7/8"	D	CNC	<b>0120</b>	<b>01533</b>
10A	SB SPREAD PORT (LITE)(X)	1 3/4"	D	CNC	<b>0121</b>	<b>01533</b>
10A	SB SPREAD PORT (LITE)(X)	1 7/8"	D	CNC	<b>0122</b>	<b>01532</b>
10A	SB SPREAD PORT (LITE)(X)	2"	ROUND	CNC	<b>0123</b>	<b>01531</b>
29A	BRODIX ASCS/SUPRA	1 3/4"	SAP	CNC	<b>01191</b>	<b>01530</b>
30A	SB DOWN NOZZLE (SPREAD PORT)	1 7/8"	D	CNC	<b>01251</b>	<b>01531</b>
16A	SB DOWN NOZZLE (SPREAD PORT)	2"	ROUND	CNC	<b>0126</b>	<b>01531</b>
16A	SB DOWN NOZZLE (SPREAD PORT)	2 1/8"	ROUND	CNC	<b>0127</b>	<b>01531</b>
31A	SB DOWN NOZZLE ALL PRO - GB23/24	1 7/8"	SAP	CNC	<b>01850</b>	<b>01532</b>
31A	SB DOWN NOZZLE ALL PRO - GB23/24	2"	SAP	CNC	<b>01860</b>	<b>01532</b>
17A	SB ALAN JOHNSON 18 DEGREE	1 7/8"	ROUND	CNC	<b>0130</b>	----
17A	SB ALAN JOHNSON 18 DEGREE	2"	ROUND	CNC	<b>0131</b>	----
18A	SB 18° (OUTER, HOOKER ADAPTER)	1 7/8"	ROUND	CNC	<b>0133</b>	----
18A	SB 18° (OUTER, HOOKER ADAPTER)	2"	ROUND	CNC	<b>0134</b>	----
19A	SB SB2	1 7/8"	SAP	CNC	<b>0135</b>	<b>01590</b>
19A	SB SB2	2"	SAP	CNC	<b>0136</b>	<b>01590</b>
20A	SB PONTIAC HEAD (7 BOLT) # 867	1 3/4"	SAP	CNC	<b>0142</b>	----
20A	SB PONTIAC HEAD (7 BOLT) # 867	1 7/8"	SAP	CNC	<b>0143</b>	----

Chassis Applications | Midget | Sprint | Dirt Late Model | IMCA Mod. | Chassis | Street Stock | Stock Clip | 180° Crossover | Crossover | Tractor/Derby | Turnouts & Extensions | X & Y Pipes | U & J Bends | Flanges/Gaskets | Collectors | Drag | 4 Cyl. | Dirt Mod.

SAP = Same as port  
\* = 5/16" thick

## (Small Block Chevy Cont.)

REF#	CYLINDER HEAD DESCRIPTION	TUBE DIA.	PORT SHAPE	STAMP/ CNC	FLANGE PART #	GASKET PART #
21A	SB STAHL (OUTER FLANGE)	1 3/4"	ROUND	CNC	0148	0152
21A	SB STAHL (OUTER FLANGE)	1 7/8"	ROUND	CNC	0144	0152
21A	SB STAHL (OUTER FLANGE)	2"	ROUND	CNC	0145	0152
21A	SB STAHL (OUTER FLANGE)	2 1/8"	ROUND	CNC	0146	0152
22A	SB 18° BRODIX SPREAD PORT(C)	1 7/8"	SAP	CNC	0161	01530
15A	SB 18° DART (Dual Bolt Pattern)	1 7/8"	SAP	CNC	0164	01540
15A	SB 18° DART (Dual Bolt Pattern)	2"	SAP	CNC	0165	01540
25A	SBC BRODIX (BD)	1 7/8"	ROUND	CNC	0167	----
25A	SBC BRODIX (BD)	2"	ROUND	CNC	0168	----
25A	SBC BRODIX (BD)	2 1/8"	ROUND	CNC	0169	----
26A	SBC PRO-ACTION 23°	1 7/8"	SAP	CNC	0175	01511
*27A	SBC LS1-LS7	1 5/8"	ROUND	CNC	*0177	01780
*27A	SBC LS1-LS7	1 3/4"	ROUND	CNC	*0178	01780
*27A	SBC LS1-LS7	1 7/8"	ROUND	CNC	*0179	01780
28A	SBC PRO-ACTION 14° - 7 BOLT	1 7/8"	SAP	CNC	0181	----

## Big Block & 6 Cylinder Chevy

\* = 5/16" thick

REF#	CYLINDER HEAD DESCRIPTION	TUBE DIA.	PORT SHAPE	STAMP/ CNC	FLANGE PART #	GASKET PART #
*30B	BB 396-454	1 5/8"	ROUND	CNC	*0208	0250
*30B	BB 396-454	1 7/8"	ROUND	CNC	*0210	02510
*30B	BB 396-454	2"	SAP	CNC	*0211	02510
*30B	BB 396-454	2 1/8"	ROUND	CNC	*0212	02520
*30B	BB 396-454	2 1/4"	ROUND	CNC	*0213	02520
31B	V-6 18 DEGREE	1 3/4"	SAP	CNC	0830	----
31B	V-6 18 DEGREE	1 7/8"	SAP	CNC	0832	----
32B	V-6 STANDARD	1 5/8"	SAP	CNC	08311	08341
32B	V-6 STANDARD	1 3/4"	OVAL	CNC	08330	08341

\* = 5/16" thick

## Big Block Ford



REF#	CYLINDER HEAD DESCRIPTION	TUBE DIA.	PORT SHAPE	STAMP/ CNC	FLANGE PART #	GASKET PART #
*37C	429-460 FORD	1 7/8"	SAP	CNC	*0611	06511
*37C	429-460 FORD	2"	SAP	CNC	*0612	06511
*37C	429-460 FORD	2 1/8"	SAP	CNC	*0613	06511
*37C	429-460 FORD COBRA	2 1/8"	SAP	CNC	*0613C	06511

## V-6 & 4 Cylinder Ford & Toyota

REF#	CYLINDER HEAD DESCRIPTION	TUBE DIA.	PORT SHAPE	STAMP/ CNC	FLANGE PART #	GASKET PART #
38D	SVO RACING HEAD (ALUM.) V-6	1 3/4"	SAP	CNC	0630	----
39D	2000cc (4 CYLINDER)	1 1/2"	OVAL	CNC	FF20	FG20
39D	2000cc (4 CYLINDER)	1 5/8"	OVAL	CNC	FF21	FG20
40D	2300cc (4 CYLINDER)	1 1/2"	OVAL	CNC	FF23	FG23
40D	2300cc (4 CYLINDER)	1 5/8"	OVAL	CNC	FF24	FG23
*41D	TOYOTA V-8	1 7/8"	SAP	CNC	*TF41	----

Tractor/Derby  
Dirt Mod.  
4 Cyl. Drag  
Collectors  
180° Crossover  
Flanges/Gaskets  
Stock Clip  
Street Stock  
U & J Bends  
Chassis  
X & Y Pipes  
IMCA Mod.  
Turnouts & Extensions  
Dirt Late Model  
Sprint  
Misc.  
Midget  
Chassis Applications  
Elbow Applications  
Mufflers



**Small Block Ford**

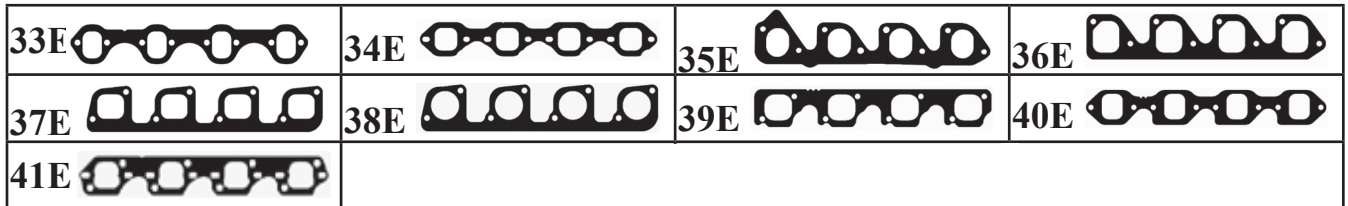

REF#	CYLINDER HEAD DESCRIPTION	TUBE DIA.	PORT SHAPE	STAMP/ CNC	FLANGE PART #	GASKET PART #
33E	289W - 351W / GT40	1 5/8"	SAP	CNC	0306	03500
33E	289W - 351W / GT40	1 3/4"	SAP	CNC	0309	03500
34E	SVO "N" / DART WIDE BOLTS	1 5/8"	SAP	CNC	0311	03520
34E	SVO "N" / DART WIDE BOLTS	1 3/4"	SAP	CNC	0312	03520
41E	BRODIX CNC / STS T1	1 5/8"	SAP	CNC	03155	03520
41E	BRODIX CNC / STS T1	1 3/4"	SAP	CNC	03156	03520
41E	BRODIX CNC / STS T1	1 7/8"	SAP	CNC	03157	03520
34E	EDELBROCK/MCGUNEGILL	1 3/4"	SAP	CNC	03151	03520
34E	EDELBROCK	1 7/8"	SAP	CNC	0316	03520
39E	EDELBROCK / KUNTZ	1 7/8"	SAP	CNC	0318	----
40E	CRATE MOTOR/Z304	1 5/8"	SAP	CNC	0320	03520
40E	CRATE MOTOR/Z304	1 3/4"	SAP	CNC	0321	03520
35E	351 CLEVELAND (2 BARREL) 351	1 3/4"	OVAL	STAMP	0510	----
36E	CLEVELAND (4 BARREL) SVO	2"	SAP	CNC	0512	----
37E	SVO C3/C33 YATES (ALUM.)	1 7/8"	SAP	CNC	0602	----
38E	SVO D3 YATES (ALUM.)	1 7/8"	ROUND	CNC	0603	----

**Mopar**

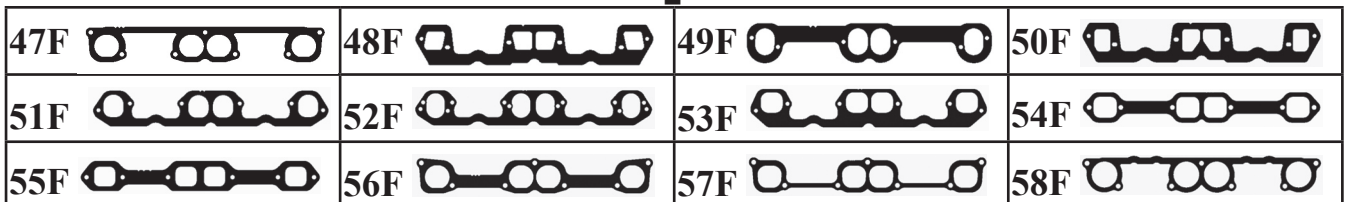

REF#	CYLINDER HEAD DESCRIPTION	TUBE DIA.	PORT SHAPE	STAMP/ CNC	FLANGE PART #	GASKET PART #
58F	W-9 RAISED INTAKE (LITE)	1 7/8"	SAP	CNC	0404	----
58F	W-9 RAISED INTAKE (LITE)	2"	ROUND	CNC	0405	----
50F	273-318-340-360	1 5/8"	SAP	CNC	0410	04500
50F	273-378-340-360	1 3/4"	SAP	CNC	0411	04500
51F	W-2 (4 3/4" CNTR. BOLTS)	1 3/4"	D	CNC	0414	----
52F	W-2 (4" OR 4 3/4" CNTR. BOLTS)	1 5/8"	OVAL	CNC	0417	----
52F	W-2 (4" OR 4 3/4" CNTR. BOLTS)	1 3/4"	OVAL	CNC	0418	----
53F	W-5	1 3/4"	SAP	CNC	0420	----
54F	W-7	1 7/8"	SAP	CNC	0423	----
56F	W-9	1 7/8"	ROUND	CNC	0407	----
56F	W-9	2"	SAP	CNC	0408	----
47F	W-9 (LITE)	1 7/8"	SAP	CNC	0455	----
57F	W-9 (LITE)	2"	SAP	CNC	0426	----
55F	440 WEDGE (INDY)	1 7/8"	SAP	CNC	0427	----
55F	440 WEDGE (INDY)	2"	SAP	CNC	0428	----
55F	440 WEDGE (INDY)	2 1/8"	SAP	CNC	0430	----
55F	440 WEDGE (INDY)	2 1/4"	SAP	CNC	0431	----
48F	MAGNUM CRATE MOTOR	1 5/8"	SAP	CNC	0432	----
55F	440 IRON/383	1 3/4"	SAP	CNC	0434	----
55F	440 IRON/383	1 7/8"	SAP	CNC	0435	----
55F	440 IRON/383	2"	SAP	CNC	0436	----
49F	MOPAR W2 (B1/BA-ASCS)	1 3/4"	OVAL	CNC	0441	----

Tractor/Derby  
Crossover  
Crossover  
180° Crossover  
Street Stock  
Stock Clip  
IMCA Mod.  
Chassis  
Sprint  
Dirt Late Model  
Turnouts & Extensions  
Misc.  
Elbow Applications  
Mufflers  
U & J Pipes  
Flanges/Gaskets  
Collectors  
Drag  
4 Cyl.  
Dirt Mod.



## Reducers

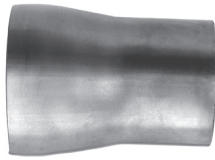

INLET	OUTLET	PART #
2 1/2" I.D.	3" O.D.	<b>2530ID</b>
3" I.D.	2 1/2" O.D.	<b>2530</b>
3 1/2" I.D.	2 1/2" O.D.	<b>2535</b>
2 3/4" I.D.	3" O.D.	<b>2730</b>
3 1/2" I.D.	3" O.D.	<b>3035</b>
3" I.D.	3 1/2" O.D.	<b>3530</b>
3" I.D.	3" O.D.	<b>3030</b>
3" I.D.	3" I.D.	<b>3030ID</b>
3 1/2" I.D.	3 1/2" O.D.	<b>3535</b>
3 1/2" I.D.	3 1/2" I.D.	<b>3535ID</b>
3" I.D.	4" O.D.	<b>4030</b>
4" I.D.	3 1/2" O.D.	<b>4035</b>

## Header Bolts

NEW 5/16" Head

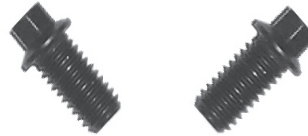

DESCRIPTION	PART #
3/8" x 3/4" x 5/16" HEX HEAD, 12 PACK	<b>3006-12</b>
3/8" x 3/4" x 5/16" HEX HEAD, 14 PACK	<b>3006-14</b>
3/8" x 3/4" x 5/16" HEX HEAD, 16 PACK	<b>3006-16</b>
3/8" x 3/4" FLAT HEAD, 12 PACK	<b>3001-12</b>
3/8" x 1" x 5/16" HEX HEAD, 12 PACK	<b>3002-12</b>
5/16" x 3/4" x 3/8" HEX HEAD (MOPAR) - 12 PACK	<b>3003-12</b>
8mm x 20mm (LS1-LS7) 12 PACK	<b>3004-12</b>
8mm x 20mm (2000 PINTO) 8 PACK	<b>3004-8</b>
10mm x 22mm (2300 PINTO) 8 PACK	<b>3005-8</b>



## U & J Mandrel Bends

18 GAUGE TUBING			16 GAUGE TUBING		
U BENDS #	J BENDS #	TUBE DIA.	BEND RADIUS	U BENDS #	J BENDS #
<b>013718U</b>	<b>013718J</b>	1 3/8"	2 1/2"	----	----
<b>015018U</b>	<b>015018J</b>	1 1/2"	2 1/2"	<b>015016U</b>	<b>015016J</b>
<b>016218U</b>	<b>016218J</b>	1 5/8"	2 1/2"	<b>016216U</b>	<b>016216J</b>
<b>017518U</b>	<b>017518J</b>	1 3/4"	2 1/2"	<b>017516U</b>	<b>017516J</b>
<b>018718U</b>	<b>018718J</b>	1 7/8"	3"	<b>018716U</b>	<b>018716J</b>
<b>018718U-40</b>	<b>018718J-40</b>	1 7/8"	4"	<b>018716U-40</b>	<b>018716J-40</b>
<b>020018U</b>	<b>020018J</b>	2"	3"	----	----
<b>020018U-40</b>	<b>020018J-40</b>	2"	4"	----	----
<b>021218U</b>	<b>021218J</b>	2 1/8"	3"	----	----
<b>021218U-35</b>	<b>021218J-35</b>	2 1/8"	3 1/2"	----	----
<b>022518U</b>	<b>022518J</b>	2 1/4"	3 1/2"	<b>022516U</b>	<b>022516J</b>
<b>023718U</b>	<b>023718J</b>	2 3/8"	3 1/2"	----	----
<b>025018U</b>	<b>025018J</b>	2 1/2"	4"	----	----

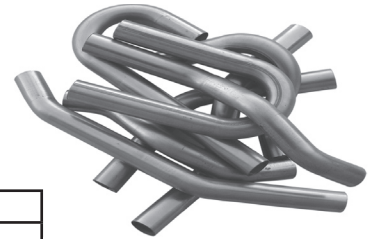

## Misc. Bends

Approx. 36 Ft.  
18ga. Mild Steel  
MB150 16ga.

TUBE DIA.	PART #
1 3/8"	<b>MB137</b>
1 1/2"	<b>MB150</b>
1 5/8"	<b>MB162</b>
1 3/4"	<b>MB175</b>
1 7/8"	<b>MB187</b>
2"	<b>MB200</b>
2 1/8"	<b>MB212</b>
2 1/4"	<b>MB225</b>
2 3/8"	<b>MB237</b>

U Bends have 9" legs & J Bends have 3" and 15" legs (Straight Part) -- 2 1/4" U Bends have 7 1/2" legs

## O2 Bung

BUNG PART #	SIZE
<b>100-14</b>	18 mm

INSTALLED

BUNG PART #	SIZE
<b>100-15</b>	18 mm



## Flanges & Gaskets

FLANGE PART #	FLANGE ID.	BOLT HOLES	GASKET PART #
<b>250CR</b>	2 1/2"	3	<b>250CG</b>
<b>300CR</b>	3"	3	<b>300CG</b>
<b>350CR</b>	3 1/2"	3	<b>350CG</b>



## Collectors



SLIPS OVER	COLL DIA.	# OF TUBES	STYLE 3 PART #	STYLE 6 PART #	STYLE 8 PART #	STYLE 9 PART #	STYLE 9H #
1 1/2"	3"	4	SO53043	SO53046	SO53048	SO53049	SO53049H
1 5/8"	3"	4	SO63043	SO63046	SO63048	SO63049	SO63049H
1 5/8"	3 1/2"	4	SO63543	SO63546	SO63548	SO63549	SO63549H
1 3/4"	3 1/2"	4	SO73543	SO73546	SO73548	SO73549	SO73549H
1 7/8"	3 1/2"	4	SO83543	SO83546	SO83548	SO83549	SO83549H



*-2 PART #	-1 PART #	SLIPS OVER	COLL. DIA.	# OF TUBES	PART #	COLL. LEN.
----	ASK	1 1/2"	3"	3	WO53030	8"
----	ASK	1 5/8"	3"	3	WO63030	8"
----	ASK	1 3/4"	3"	3	WO73030	8"
----	ASK	1 7/8"	3"	3	WO83030	8"
----	ASK	2"	3"	3	WO03030	8"
----	SO53041	1 1/2"	3"	4	WO53040	8"
SO63042	SO63041	1 5/8"	3"	4	WO63040	8"
SO73042	SO73041	1 3/4"	3"	4	WO73040	8"
SO63542	SO63541	1 5/8"	3 1/2"	4	WO63540	8"
SO73542	SO73541	1 3/4"	3 1/2"	4	WO73540	8"
SO83542	SO83541	1 7/8"	3 1/2"	4	WO83540	9"
SO03542	SO03541	2"	3 1/2"	4	WO03540	9"
----	----	2 1/8"	3 1/2"	4	WO13540	9"
----	SO04041	2"	4"	4	WO04040	10"
----	SO14041	2 1/8"	4"	4	WO14040	10"
----	----	2 1/4"	4"	4	WO24040	10"

## Merge Collectors



Temporary non-high temperature paint

SLIPS OVER	MERGE DIAMETER	OUTLET DIAMETER	PART #
1 3/4"	2 1/2"	3"	SOM72530
1 7/8"	2 1/2"	3"	SOM82530
2"	2 1/2"	3"	SOM02530
1 3/4"	2 3/4"	3 1/2"	SOM72735
1 7/8"	2 3/4"	3 1/2"	SOM82735
2"	2 3/4"	3 1/2"	SOM02735
2 1/8"	2 3/4"	3 1/2"	SOM12735
2 1/4"	2 3/4"	3 1/2"	SOM22735
2 3/8"	3 1/2"	4"	SOM33540

Chassis Applications | Midget Sprint | Dirt Late Model | IMCA Mod. | Chassis Turnouts & Extensions | X & Y Pipes | U & J Bends | Street Stock | Stock Clip | 180° Crossover | Crossover | Drag | 4 Cyl. | Tractor/Derby | Dirt Mod.

## Collector Numbering System

COLL. TYPE		*SLIP OVER		COLL DIA.		# OF TUBES		COLL. STYLE	
SLIP-ON	<b>SO</b>	1 1/2"	<b>5</b>	3"	30	6 CYL.	<b>3</b>	WELD-ON	<b>0</b>
WELD-ON	<b>WO</b>	1 5/8"	<b>6</b>	3 1/2"	35	8 CYL.	<b>4</b>	STYLE 1	<b>1</b>
		1 3/4"	<b>7</b>	4"	40			STYLE 2	<b>2</b>
		1 7/8"	<b>8</b>					30°	<b>3</b>
		2"	<b>0</b>					60°	<b>6</b>
		2 1/8"	<b>1</b>					60° ROTATED	<b>6R</b>
		2 1/4"	<b>2</b>					90° INSIDE	<b>8</b>
								90° ROTATED	<b>8R</b>
								90° OUTSIDE	<b>9</b>
								90° HARRIS	<b>9H</b>

Example: **SO63049H**

\*Indicates tube diameter the collector slips over.

## 2 Into 1 Y Pipes (Collectors)



2 Into 1 Y Pipe 60°



2 Into 1 Y Pipe

SLIPS OVER	COLL. DIA.	ANGLE	PART #
1 5/8"	1 7/8"	----	<b>Y16S1818</b>
1 3/4"	2"	----	<b>Y17S2020</b>
1 7/8"	2 1/8"	----	<b>Y18S2121</b>
1 7/8"	2 1/2" - 3"	----	<b>Y18S2530</b>
2"	2 1/4"	----	<b>Y20S2222</b>
2"	2 1/2" - 3"	----	<b>Y20S2530</b>
2"	2 1/2" - 3"	<b>60°</b>	<b>Y20S2530-60</b>
2 1/8"	2 1/2"	----	<b>Y21S2525</b>
2 1/8"	2 1/2" - 3"	----	<b>Y21S2530</b>
2 1/8"	2 1/2" - 3"	<b>60°</b>	<b>Y21S2530-60</b>
2 1/8"	2 3/4" - 3 1/2"	----	<b>Y21S2735</b>
2 1/8"	2 3/4" - 3 1/2"	<b>60°</b>	<b>Y21S2735-60</b>
2 1/4"	2 1/2" - 3"	----	<b>Y22S2530</b>
2 1/4"	2 1/2" - 3"	<b>60°</b>	<b>Y22S2530-60</b>
2 1/4"	2 3/4" - 3 1/2"	----	<b>Y22S2735</b>
2 1/4"	2 3/4" - 3 1/2"	<b>60°</b>	<b>Y22S2735-60</b>
2 1/2"	2 3/4" - 3 1/2"	----	<b>Y25S2735</b>
2 1/2"	2 3/4" - 3 1/2"	<b>60°</b>	<b>Y25S2735-60</b>



Tab kits include Tabs, Bolts, Lock Nuts and Washers. (except 4001-12)

## Tab Kits

PART #	DESCRIPTION
4003-1	2 TABS/1 BOLT/1 LOCK NUT/2 WASHERS
4003-2	4 TABS/2 BOLTS/2 LOCK NUTS/4 WASHERS
4003-4	8 TABS/4 BOLTS/4 LOCK NUTS/8 WASHERS
4003-6	12 TABS/6 BOLTS/6 LOCK NUTS/12 WASHERS
4000-6	6 BOLTS/6 LOCK NUTS/12 WASHERS
4001-12	12 TABS (TABS ONLY)

## Exhaust Elbows

DIAMETER	ANGLE°	CLR	A LENGTH	B LENGTH	PART #
2 1/2"	45°	4"	5 1/4"	4 3/4"	2545
2 1/2"	90°	4"	5 1/4"	4 7/8"	2590
3"	30°	5"	6 1/2"	6 3/4"	3031
3"	30°	5"	1 1/4"	6 3/4"	30310
3"	30°	5"	15 1/2"	6"	3032
3"	42°	5"	10"	10"	3042
3"	45°	5"	5"	6"	3045
3"	60°	5"	5"	6"	3060
3"	60°	5"	1 1/4"	6"	30610
3"	80°	5"	4 1/2"	4 1/2"	3080
3"	80°	5"	1 5/8"	5"	3081
3"	90°	5"	4 1/2"	4 1/2"	3090
3"	90°	5"	2"	2 1/2"	3091
3 1/2"	30°	5"	6 1/4"	6"	3531
3 1/2"	30°	5"	1 1/4"	6 3/4"	35310
3 1/2"	30°	5"	15 1/2"	6"	3532
3 1/2"	42°	5"	10"	10"	3542
3 1/2"	45°	5"	6 1/2"	3 1/2"	3545
3 1/2"	60°	5"	6"	1 1/2"	3560
3 1/2"	60°	5"	1 1/4"	6"	35610
3 1/2"	80°	5"	5 1/4"	2 3/4"	3580
3 1/2"	90°	5"	6"	2 3/4"	3590
3 1/2"	90°	5"	2"	2 1/2"	3591
4"	45°	6"	6 1/2"	8 1/2"	*4045
4"	90°	6"	3"	3"	*4090
5"	45°	6"	6"	6"	5045
5"	90°	5"	1 1/2"	1 1/2"	5090

\*Aluminized

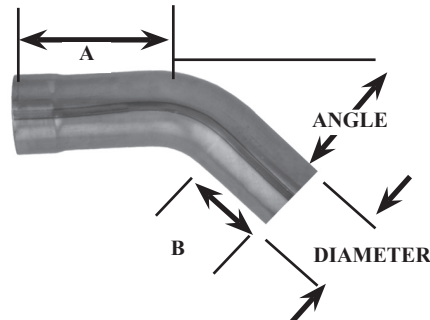

CLR = Center Line Radius\*  
All elbows and turn outs are expanded on A end

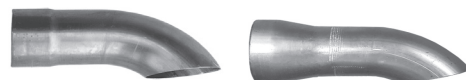

## Turnouts

Part # 2525-3 slips over 3"

SIZE	LENGTH	PART #
2 1/2"	10"	2525-3
2 1/2"	10"	2525
3"	4 1/4"	3023
3"	8"	3024
3"	10"	3025
3"	15 1/2"	3026
3 1/2"	4 1/2"	3523
3 1/2"	8"	3524
3 1/2"	10"	3525
4"	10 1/2"	*4025
5"	12"	5025

## Extensions



LENGTH	2 1/2" DIA. #	3" DIA. #	3 1/2" DIA. #	4" DIA. #	5" DIA. #
12"	120025	120030	120035	120040	120050
24"	240025	240030	240035	240040	240050
30"	300025	300030	300035	300040	-----
36"	360025	360030	360035	360040	360050
46"	480025	480030	480035	480040	480050

\*All extensions are expanded on one end

Chassis Applications | Midget | Sprint | Dirt Late Model | IMCA Mod. | Chassis | Street Stock | Stock Clip | 180° Crossover | Tractor/Derby  
Mufflers | Elbow Applications | Misc. | Turnouts & Extensions | X & Y Pipes | U & J Bends | Flanges/Gaskets | Collectors | Drag | 4 Cyl. | Dirt Mod.

## Exhaust System Applications

### 2 x 1 Collectors

INLET DIA.	3" OUT #	3 1/2" OUT #	4" OUT #	5" OUT #
3" I.D.	<b>Y3030</b>	<b>Y3035</b>	<b>Y3040</b>	<b>Y3050</b>
3 1/2" I.D.	-----	<b>Y3535</b>	<b>Y3540</b>	<b>Y3550</b>

### 2 x 2 Collectors

INLET DIA.	2 1/2" OUT #	3" OUT #	3 1/2" OUT #
2 1/2" I.D.	<b>X2525</b>	-----	-----
3" I.D.	-----	<b>X3030</b>	<b>X3035</b>
3 1/2" I.D.	-----	<b>X3530</b>	<b>X3535</b>



Right Side Elbow  
(See Chart Below)



Left Side Elbow  
(See Chart Below)



2x2 and 2x1 collectors are designed for easy muffler and tailpipe installation.

### H Pipes

INLET DIA.	3 1/2" OUT #
3 1/2" I.D.	<b>H3535</b>



### Tail Pipe Saver

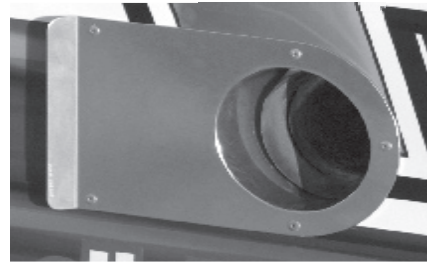

**New! Visit website for details**

Crossover style headers as listed on page 3.  
(Elbows, 2x2 and 2x1 collectors not included with headers.)

For Mufflers, See Page 46

HEADER STYLE	LEFT SIDE #	RIGHT SIDE #
134V, 134VH, 135, 135V-3, 135H, 335	<b>3042</b>	<b>3031</b>
135VY, 135VYCM, 335VY, 335VYE	<b>1-3045</b> <b>1-30310</b>	<b>1-30310</b>
135V, 135VH, 136, 136V, 136VH, 335V, 336	<b>3542</b>	<b>3531</b>
136V3YG	<b>35610</b>	<b>120035</b>
136V3Y, 336V3Y	<b>1-3545</b> <b>1-35310</b>	<b>1-35310</b>
145, 445	<b>3032</b>	<b>3031</b>
145V, 146, 146V, 445V, 446	<b>3532</b>	<b>3531</b>
179-1	<b>480030</b>	<b>480030</b>
179V-1, 180-1	<b>480035</b>	<b>480035</b>
179-2	<b>360030</b>	<b>360030</b>
179V-2, 180-2	<b>360035</b>	<b>360035</b>
D180, D180V, H180, H180V	<b>1-3535</b>	-----



## Mufflers

LENGTH	OUTLET DIAMETER	INLET DIAMETER	BODY DIAMETER	PART #
6"	3"	3"	3 1/2"	<b>63030</b>
8"	3"	3"	3 1/2"	<b>83030</b>
12"	3"	3"	3 1/2"	<b>123030</b>
6"	3 1/2"	3 1/2"	4"	<b>63535</b>
8"	3 1/2"	3 1/2"	4"	<b>83535</b>
8"	3 1/2"	4"	4"	<b>83540</b>
9"	3 1/2"	3 1/2"	4 3/8"	<b>92535</b>
10"	3 1/2"	3 1/2"	4"	<b>103535K</b>
12"	3 1/2"	3 1/2"	4"	<b>123535</b>
12"	3 1/2"	4"	4"	<b>123540</b>
12"	4"	4"	4"	<b>124040</b>
14"	3 1/2"	3 1/2"	4 1/2"	<b>14272535</b>
14"	3 1/2"	3 1/2"	4 1/2"	<b>14272735-78</b>
18"	3 1/2"	3 1/2"	4"	<b>183535</b>
24"	3 1/2"	3 1/2"	4"	<b>243535</b>
27"	4"	4"	4 1/2"	<b>273540</b>

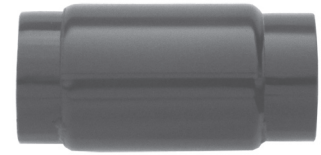

Temporary non-high temperature paint



**95 DB Muffler**  
At 4 pounds



LENGTH	WEIGHT	PART #	SANCTION APPROVED
11"	2.84#	<b>112535</b>	ALL-STAR - SUPRA
11"	2.35#	<b>112530</b>	-----
11"	2.40#	<b>113035</b>	-----
14"	4.00#	<b>14272735-78</b>	W.O.O - ASCS

## IMCA Mufflers

Temporary non-high temperature paint

LENGTH	WEIGHT	PART #	SANCTION APPROVED
6"	1.28#	<b>IMCA609</b>	IMCA
9"	1.95#	<b>IMCA930</b>	IMCA
9"	2.30#	<b>IMCA935</b>	IMCA

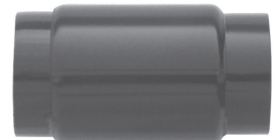

## Insert Reducer & Muffler

With it's straight through design, the Schoenfeld Insert Muffler reduces noise without excess back pressure. The insert is light weight with nothing to burn out.

### Reducers

### Mufflers

COLLECTOR DIAMETER	LONG	CORE DIAMETER	PART #
3"	4"	2 1/2"	<b>42530NH</b>
3 1/2"	4"	2 1/2"	<b>42535NH</b>
3 1/2"	4"	3"	<b>43035NH</b>
4"	4"	3 1/2"	<b>43540NH</b>

COLLECTOR DIAMETER	LENGTH	CORE DIAMETER	PART #
3"	4"	2 1/2"	<b>42530</b>
3 1/2"	4"	3"	<b>43035</b>
4"	4"	3 1/2"	<b>43540</b>
3 1/2"	24"	3"	<b>243035</b>
4"	24"	3"	<b>243040</b>
4"	24"	3 1/2"	<b>243540</b>
3 1/2"	30"	3"	<b>303035</b>
4"	30"	3"	<b>303040</b>
4"	30"	3 1/2"	<b>303540</b>

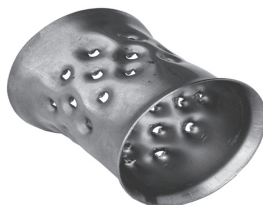
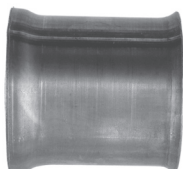

Chassis Applications Midget Sprint Dirt Late Model IMCA Mod. Chassis Street Stock Stock Clip 180° Crossover Collectors Drag 4 Cyl. Dirt Mod. Tractor/Derby Crossover Drag 4 Cyl. Dirt Mod. Mufflers Elbow Applications Misc. Turnouts & Extensions X & Y Pipes U & J Bends Flanges/Gaskets Collectors Drag 4 Cyl. Dirt Mod.

**NEW!**

## Anti-Reversion Chamber

**NEW!**

LENGTH	OUTLET DIAMETER	INLET DIAMETER	BODY DIAMETER	PART #
11"	3 1/2"	3"	4"	<b>112530AR</b>
11"	3 1/2"	3 1/2"	4"	<b>112735AR</b>

Temporary non-high temperature paint

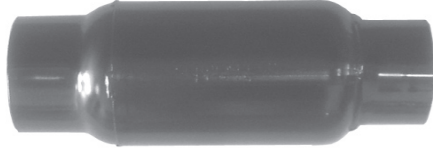

Tractor/Derby	Crossover	180° Crossover	Stock Clip	Street Stock	Chassis	IMCA Mod.	Dirt Late Model	Sprint	Midget	Chassis Applications
Dirt Mod.	4 Cyl. Drag	Collectors	Flanges/Gaskets	U & J Bends	X & Y Pipes	Turnouts & Extensions	Misc.	Elbow Applications	Mufflers	