



80-96 Ford F150 / Bronco 4WD
80-96 Ford F250 2WD
4"- 6" Suspension Lift
Installation Instructions

REQUIRED TOOL LIST:

- Safety Glasses
- Metric / Standard Wrenches & Sockets
- Floor Jack
- Jack Stands
- Measuring Tape
- Torque Wrench
- Drill & Assorted Drill Bits



Before beginning the installation, thoroughly & completely read these instructions & the enclosed driver's WARNING NOTICE. Affix the WARNING decal in the passenger compartment in clear view of all occupants. Please refer to the Parts List to insure that all parts & hardware are received prior to the disassembly of the vehicle.

Make sure you park the vehicle on a level concrete or asphalt surface. Many times a vehicle is not level (side-to-side) from the factory & is usually not noticed until a lift kit has been installed, which makes the difference more visible. Using a measuring tape, measure the front & rear (both sides) from the ground up to the center of the fender opening above the axle. Record this information below for future reference.

Driver Side Front: _____ Passenger Side Front: _____
 Driver Side Rear: _____ Passenger Side Rear: _____

IMPORTANT NOTES:

- This lift is determined from the amount of lift to the front of the vehicle, while only lifting the rear to a position level with the front.
- If larger tires (10% more than the stock diameter) are installed, speedometer recalibration will be necessary. Contact your local Ford dealer or an authorized dealer for details.
- After installation a qualified alignment facility is required to align the vehicle to the OEM specifications.

Kit Box Breakdown:

<u>Part#</u>	<u>Description</u>	<u>Qty.</u>	<u>Illustration #</u>
<u>184B, 184F2, 184P, 186B, 186F2, or 186P (*184BS, 184PS, 186BS, or 186PS)</u>			
LHB543-5	Left Axle Beam Pivot Bracket	1	2
RHB543-6	Right Axle Beam Pivot Bracket	1	3
LRB54-5	Left Radius Arm Bracket	1	1
RRB54-6	Right Radius Arm Bracket	1	1
HB-1846	Hdwr Bag (184B,186B,186P,184BS,184PS,186BS,& 186PS)	1	
HB-1846F2	Hdwr Bag (184F2 & 186F2)	1	
IF2846	Instruction Sheet	1	

184B

916X314X1112U	9/16 x 3 1/4 x 11 1/2 U-bolt	4	
RB35	3.5" Rear Block	2	

184F2

58X338X11U	5/8 x 3 3/8 x 11 U-bolt	4	
HS25	Hex-Cut Spacers 1/4"	2	
RB20	2" Rear Block	2	

184P

916X314X1112U	9/16 x 3 1/4 x 11 1/2 U-bolt	4	
RB20	2" Rear Block	2	

186B

916X314X1312U	9/16 x 3 1/4 x 13 1/2 U-bolt	4	
RB55	5.5" Rear Block	2	

186F2

58X338X13U	5/8 x 3 3/8 x 13 U-bolt	4	
HS25	Hex-Cut Spacers 1/4"	2	
RB35	3.5" Rear Block	2	

186P

916X314X1512U	9/16 x 3 1/4 x 15 1/2 U-bolt	4	
RB45	4.5" Rear Block	2	

NOTE: SYSTEMS with new rear springs do not include rear blocks.

HB-1846

Hardware Bag Breakdown:

916X312FTB	9/16 x 3 1/2" Fine Thread Bolt, Grade 8	1	
12X112FTB	1/2 x 1 1/2" Fine Thread Bolt, Grade 8	7	
716X112FTB	7/16 x 1 1/2" Fine Thread Bolt, Grade 8	13	
916FTN	9/16" Fine Thread Nut	9	
12FTN	1/2" Fine Thread Nut	7	
716FTN	7/16" Fine Thread Nut	13	
916SAEW	9/16" SAE Washer	2	
12SAEW	1/2" SAE Washer	14	
716SAEW	7/16" SAE Washer	16	
I-F80150			

HB-1846F2	Hardware Bag Breakdown:	
916X312FTB	9/16 x 3 1/2" Fine Thread Bolt, Grade 8	1
12X112FTB	1/2 x 1 1/2" Fine Thread Bolt, Grade 8	7
716X112FTB	7/16 x 1 1/2" Fine Thread Bolt, Grade 8	13
916FTN	9/16" Fine Thread Nut	1
12FTN	1/2" Fine Thread Nut	7
716FTN	7/16" Fine Thread Nut	13
916SAEW	9/16" SAE Washer	2
12SAEW	1/2" SAE Washer	14
716SAEW	7/16" SAE Washer	16
58FTN	5/18" Fine Thread Nut	8

Front Installation:

1. Block the rear tires / wheels of the vehicle in front & behind the tires. Raise the front of the vehicle with a floor jack & support the frame with jackstands. Remove the front tires / wheels & shock absorbers.
2. Separate the drag link assembly from the OEM pitman arm. If your vehicle is equipped with a front anti-sway bar, remove the brackets that hold it to the frame.
3. Mark the front driveshaft & the front differential yoke so that the driveshaft can be reconnected in its original position. **Note:** Failure to do so may result in a driveline imbalance & subsequent vibration. Disconnect the front driveshaft at the u-joint & tape the caps to prevent them from falling off. **Note:** Be very careful not to pull the rear end of the driveshaft forward out of its splines or damage may occur to the transfer case due to improper reinstallation. Secure the end of the driveshaft up & out of the way.
4. Disconnect both front brake lines at the calipers. **Note:** Save the crush washers as they will be reused if the OEM lines are reinstalled. Hang the open ends of the brake lines as high as possible to keep the fluid from draining out. Cover the open ends of the brake lines & calipers to prevent loose dirt from entering the braking system. Disconnect the vent hose from the front differential housing.

PERFORM STEPS 5 THROUGH 7 ON THE PASSENGER SIDE FIRST, THEN REPEAT THEM ON DRIVER SIDE.

5. Support the axle beam near the spindle with a floor jack. Support the beam at several points to prevent it from tipping or falling over. **Note:** The beam assemblies are very heavy so exercise caution when removing them to avoid any possibility of injury.
6. Remove the spring's lower retaining nut & washer, then remove the J-clip that holds the spring to the coil tower. Slowly lower the jack enough to remove the OEM coil spring.
7. Remove the center pivot bolt from the end of axle beam. Remove the nut from the end of the radius arm towards the rear of the vehicle & carefully lower the end of the beam to the floor. **Note:** Support the front differential with a floor jack. In order to keep the beam from tipping to one side or the other, you must either chain the beam to the floor jack or use a second jack to support the beam near the spindle.

REPEAT STEPS 5 THROUGH 7 ON THE DRIVERS SIDE.

8. If the vehicle is equipped with a power steering cooler line (located on front bumper side of front cross member), remove the two bolts that hold it to the front of the forward cross member. Gently move the cooler line out of the way.
9. Some of the brackets that held the pivot end of the front axle beams to the front cross member are bolted to the frame, some are riveted. These stock brackets must be removed from the cross member by unbolting or drilling out the rivet heads. A right angle drill may be necessary to drill some of the rivets. See rivet removal steps below.
Remove the rivets as follows:
 - Center punch rivet head
 - Drill 1/4" pilot hole in center of rivet approximately 1/4" deep
 - Drill rivet head off using a 7/16" bit, being careful not to drill into frame
 - Drive rivet out with a hammer & punch
10. Remove the brackets that held the radius arms to the frame. Again, any rivets will have to be drilled out to be removed. (See Illustration # 1)
11. To install the new radius arm drop brackets, locate the rearward hole of the two holes under the bottom of the frame. (See Illustration # 1) Now raise the brackets up to the frame & start a 7/16" x 1 1/2" bolt in the rearward hole under the bottom of the frame. Install it with the washer & nut on the inside of the frame. **Note:** Be sure the frame is slick & nothing is protruding through the frame between the bracket & the frame. The bracket must be flush against the frame prior to drilling.
12. Holding the bracket tightly against the frame, drill the four remaining 7/16" holes through the frame. (See Illustration # 1) **Note:** Before drilling holes, check the inside frame rail for any obstructions or line interference. It may be necessary to reroute lines on certain model vehicles if they interfere with the relocated mounting brackets. Use a wire brush to remove any undercoating. The bracket must be installed on a clean surface. Insert the three 7/16" bolts on the side of frame from the outside with a washer & nut on the inside of the frame. On the forward bottom hole, install the bolt from the inside of the frame with the washer & nut on the outside (bottom). Tighten all the bolts at this time.
13. Install the left axle beam pivot drop bracket, actually located on the passenger side of the cross member - to the front, # LHB543-5. (See Illustration # 2) The beam pivot drop bracket mounts on the inside of the cross member (in the OEM location). Locate the bracket onto the cross member using the OEM holes & hold them in place with some of the OEM hardware, but do not tighten.
14. Mark the new holes that are needed with a center punch. (See Illustration # 2) Remove the brackets & drill the necessary 7/16" & 1/2" holes. File any raised edges. Clean the surface of any undercoating, loose paint, etc. Install the axle beam pivot drop bracket with the specified hardware furnished using thread locking compound & torque per the Torque Specification Chart. (See Illustration # 2)

15. Reinstall the power steering cooler line, if equipped, using the OEM screw & clamp. However, make sure the lines do not rub or contact any of the bolts, bracket, or metal surfaces. It may be necessary to bend the lines or clamps slightly to clear any obstructions.
16. Install the passenger side axle beam pivot drop bracket (actually located on the driver side of cross member - to the rear, # RHB543-6). Locate the drop bracket onto the cross member. (See Illustration # 3) Mark the new holes that are needed with a center punch. (See Illustration # 3) Remove the brackets & drill the necessary 1/2" holes. File any raised edges. Clean the surface of any undercoating, loose paint, etc. Install the axle beam pivot drop bracket with the specified hardware furnished using thread locking compound & torque per the Torque Specification Chart. (See Illustration # 3)
17. Remove the OEM pitman arm from the steering box using a pitman arm puller. Failure to use the proper tool could result in damage to the steering mechanism. Install the pitman arm # FA400 (Ordered Separately) using its instructions. Torque the nut per the Torque Specification Chart. (**NOTE:** Pitman Arm # FA400 is for vehicles with Power Steering only).
18. Position the ends of the radius arms into the relocated brackets & install the OEM bushings & OEM hardware. Do not fully tighten yet.

NOTE: If you purchased the OPTIONAL frame support bar # FSB80, instead of using the OEM steel flat washer, install the new frame support bar with the flat side of the ends to the bottom & the rounded portion to the top (See Illustration # 4). Then install the nuts on the end of the radius arm, do not tighten.
19. Using the floor jack, raise & position one of the axle beams into the new drop bracket. Insert the existing pivot bolt through the bracket & axle beam & install the nut. (See Illustration # 2 & # 3) Do not tighten. Repeat this procedure on the other axle beam.
20. Check again, to make sure that all radius arm bushings & hardware is installed as was shown in Illustration # 1.
21. Reinstall the front driveshaft & torque the u-bolts.
22. With the floor jack still supporting the axle beam, lower the beam down enough to place the new coil into the spring seat. Install the spring's lower retaining washer & nut, then install the J-clip that holds the spring to the upper coil tower. Repeat this procedure on the other side.
Note: F250 Models ONLY, under each new coil spring install one of the hex-cut coil spring spacers (Part # HS25) over the OEM hex nut stud before installing the retaining washer & nut.
23. Install the appropriate length brake lines at this time (also available from SKYJACKER®). Bleed the brakes to remove any air from the lines according to the OEM recommendations. Reinstall the axle vent hose.
24. Re-install the anti-sway bar. SKYJACKER® offers sway bar lowering bracket kits (# SBL20 for 4" lifts & # SBL40 for 6" lifts).

25. Reconnect the drag link assembly to the pitman arm. Install the front shock absorbers & tires / wheels & lower the vehicle to the ground.
26. Cycle the steering left & right from lock to lock & check for any binding or interference. There should be a minimum of 1" of clearance between the tires & the radius arms at full lock. If there is less than 1", check to make sure you have the proper wheel offset & size. If necessary, the steering stop bolts may be adjusted out to 1.25", maximum.

REAR INSTALLATION:

27. Place a floor jack under the rear axle & raise the vehicle. Place jack stands under the frame to support the vehicle & remove the rear tires / wheels & shock absorbers.
28. Remove the axle u-bolts & lower the axle down a few inches. Care should be taken because when the u-bolts are removed, the axle can move freely.
29. **BLOCK INSTALLATION:** Place the new block (tallest end toward rear bumper) between the rear spring & OEM block or degree shim, if equipped. Raise the axle up being sure that the block pins are aligned & that the spring tie bolt is aligned in the block. Install & tighten the new rear u-bolts evenly (torque u-bolts 90-95 ft.lbs.). Install the rear shock absorbers, tires / wheels, remove jack stands, & lower the vehicle down to the ground.

F150:

Install the blocks, tall end toward the rear bumper, between the springs & the OEM blocks. (This means the new block will be installed on top of the OEM block.)

BRONCO:

Install the blocks, tall end toward the rear bumper, between springs & the OEM wedge.

30. **NEW SPRING INSTALLATION:** Remove the spring eye bolts & remove the OEM springs from the vehicle. Install the new springs with the long end of the spring toward the rear bumper (also thick end of the bottom wedge shim goes toward the rear bumper, if equipped).

F-150:

2" or 4" SYSTEMS with rear springs # FR52: Install the springs on top of the OEM blocks. (Some models may sit high in the rear as it did from the factory. If so, the OEM blocks may be removed to lower down the rear, if desired.)

4" SYSTEMS with rear springs # FR54: Install the springs on top of the OEM blocks (Some models may sit high in the rear as it did from the factory. If so, the OEM blocks may be removed to lower down the rear, if desired.)

6" SYSTEMS with new rear springs # FR54: Install the springs on top of the OEM blocks. (If you have the optional rear springs # FR56, remove the OEM blocks & install the springs on top of the axle.)

BRONCO:

On all SYSTEMS: Install the springs on top of the OEM wedge.

Final Notes:

- On models with a rear carrier bearing, if a driveshaft vibration is present, the carrier bearing or its cross member must be lowered.
- After the installation is complete, double check that all nuts & bolts are tight. Refer to the following chart below for the proper torque specifications. (Do not retighten the nuts & bolts where thread lock compound was used.)
- With the vehicle placed on the ground, cycle the steering lock to lock & inspect the steering, suspension, brake lines, front & rear drivelines, fuel lines, & wiring harnesses for proper operation, tightness, & adequate clearance.
- Have the headlights readjusted to the proper settings.
- Have a qualified alignment center realign the front end to the OEM specifications.
- Retorque all the bolts after the first 100 miles.

<u>TORQUE SPECIFICATIONS</u>					
<u>INCH SYSTEM</u>			<u>METRIC SYSTEM</u>		
Bolt Size	Grade 5	Grade 8	Bolt Size	Class 8.8	Class 10.9
5/16	15 FT LB	20 FT LB	6MM	5 FT LB	9 FT LB
3/8	30 FT LB	35 FT LB	8MM	18 FT LB	23 FT LB
7/16	45 FT LB	60 FT LB	10MM	32 FT LB	45 FT LB
1/2	65 FT LB	90 FT LB	12MM	55 FT LB	75 FT LB
9/16	95 FT LB	130 FT LB	14MM	85 FT LB	120 FT LB
5/8	135 FT LB	175 FT LB	16MM	130 FT LB	165 FT LB
3/4	185 FT LB	280 FT LB	18MM	170 FT LB	240 FT LB

- The above specifications are not to be used when the bolt is being installed with a bushing.

Seat Belts Save Lives, Please Wear Your Seat Belt.

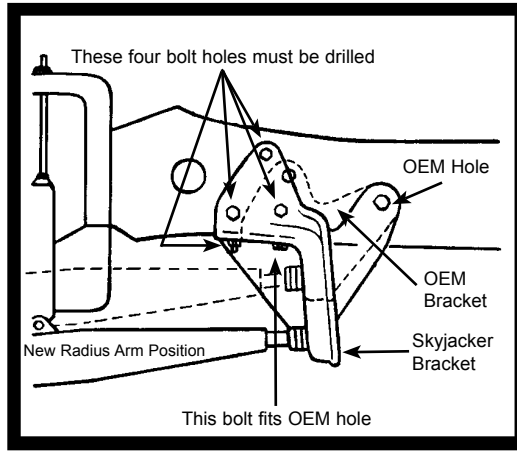

Illustration # 1

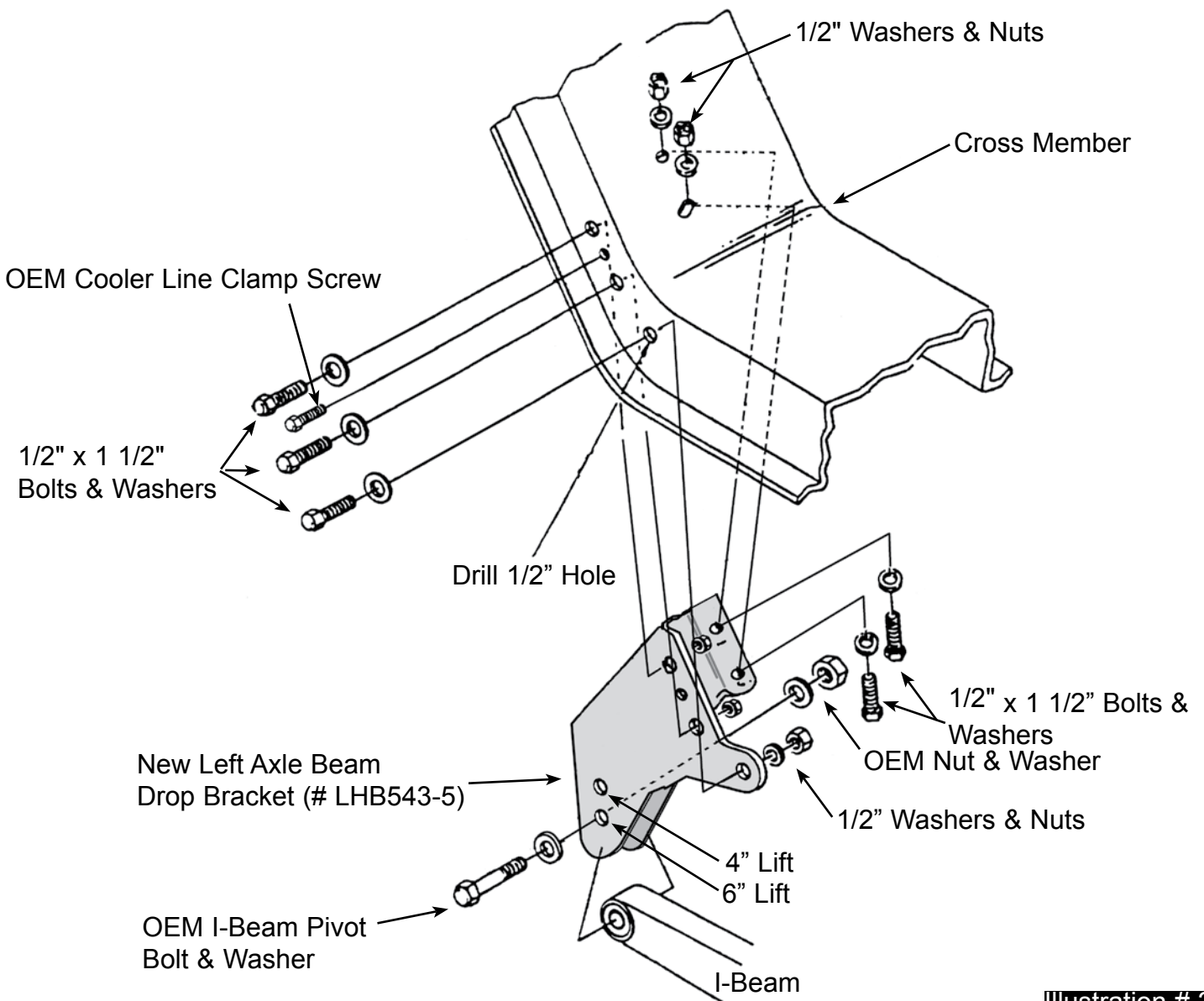

Illustration # 2

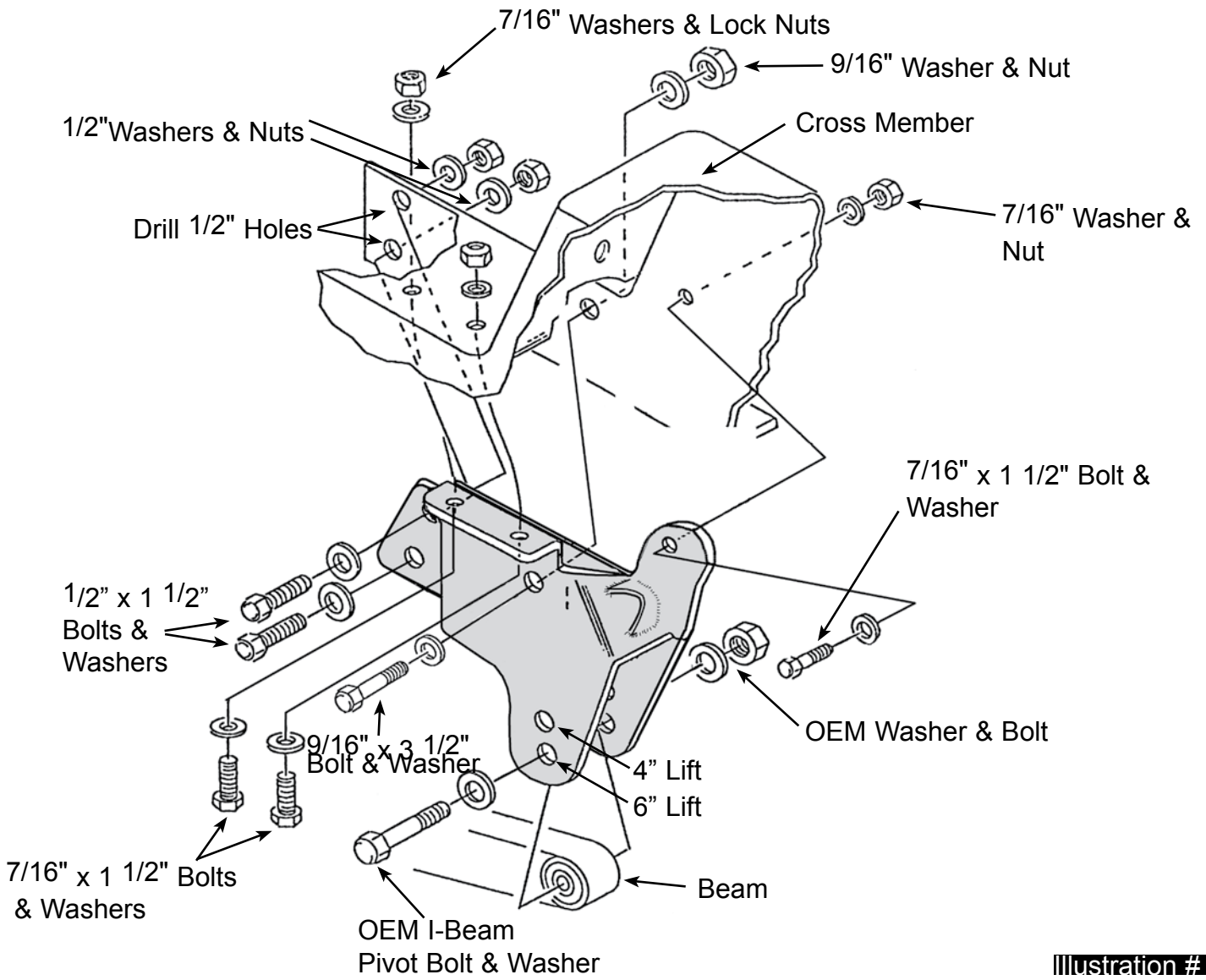

Illustration # 3

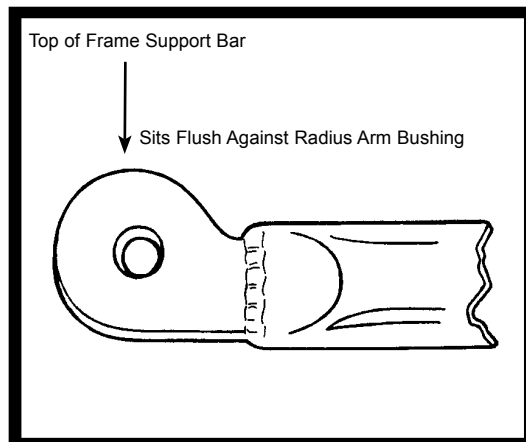

Illustration # 4