

4L80-E, 4L85-E

Line Pressure Booster Kit

Part No.
4L80E-LB1

- Large Ratio Boost Assembly
- Pressure Regulator Spring
- O-Rings (2)

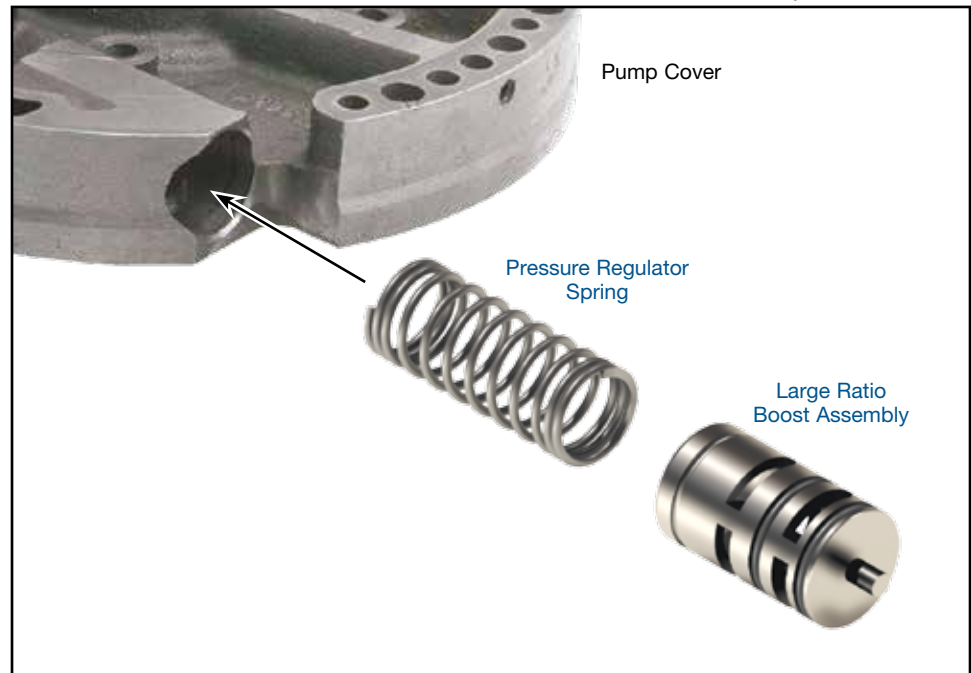

1. Disassembly

Remove and discard OE boost valve, sleeve, and large diameter pressure regulator spring. Retain OE pressure regulator valve, bumper spring, spring seat, end plug, and retaining clip.

2. Retrofit Modifications

Units with '89-'91 early pressure regulator valve design must be retrofitted. To retrofit, Sonnax boost valve and pressure regulator valve need to be shortened by grinding the ends (**Figure 1**).

3. Bore Preparation



NOTE: O-rings included in this kit provide extra insurance for preventing crossleaks and should always be installed.

- Carefully inspect snap ring grooves, feed holes or bore edges and de-burr if necessary to reduce possibility of cutting O-rings during installation. A non-abrasive tool such as a radial wire brush (**Figure 2**) works best, and the bore should always be thoroughly cleaned after any de-burring.
- Place O-rings into grooves on boost sleeve, roll sleeve over bench to resize O-rings, then pre-lube O-rings. Sonnax Slippery Stick™ (**O-LUBE**) or Door Ease® are ideal for this purpose.

4. Installation

- Install OE pressure regulator valve, small bumper spring (used 92-later), Sonnax pressure regulator spring, and OE spring seat.

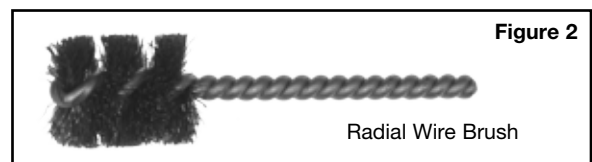
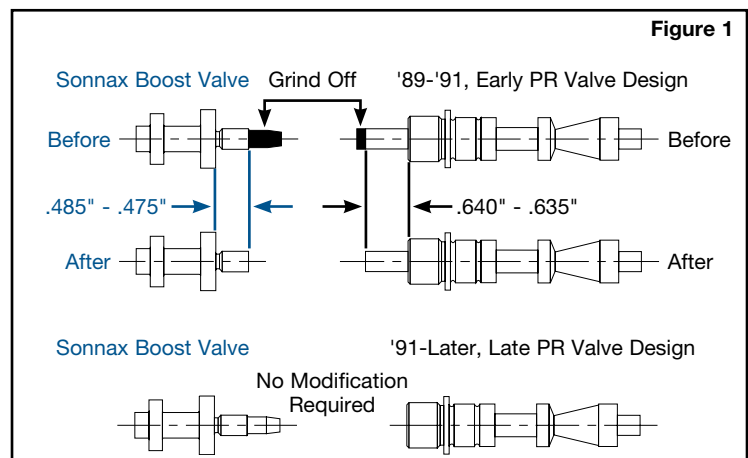

4. Installation (Continued)

- b. With open end toward the two springs, carefully push boost sleeve assembly into pump body, just deep enough to reinstall retaining ring.
- c. Install retaining ring into stator body.

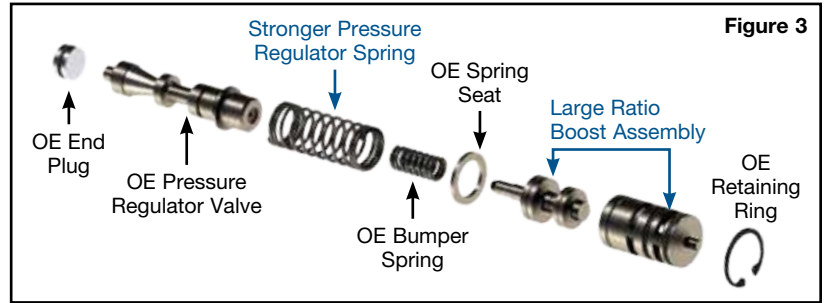

The Prescription for Optimum Pressure

Stronger pressure regulator springs raise pressure equal amounts at idle and maximum pressure. Many aftermarket “kit” springs are a compromise, raising pressure too much at idle and not enough at maximum pressures (A in graph). Larger boost valves, on the other hand, have a progressive effect on pressure, changing the rate of pressure increase (B in graph).

The Sonnax large ratio boost valves and stronger pressure regulator springs are designed to work together. This is an ideal combination: smooth engagements and lower load on the pump at idle, but a greater increase in pressure as the transmission is worked harder.

For a more in-depth look at raising line pressure, read *The Prescription for Optimum Pressure* in the Sonnax online technical library at www.sonnax.com.

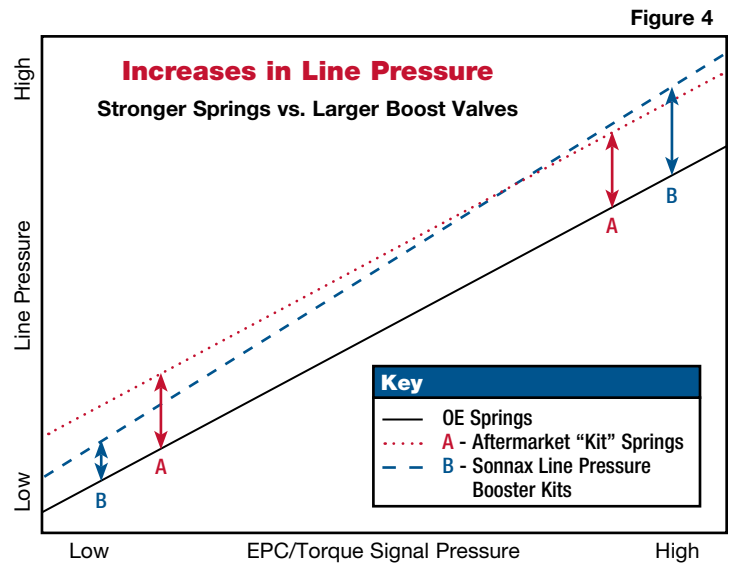

Pump Tech

Good Pressure Depends on a Good Pump

Verify Pump Specifications

Excess clearance equals low pump volume and pressure.

Gear Pocket Clearance	.0008" to .0028" Check with feeler gauge and straight edge over pump face, or with Plastigauge and bolt complete pump together.
Outer Gear to Pump Body	.005" max.

Perform Wet Air Test

Pump Housing Flatness	.001"
------------------------------	-------

It is a good idea to perform the wet air test again (Figure 5) after installing Sonnax line pressure booster kit. Continued leakage after replacing boost valve and sleeve indicates cross leakage between pump halves, which may be warped. Replace or resurface the pump halves to eliminate remaining leakage, or use Loctite #518 gasket eliminator on the circuit from feed to boost sleeve.

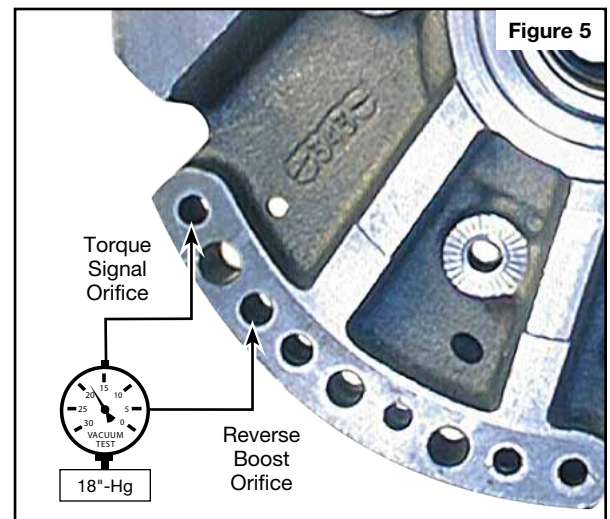

Pump Tech (continued)

Check for Wear

Wear on tips of inner gear teeth or on the crescent means low pressure. Inspect inside of crescent, area between suction and discharge ports and tips of gear teeth for wear. Wear and excess clearance reduces pump efficiency.

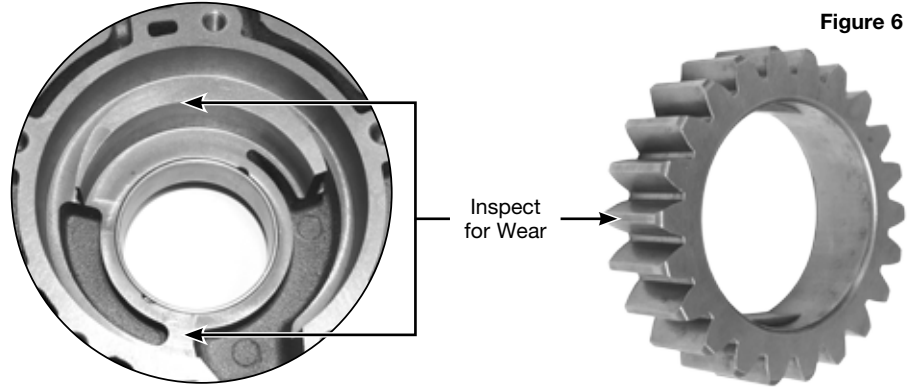

Figure 6

Shift Tech

For detailed information on drilling separator plate orifices, read *Drilling Orifices the Smart Way* in the Sonnax online technical library at www.sonnax.com.