



GHOST® SINGLE/DUAL SURFACE MOUNT LIGHT

Single Light:

- Black Housing: #EGHST2(x)-12
- Chrome Housing: #EGHST2(x)C-12
- White Housing: #EGHST2(x)W-12

Dual Light:

- Black Housing: #EGHST6(x)B-12
- Chrome Housing: #EGHST6(x)C-12
- White Housing: #EGHST6(x)W-12



Important Information:

- Warning devices are strictly regulated and governed by Federal, State and Municipal ordinances. These devices shall be used ONLY on approved vehicles. It is the sole responsibility of the user of these devices to ensure compliance.
- DO NOT install this product or route any wires in the Air Bag Deployment Zone. Refer to your vehicle Owner's Manual for the location of any air bag deployment zones.
- DO NOT connect this device to a strobe power supply. This product is self-contained and does not require an external power supply.

INSTALLATION:

Establish the mounting position on the vehicle. Use the gasket (included) as a template to drill three $\varnothing\frac{1}{2}$ " holes for the light wire and pilot holes for the mounting screws. Note: pilot holes are $4\frac{7}{8}$ " on center.

Caution: Do not stretch the mounting gasket as this may change the required hole spacing.

TECHNICAL SPECIFICATIONS	
Overall Dimensions:	
Single	5.65" L x 1.06" H x 1.8" D
Dual	5.5" L x 2.5" H x 1" D
Input Voltage:	10 - 16 Vdc
Current Consumption:	
Single	<1 amp
Dual	<2 amps
# of LEDs:	
Single	6 Generation 3 LEDs
Dual	12 Generation 3 LEDs
Operating Temperature:	-40° to +65° C
Flash Patterns:	33

OPERATION:

WIRE CONNECTIONS

See setup procedure on second page. The single GHOST® comes equipped with an internal flasher with 33 user selectable patterns that can be synchronized either alternating or simultaneous with up to three other lights. It can also be put into slave mode and driven through an external flasher.

1. Connect the GHOST BLACK wire to a good, convenient ground.
2. Connect the GHOST RED wire to one side of a user supplied on/off switch. Connect the other side of the switch, through a 5Amp fuse, to a source of +10 - 16 Vdc.

NOTE: The GHOST is a factory sealed unit that CANNOT be serviced in the field. Any attempt to gain access to the GHOST unit will most likely cause permanent damage and void its warranty.

WIRE HOOK-UP TABLE

WIRE COLOR:	CONNECT TO:
RED	+10 - 16 Vdc
BLACK	Ground (-)
WHITE	Pattern Select

WARNING

This product contains high intensity LED devices. To prevent eye damage, DO NOT stare into light beam at close range.

GHOST® SINGLE/DUAL SURFACE MOUNT LIGHT

NOTE: GHOST is equipped with Flash Pattern Recall. Once you have selected a pattern the light will always activate to that pattern every time the unit is turned on. Tape up and secure WHITE wire so that it will not accidentally change your selected pattern.

LIGHT SYNC CONFIGURATION INSTRUCTIONS

IMPORTANT! A MAXIMUM OF 2 DUAL LIGHTS CAN BE SYNCED.

- Set ID #:
 - Identify which pattern and sequence you want and look up ID # settings at left.
 - Connections
 - RED: +10 - 16 Vdc
 - WHITE: +10 - 16 Vdc
(Note: you will need to disconnect after power is applied)
 - BLACK: Ground
 - Apply power to unit
 - Without disconnecting power from unit, disconnect WHITE wire
 - Momentarily connect WHITE to Ground to change ID #
 - Identify ID # by number of sequential flashes
 - Possible ID #s: 1 – 4
 - Disconnect power from unit to get out of ID mode
- Set Flash Pattern:
 - Reapply power to units
 - Once all Light Head ID #s are configured, make sure all lights are flashing the same pattern.
 - Connect corresponding colored wires of all units together: RED to RED, etc.
 - To Change Flash Pattern:
 - Momentarily connect WHITE wires to Ground
 - Observe pattern change on all lights connected
 - Insulate all wires by taping with electrical tape
- Connect Master Switch:
 - IMPORTANT! Ensure WHITE Pattern/Sync Wires are tied together

SLAVE MODE

GHOST Surface Mount is capable of being activated through the use of a user supplied flasher by putting it in Slave Mode.

- Permanently connect the WHITE and BLACK wires to a good, convenient ground.
- Connect the RED wire, through a 5 Amp fuse, to the output of a +10 - 16 Vdc switching flasher.

1 (one) LIGHT

Follow the Light Sync Configuration Instructions and set the GHOST light to the following ID:

- Alternating (default): ID #1 or ID #3 (includes cycle patterns and steady burn patterns)
- Simultaneous: ID #2 or ID #4 (both lights will flash together regardless of pattern)

2 (two) LIGHTS

Follow the Light Sync Configuration Instructions and set the GHOST lights to the following ID:

IMPORTANT: Make sure both lights flash the same pattern!

- Both assemblies simultaneous with individual lights alternating.
 - Example: Driver/Passenger sim; Dr.(left alt right) Pass.(left alt right)
 - Set both GHOST Assemblies to ID #1
- Both assys. alternating with individual lights alternating.
 - EX: Dr./Pass. alt; Dr.(left. alt. right.) Pass.(right alt. left)
 - Set one GHOST to ID #1 and the other to ID #3
- Both assys. alternating with individual lights simultaneous
 - EX: Dr./Pass. alt; Dr.(left sim left) Pass.(right sim right)
 - Set one GHOST to ID #2 and the other to ID #4
- Both assys. simultaneous with individual lights simultaneous.
 - EX: Dr./Dr. sim; Dr.(left sim left) Pass.(right sim right)
 - Set both GHOST housings to ID #2

X-PATTERN - To obtain X-Patterns, follow the ID SELECTION steps and set one of the four GHOST lights to ID #1, one to ID #2, one to ID #3, and one to ID #4. Then proceed to the PATTERN SELECTION steps.

NOTE: Be sure to mount each GHOST in the correct placement based on ID#.

PATTERN SELECTION

- Disconnect WHITE wire from any connections if applicable.
- Turn GHOST ON.
- Momentarily touching and removing the WHITE wire(s) to ground will advance the GHOST to the next flash pattern. Touching and removing the White wire for more than a few seconds will allow you to change the GHOST to the previous pattern. See flash pattern table. Continuing to touch and remove the WHITE wire(s) to ground will allow you to scroll through the pattern list. After pattern #33 is reached the list will start over again at pattern #1.

X-PATTERN SEQUENCE X-PATTERN LIGHT HEAD PLACEMENT

ID#1>ID#4>ID#2>ID#3

ID#4	ID#2
ID#3	ID#1

PATTERN RESET

- Remove power
- Place WHITE (sync) wire to ground
- With sync wire grounded, re-power RED wire
- Maintain for one second (light will dim)
- Remove power and ground (pattern 1 set)

Flash Patterns

Flash Pattern Name	1 Light	2 Lights Alternating	2 Lights Simultaneous	4 Lights X-Pattern	Flashes per Minute (FPM)
1. Quint	x	x	x		70
2. Warp	x	x	x		350
3. Inter-Cycle Flash	x	x			
4. Double Flash	x	x	x		70
5. Quad Flash	x	x	x		80
6. PowerPulse	x	x	x		180
7. RoadRunner	x	x	x		113
8. Q-Switch	x	x			
9. RoadRunner Steady Burn	x	x			113
10. Quad Steady Burn	x	x			80
11. E-Ideal Single Flash	x	x	x		200
12. E-Ideal Double Flash	x	x	x		146
13. Quad2 Flash	x	x	x		67
14. Double2 Flash	x	x	x		95
15. X-Warp				x	
16. X-Double				x	
17. PowerRunner	x	x	x		
18. LCR Quint	x	x	x		
19. Warp ³	x	x	x		
20. Ultra Warp	x	x	x		545
21. Thunder & Lightning	x	x			
22. Lite Speed	x	x	x		85
23. SuperSonic	x		x		170
24. LCR Lite Speed	x	x	x		
25. SuperSonic Ultra	x	x	x		
26. Tempo Shift	x	x	x		
27. Tempo Shift Warp	x	x	x		
28. SBE2	x	x	x		67
29. C ²	x	x	x		200
30. U ²	x	x	x		176
31. Ultra Glow	x	x	x		
32. Cyclone	x	x	x		
33. Chameleon	x	x	x		

GHOST®

GHOST® SINGLE/DUAL SURFACE MOUNT LIGHT

Single Light:

- Black Housing: #EGHST2(x)
- Chrome Housing: #EGHST2(x)C
- White Housing: #EGHST2(x)W

Dual Light:

- Black Housing: #EGHST6(x)B
- Chrome Housing: #EGHST6(x)C
- White Housing: #EGHST6(x)W



Important Information:

- Warning devices are strictly regulated and governed by Federal, State and Municipal ordinances. These devices shall be used ONLY on approved vehicles. It is the sole responsibility of the user of these devices to ensure compliance.
- DO NOT install this product or route any wires in the Air Bag Deployment Zone. Refer to your vehicle Owner's Manual for the location of any air bag deployment zones.
- DO NOT connect this device to a strobe power supply. This product is self-contained and does not require an external power supply.

INSTALLATION:

Establish the mounting position on the vehicle. Use the gasket (included) as a template to drill three $\varnothing\frac{1}{2}$ " holes for the light wire and pilot holes for the mounting screws. Note: pilot holes are $4\frac{7}{8}$ " on center.

Caution: Do not stretch the mounting gasket as this may change the required hole spacing.

TECHNICAL SPECIFICATIONS

Overall Dimensions:	
Single	5.65" L x 1.06" H x 1.8" D
Dual	5.5" L x 2.5" H x 1" D
Input Voltage:	10 - 30 Vdc
Current Consumption:	
Single	<1 amp
Dual	<2 amps
# of LEDs:	
Single	6 Generation 3 LEDs
Dual	12 Generation 3 LEDs
Operating Temperature:	-40° to +65° C
Flash Patterns:	33

OPERATION:

WIRE CONNECTIONS

See setup procedure on second page. The single GHOST® comes equipped with an internal flasher with 33 user selectable patterns that can be synchronized either alternating or simultaneous with up to three other lights. It can also be put into slave mode and driven through an external flasher.

1. Connect the GHOST BLACK wire to a good, convenient ground.
2. Connect the GHOST RED wire to one side of a user supplied on/off switch. Connect the other side of the switch, through a 5Amp fuse, to a source of +10 - 30 Vdc.

NOTE: The GHOST is a factory sealed unit that CANNOT be serviced in the field. Any attempt to gain access to the GHOST unit will most likely cause permanent damage and void its warranty.

WIRE HOOK-UP TABLE

WIRE COLOR:	CONNECT TO:
RED	+10 - 30 Vdc
BLACK	Ground (-)
WHITE	Pattern Select

⚠ WARNING

This product contains high intensity LED devices. To prevent eye damage, DO NOT stare into light beam at close range.

GHOST® SINGLE/DUAL SURFACE MOUNT LIGHT

NOTE: GHOST is equipped with Flash Pattern Recall. Once you have selected a pattern the light will always activate to that pattern every time the unit is turned on. Tape up and secure WHITE wire so that it will not accidentally change your selected pattern.

LIGHT SYNC CONFIGURATION INSTRUCTIONS

IMPORTANT! A MAXIMUM OF 2 DUAL LIGHTS CAN BE SYNCED.

1. Set ID #:
 - a. Identify which pattern and sequence you want and look up ID # settings at left.
 - b. Connections
 - i. RED: +10 - 30 Vdc
 - ii. WHITE: +10 - 30 Vdc
(Note: you will need to disconnect after power is applied)
 - iii. BLACK: Ground
 - c. Apply power to unit
 - d. Without disconnecting power from unit, disconnect WHITE wire
 - e. Momentarily connect WHITE to Ground to change ID #
 - i. Identify ID # by number of sequential flashes
 - ii. Possible ID #s: 1 – 4
 - f. Disconnect power from unit to get out of ID mode
2. Set Flash Pattern:
 - a. Reapply power to units
 - b. Once all Light Head ID #s are configured, make sure all lights are flashing the same pattern.
 - c. Connect corresponding colored wires of all units together: RED to RED, etc.
 - d. To Change Flash Pattern:
 - i. Momentarily connect WHITE wires to Ground
 - ii. Observe pattern change on all lights connected
 - e. Insulate all wires by taping with electrical tape
3. Connect Master Switch:
 - a. IMPORTANT! Ensure WHITE Pattern/Sync Wires are tied together

SLAVE MODE

GHOST Surface Mount is capable of being activated through the use of a user supplied flasher by putting it in Slave Mode.

1. Permanently connect the WHITE and BLACK wires to a good, convenient ground.
2. Connect the RED wire, through a 5 Amp fuse, to the output of a +10 - 30 Vdc switching flasher.

1 (one) LIGHT

Follow the Light Sync Configuration Instructions and set the GHOST light to the following ID:

- Alternating (default): ID #1 or ID #3 (includes cycle patterns and steady burn patterns)
- Simultaneous: ID #2 or ID #4 (both lights will flash together regardless of pattern)

2 (two) LIGHTS

Follow the Light Sync Configuration Instructions and set the GHOST lights to the following ID:

IMPORTANT: Make sure both lights flash the same pattern!

- Both assemblies simultaneous with individual lights alternating.
 - Example: Driver/Passenger sim; Dr.(left alt right) Pass.(left alt right)
 - Set both GHOST Assemblies to ID #1
- Both assys. alternating with individual lights alternating.
 - EX: Dr./Pass. alt; Dr.(left. alt. right.) Pass.(right alt. left)
 - Set one GHOST to ID #1 and the other to ID #3
- Both assys. alternating with individual lights simultaneous
 - EX: Dr./Pass. alt; Dr.(left sim left) Pass.(right sim right)
 - Set one GHOST to ID #2 and the other to ID #4
- Both assys. simultaneous with individual lights simultaneous.
 - EX: Dr./Dr. sim; Dr.(left sim left) Pass.(right sim right)
 - Set both GHOST housings to ID #2

X-PATTERN - To obtain X-Patterns, follow the ID SELECTION steps and set one of the four GHOST lights to ID #1, one to ID #2, one to ID #3, and one to ID #4. Then proceed to the PATTERN SELECTION steps.

NOTE: Be sure to mount each GHOST in the correct placement based on ID#.

PATTERN SELECTION

1. Disconnect WHITE wire from any connections if applicable.
2. Turn GHOST ON.
3. Momentarily touching and removing the WHITE wire(s) to ground will advance the GHOST to the next flash pattern. Touching and removing the White wire for more than a few seconds will allow you to change the GHOST to the previous pattern. See flash pattern table. Continuing to touch and remove the WHITE wire(s) to ground will allow you to scroll through the pattern list. After pattern #33 is reached the list will start over again at pattern #1.

X-PATTERN SEQUENCE X-PATTERN LIGHT HEAD PLACEMENT

ID#1>ID#4>ID#2>ID#3

ID#4	ID#2
ID#3	ID#1

PATTERN RESET

1. Remove power
2. Place WHITE (sync) wire to ground
3. With sync wire grounded, re-power RED wire
4. Maintain for one second (light will dim)
5. Remove power and ground (pattern 1 set)

Flash Patterns

Flash Pattern Name	1 Light	2 Lights Alternating	2 Lights Simultaneous	4 Lights X-Pattern	Flashes per Minute (FPM)
1. Quint	x	x	x		70
2. Warp	x	x	x		350
3. Inter-Cycle Flash	x	x			
4. Double Flash	x	x	x		70
5. Quad Flash	x	x	x		80
6. PowerPulse	x	x	x		180
7. RoadRunner	x	x	x		113
8. Q-Switch	x	x			
9. RoadRunner Steady Burn	x	x			113
10. Quad Steady Burn	x	x			80
11. E-Ideal Single Flash	x	x	x		200
12. E-Ideal Double Flash	x	x	x		146
13. Quad2 Flash	x	x	x		67
14. Double2 Flash	x	x	x		95
15. X-Warp				x	
16. X-Double				x	
17. PowerRunner	x	x	x		
18. LCR Quint	x	x	x		
19. Warp ³	x	x	x		
20. Ultra Warp	x	x	x		545
21. Thunder & Lightning	x	x			
22. Lite Speed	x	x	x		85
23. SuperSonic	x		x		170
24. LCR Lite Speed	x	x	x		
25. SuperSonic Ultra	x	x	x		
26. Tempo Shift	x	x	x		
27. Tempo Shift Warp	x	x	x		
28. SBE2	x	x	x		67
29. C ²	x	x	x		200
30. U ²	x	x	x		176
31. Ultra Glow	x	x	x		
32. Cyclone	x	x	x		
33. Chameleon	x	x	x		

HEADLIGHT TEMPLATE

2016+ FORD UTILITY NFORCE FIT/ GHOST

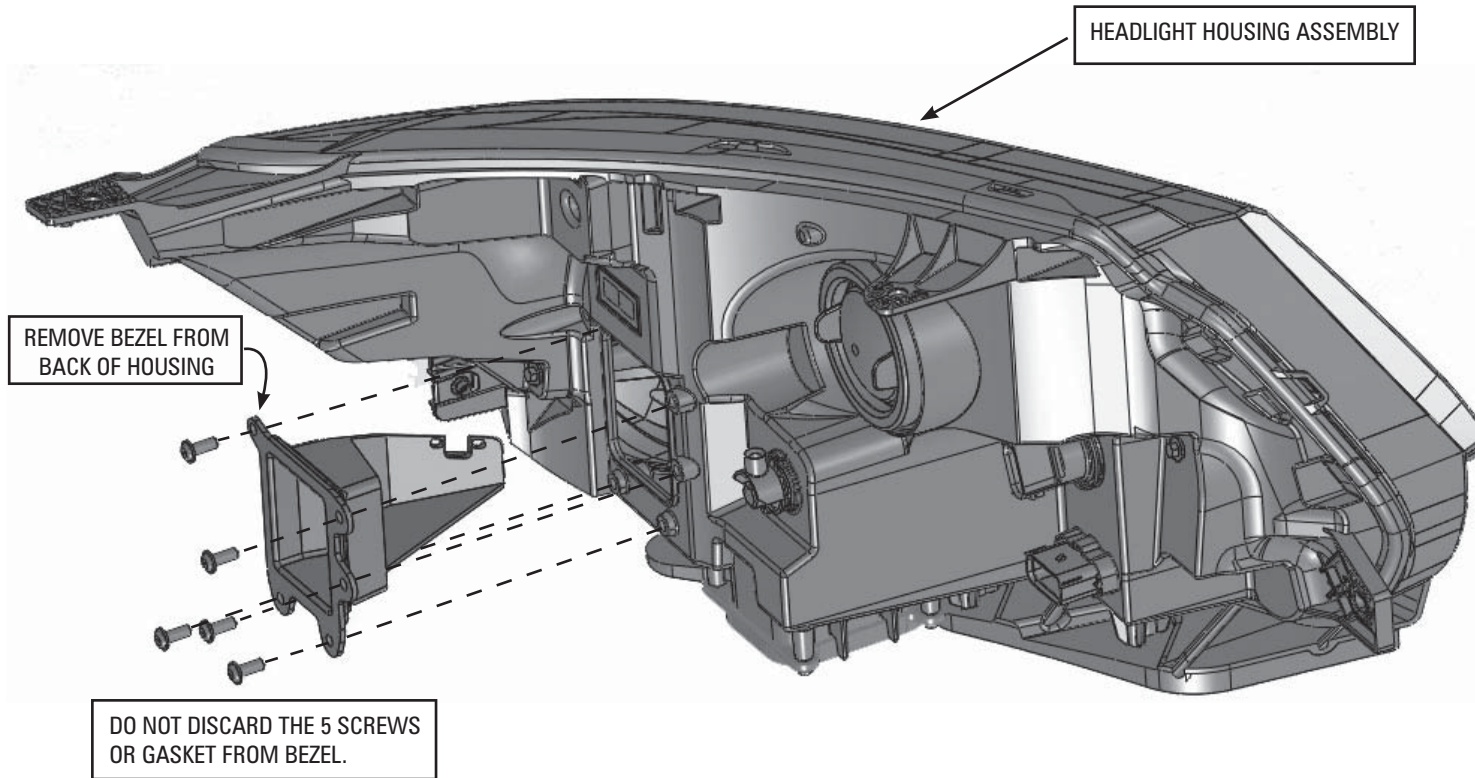

INSTRUCTIONS:

1. For ease of installation, remove both driver and passenger side headlights following the recommended manufacturers method.
2. Remove the 5 screws from back of headlight housing, as show.
3. Once the bezel has been removed from headlight housing, remove the tab noted on page 2.
4. Cut out the paper template and locate on bezel. Drill the holes, notch the wire slot that are associated with the purchased light.

NOTE:

To mount the nForce Fit light to headlight bezel, use two 4-40 x 5/16 long screws.

HEADLIGHT TEMPLATE

2016+ FORD UTILITY
NFORCE FIT/ GHOST

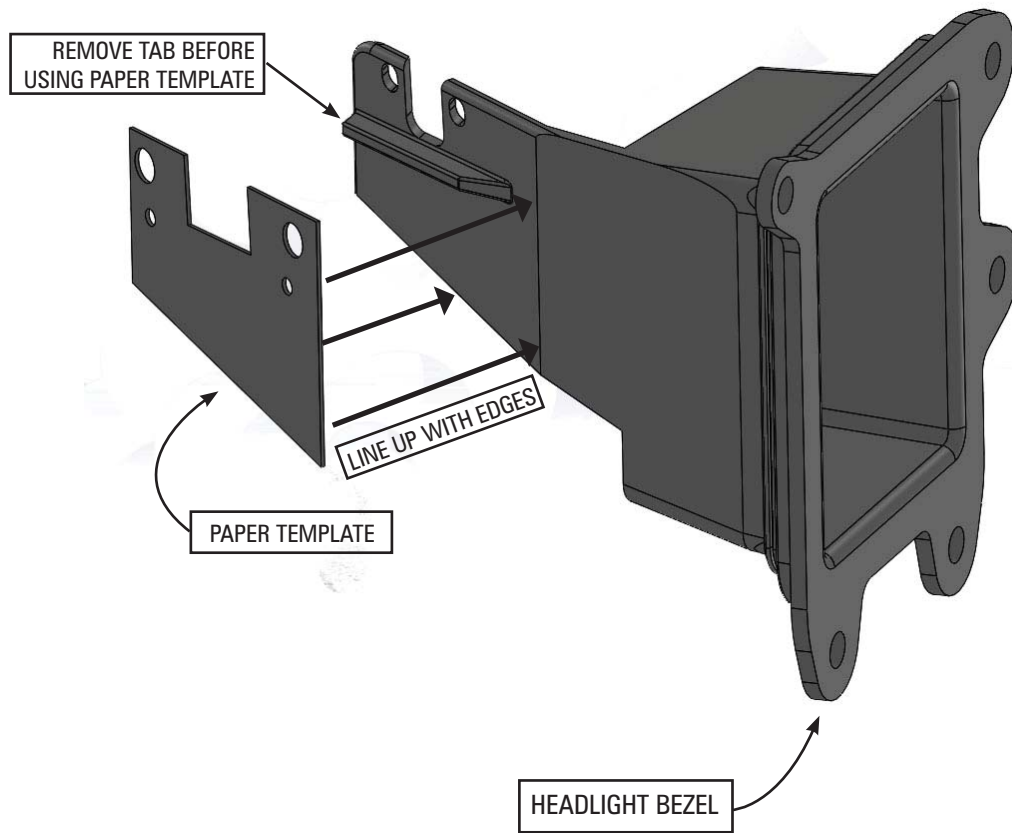

Template

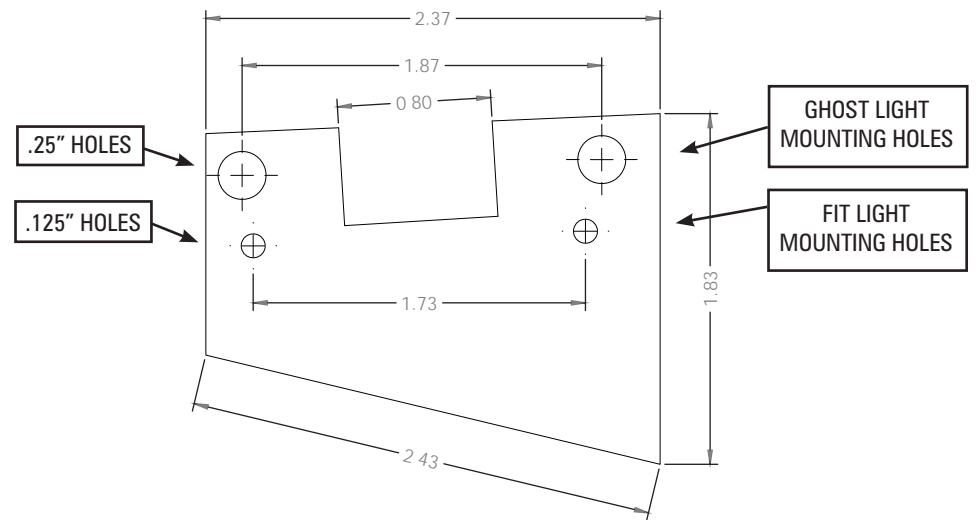

IMPORTANT:
TEMPLATE MAY NOT BE TO SCALE. SET THE PRINTER SETTINGS TO "ACTUAL SIZE".
VERIFY DIMENSIONS AFTER PRINTING.

GHOST®

GHOST® SINGLE SURFACE MOUNT LIGHT W/ PERMANENT MOUNT BRACKET

EGHST4(x)B-12 - Black

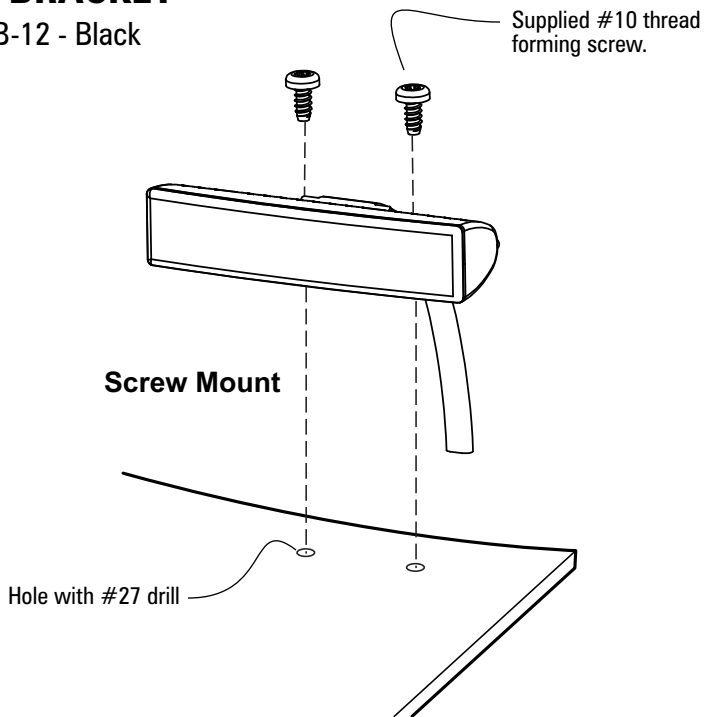

Important Information:

- DO NOT install this product or route any wires in the Air Bag Deployment Zone. Refer to your vehicle Owner's Manual for the location of any air bag deployment zones.
- DO NOT connect this device to a strobe power supply. This product is self-contained and does not require an external power supply.

INSTALLATION:

WARNING! This product contains high intensity LED devices. To prevent eye damage, **DO NOT** stare into light beam at close range.

1. **Screw Mount** - Establish a position on the vehicle. Use the mounting slots as a template to mark hole locations. Drill a hole using a #27 drill bit. The Torx screws provided are self-tapping.
2. Loosen the two #10 TORX screws on the back of each housing to adjust the angle of the GHOST. After adjustment, tighten the TORX screws.

TECHNICAL SPECIFICATIONS

Overall Dimensions:	4.0"L x 0.88"H x 1.75"D
Input Voltage Range:	10-16Vdc
Current Consumption:	0.75A / Module*
# of LEDs:	6 Generation 3 LEDs
Operating Temperature:	-20° to +65° C
Light Sync Technology:	Yes

*Pattern Dependent

OPERATION:

WIRE CONNECTIONS

See setup procedure on second page. The single GHOST comes equipped with an internal flasher with 33 user selectable patterns that can be synchronized either alternating or simultaneous with up to three other lights. It can also be put into slave mode and driven through an external flasher.

1. Connect the GHOST BLACK wire to a good, convenient ground.
2. Connect the GHOST RED wire to one side of a user supplied on/off switch. Connect the other side of the switch, through a 5Amp fuse, to a source of +10-16Vdc.

NOTE: The GHOST is a factory sealed unit that CANNOT be serviced in the field. Any attempt to gain access to the GHOST™ unit will most likely cause permanent damage and void its warranty.

1 SINGLE LIGHT

Follow the ID selection steps and set the GHOST to the following ID:
- Alternating (default): ID#1 or ID#3. (includes cycle patterns and steady burn patterns)
- Simultaneous: ID#2 or ID#4. (both lights will flash together regardless of pattern)

(Continued on opposite side)

WARNING

This product contains high intensity LED devices. To prevent eye damage, **DO NOT** stare into light beam at close range.



GHOST® SINGLE SURFACE MOUNT LIGHT W/ PERMANENT MOUNT BRACKET

EGHST4(x)B-12 - Black

2 SINGLE LIGHTS

Follow the ID selection steps and set the GHOST to the following ID:

IMPORTANT: Make sure both lights flash the same pattern!

- Both assemblies simultaneous with individual lights alternating.
 - Example: Driver/Passenger sim; Dr. (left alt right) Pass. (left alt right)
 - Set both GHOST Assemblies to ID#1
- Both assys. alternating with individual lights alternating.
 - EX: Dr./Pass. alt; Dr. (left. alt. right.) Pass. (right alt. left)
 - Set one GHOST to ID#1 and the other to ID#3
- Both assys. alternating with individual lights simultaneous
 - EX: Dr./Pass. alt; Dr. (left sim left) Pass. (right sim right)
 - Set one GHOST to ID#2 and the other to ID#4
- Both assys. simultaneous with individual lights simultaneous.
 - EX: Dr./Dr. sim; Dr. (left sim left) Pass. (right sim right)
 - Set both Ghost housings to ID#2

X-PATTERN - To obtain X-Patterns, follow the ID SELECTION steps and set one of the four GHOST lights to ID#1, one to ID#2, one to ID#3, and one to ID#4. Then proceed to the PATTERN SELECTION steps.

NOTE: Be sure to mount each GHOST in the correct placement based on ID#.

PATTERN SELECTION

1. Disconnect WHITE wire from any connections if applicable.
2. Turn GHOST ON.
3. Momentarily touching and removing the WHITE wire(s) to ground will advance the GHOST to the next flash pattern. Touching and removing the White wire for more than a few seconds will allow you to change the GHOST to the previous pattern. See flash pattern table. Continuing to touch and remove the WHITE wire(s) to ground will allow you to scroll through the pattern list. After pattern #33 is reached the list will start over again at pattern #1.

X-Pattern Sequence

ID#1 > ID#4 > ID#2 > ID#3

X-Pattern Light Head Placement

ID#4	ID#2
ID#3	ID#1

NOTE: The GHOST is equipped with flash pattern memory. Once you have selected a pattern the GHOST will always activate to that pattern every time the unit is turned on. Tape up and secure WHITE wire so that it will not accidentally change your selected pattern.

Ghost Sync Configuration Instructions
IMPORTANT! A MAXIMUM OF 4 SINGLE LIGHTS CAN BE SYNCED TOGETHER

1. Set ID#
 - a. Identify which pattern and sequence you want and look up ID# settings at left.
 - b. Connections
 - i. RED: +10-16Vdc
 - ii. WHT: +10-16Vdc (Note: you will need to disconnect after power is applied)
 - iii. BLK: Ground
 - c. Apply power to unit
 - d. Without disconnecting power from unit, disconnect WHT wire
 - e. Momentarily connect WHT to Ground to change ID #
 - i. Identify ID# by number of sequential flashes
 - ii. Possible ID#s: 1 – 4
 - f. Disconnect power from unit to get out of ID mode.
2. Set Pattern
 - a. Reapply power to units.
 - b. Once all Light Head ID#s are configured, make sure all lights are flashing the same pattern.
 - c. Connect corresponding colored wires of all units together: RED to RED, etc.
 - d. Change Pattern
 - i. Momentarily connect WHT wires to Ground
 - ii. Observe pattern change on all lights connected
 - e. Insulate all wires by taping with electrical tape
3. Connect Master Switch for Application
 - a. **IMPORTANT!** Ensure WHT Pattern/Sync Wires are tied together

PATTERN RESET

1. Remove power
2. Place WHITE (sync) wire to ground
3. With sync wire grounded, re-power RED wire
4. Maintain for one second (light will dim)
5. Remove power and ground (pattern 1 set)

SLAVE MODE

The GHOST is capable of being activated through the use of a user supplied flasher by putting it in slave mode.

1. Permanently connect the GHOST WHITE and BLACK wire to a good, convenient ground.
2. Connect the GHOST RED wire, through a 5Amp fuse, to the output of a +10-16Vdc switching flasher.

Flash Patterns

Pattern Name	1 Light	Alternating 2 Lights	Simultaneous 2 Lights	X-Pattern 4 Lights	F.P.M. (Flashes / Minute)
1. Quint	x	x	x		70
2. Warp	x	x	x		350
3. Inter-Cycle Flash	x	x			
4. Double Flash	x	x	x		70
5. Quad Flash	x	x	x		80
6. PowerPulse	x	x	x		180
7. RoadRunner	x	x	x		113
8. Q-Switch	x	x			
9. RoadRunner Steady Burn	x	x			113
10. Quad Steady Burn	x	x			80
11. E-Ideal Single Flash	x	x	x		200
12. E-Ideal Double Flash	x	x	x		146
13. Quad2 Flash	x	x	x		67
14. Double2 Flash	x	x	x		95
15. X-Warp				x	
16. X-Double				x	
17. PowerRunner	x	x	x		
18. LCR Quint	x	x	x		
19. Warp?	x	x	x		
20. Ultra Warp	x	x	x		545
21. Thunder & Lightning	x	x			
22. Lite Speed	x	x	x		85
23. SuperSonic	x		x		170
24. LCR Lite Speed	x	x	x		
25. SuperSonic Ultra	x	x	x		
26. Tempo Shift	x	x	x		
27. Tempo Shift Warp	x	x	x		
28. SBE2	x	x	x		67
29. C?	x	x	x		200
30. U?	x	x	x		176
31. Ultra Glow	x	x	x		
32. Cyclone	x	x	x		
33. Chameleon	x	x	x		

GHOST®

GHOST® SINGLE SURFACE MOUNT LIGHT W/ PERMANENT MOUNT BRACKET

EGHST4(x)B - Black

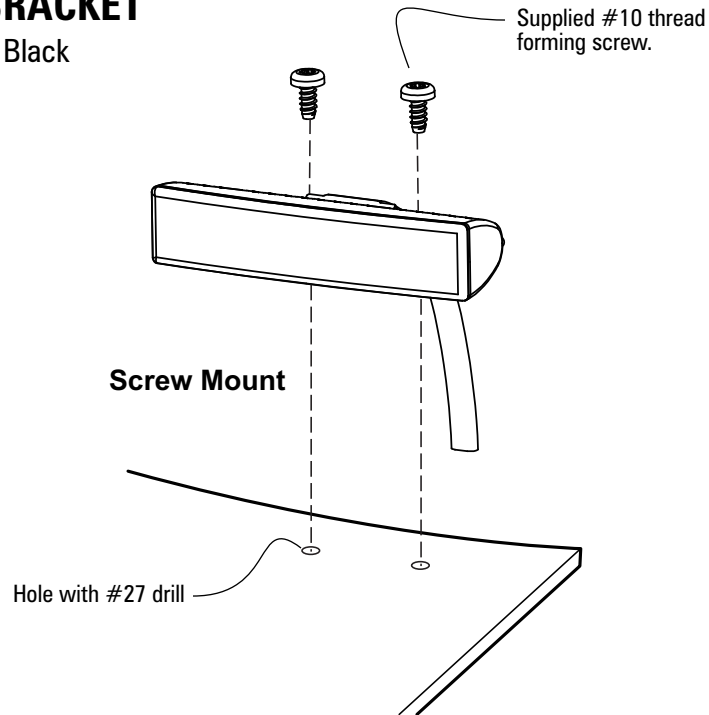

Important Information:

- DO NOT install this product or route any wires in the Air Bag Deployment Zone. Refer to your vehicle Owner's Manual for the location of any air bag deployment zones.
- DO NOT connect this device to a strobe power supply. This product is self-contained and does not require an external power supply.

INSTALLATION:

WARNING! This product contains high intensity LED devices. To prevent eye damage, **DO NOT** stare into light beam at close range.

1. **Screw Mount** - Establish a position on the vehicle. Use the mounting slots as a template to mark hole locations. Drill a hole using a #27 drill bit. The Torx screws provided are self-tapping.
2. Loosen the two #10 TORX screws on the back of each housing to adjust the angle of the GHOST. After adjustment, tighten the TORX screws.

TECHNICAL SPECIFICATIONS

Overall Dimensions:	4.0"L x 0.88"H x 1.75"D
Input Voltage Range:	10-30Vdc
Current Consumption:	0.75A / Module*
# of LEDs:	6 Generation 3 LEDs
Operating Temperature:	-20° to +65° C
Light Sync Technology:	Yes

*Pattern Dependent

OPERATION:

WIRE CONNECTIONS

See setup procedure on second page.

The single GHOST comes equipped with an internal flasher with 33 user selectable patterns that can be synchronized either alternating or simultaneous with up to three other lights. It can also be put into slave mode and driven through an external flasher.

1. Connect the GHOST BLACK wire to a good, convenient ground.
2. Connect the GHOST RED wire to one side of a user supplied on/off switch. Connect the other side of the switch, through a 5Amp fuse, to a source of +10-30Vdc.

NOTE: The GHOST™ is a factory sealed unit that CANNOT be serviced in the field. Any attempt to gain access to the GHOST™ unit will most likely cause permanent damage and void its warranty.

1 SINGLE LIGHT

Follow the ID selection steps and set the GHOST to the following ID:
 - Alternating (default): ID#1 or ID#3. (includes cycle patterns and steady burn patterns)
 - Simultaneous: ID#2 or ID#4. (both lights will flash together regardless of pattern)

(Continued on opposite side)

WARNING

This product contains high intensity LED devices. To prevent eye damage, **DO NOT** stare into light beam at close range.



GHOST® SINGLE SURFACE MOUNT LIGHT W/ PERMANENT MOUNT BRACKET

EGHST4(x)B - Black

2 SINGLE LIGHTS

Follow the ID selection steps and set the GHOST to the following ID:

- IMPORTANT: Make sure both lights flash the same pattern!**
- Both assemblies simultaneous with individual lights alternating.
 - Example: Driver/Passenger sim; Dr. (left alt right) Pass. (left alt right)
 - Set both GHOST Assemblies to ID#1
 - Both assys. alternating with individual lights alternating.
 - EX: Dr./Pass. alt; Dr. (left. alt. right.) Pass. (right alt. left)
 - Set one GHOST to ID#1 and the other to ID#3
 - Both assys. alternating with individual lights simultaneous
 - EX: Dr./Pass. alt; Dr. (left sim left) Pass. (right sim right)
 - Set one GHOST to ID#2 and the other to ID#4
 - Both assys. simultaneous with individual lights simultaneous.
 - EX: Dr./Dr. sim; Dr. (left sim left) Pass. (right sim right)
 - Set both Ghost housings to ID#2

X-PATTERN - To obtain X-Patterns, follow the ID SELECTION steps and set one of the four GHOST lights to ID#1, one to ID#2, one to ID#3, and one to ID#4. Then proceed to the PATTERN SELECTION steps.

NOTE: Be sure to mount each GHOST in the correct placement based on ID#.

PATTERN SELECTION

1. Disconnect WHITE wire from any connections if applicable.
2. Turn GHOST ON.
3. Momentarily touching and removing the WHITE wire(s) to ground will advance the GHOST to the next flash pattern. Touching and removing the White wire for more than a few seconds will allow you to change the GHOST to the previous pattern. See flash pattern table. Continuing to touch and remove the WHITE wire(s) to ground will allow you to scroll through the pattern list. After pattern #33 is reached the list will start over again at pattern #1.

X-Pattern Sequence

ID#1 > ID#4 > ID#2 > ID#3

X-Pattern Light Head Placement

ID#4	ID#2
ID#3	ID#1

NOTE: The GHOST is equipped with flash pattern memory. Once you have selected a pattern the GHOST will always activate to that pattern every time the unit is turned on. Tape up and secure WHITE wire so that it will not accidentally change your selected pattern.

Ghost Sync Configuration Instructions
IMPORTANT! A MAXIMUM OF 4 SINGLE LIGHTS CAN BE SYNCED TOGETHER

1. Set ID#
 - a. Identify which pattern and sequence you want and look up ID# settings at left.
 - b. Connections
 - i. RED: +10-30Vdc
 - ii. WHT: +10-30Vdc (Note: you will need to disconnect after power is applied)
 - iii. BLK: Ground
 - c. Apply power to unit
 - d. Without disconnecting power from unit, disconnect WHT wire
 - e. Momentarily connect WHT to Ground to change ID #
 - i. Identify ID# by number of sequential flashes
 - ii. Possible ID#s: 1 - 4
 - f. Disconnect power from unit to get out of ID mode.
2. Set Pattern
 - a. Reapply power to units.
 - b. Once all Light Head ID#s are configured, make sure all lights are flashing the same pattern.
 - c. Connect corresponding colored wires of all units together: RED to RED, etc.
 - d. Change Pattern
 - i. Momentarily connect WHT wires to Ground
 - ii. Observe pattern change on all lights connected
 - e. Insulate all wires by taping with electrical tape
3. Connect Master Switch for Application
 - a. **IMPORTANT!** Ensure WHT Pattern/ Sync Wires are tied together

PATTERN RESET

1. Remove power
2. Place WHITE (sync) wire to ground
3. With sync wire grounded, re-power RED wire
4. Maintain for one second (light will dim)
5. Remove power and ground (pattern 1 set)

SLAVE MODE

The GHOST is capable of being activated through the use of a user supplied flasher by putting it in slave mode.

1. Permanently connect the GHOST WHITE and BLACK wire to a good, convenient ground.
2. Connect the GHOST RED wire, through a 5Amp fuse, to the output of a +10-30Vdc switching flasher.

Flash Patterns

Pattern Name	1 Light	Alternating 2 Lights	Simultaneous 2 Lights	X-Pattern 4 Lights	F.P.M. (Flashes / Minute)
1. Quint	x	x	x		70
2. Warp	x	x	x		350
3. Inter-Cycle Flash	x	x			
4. Double Flash	x	x	x		70
5. Quad Flash	x	x	x		80
6. PowerPulse	x	x	x		180
7. RoadRunner	x	x	x		113
8. Q-Switch	x	x			
9. RoadRunner Steady Burn	x	x			113
10. Quad Steady Burn	x	x			80
11. E-Ideal Single Flash	x	x	x		200
12. E-Ideal Double Flash	x	x	x		146
13. Quad2 Flash	x	x	x		67
14. Double2 Flash	x	x	x		95
15. X-Warp				x	
16. X-Double				x	
17. PowerRunner	x	x	x		
18. LCR Quint	x	x	x		
19. Warp?	x	x	x		
20. Ultra Warp	x	x	x		545
21. Thunder & Lightning	x	x			
22. Lite Speed	x	x	x		85
23. SuperSonic	x		x		170
24. LCR Lite Speed	x	x	x		
25. SuperSonic Ultra	x	x	x		
26. Tempo Shift	x	x	x		
27. Tempo Shift Warp	x	x	x		
28. SBE2	x	x	x		67
29. C²	x	x	x		200
30. U²	x	x	x		176
31. Ultra Glow	x	x	x		
32. Cyclone	x	x	x		
33. Chameleon	x	x	x		