

**SPC**  
**PERFORMANCE**

**Instruction**  
**ADJUSTABLE REAR ARMS**

*This part should only be installed by personnel who have the necessary skill, training and tools to do the job correctly and safely. Incorrect installation can result in personal injury, vehicle damage and / or loss of vehicle control.*

**Plan Ahead - Read All Instructions BEFORE installing part.**

*Check for loose or worn parts, proper tire pressure, and odd tire wear patterns before beginning alignment.*

1. Raise vehicle directly under rear coil springs so suspension is loaded and support with safety stands. Remove rear wheel assembly.
2. Remove OE rear upper control arm by removing both inner and outer bolts.  
**Note: It may be necessary to remove the emissions canister to gain access to the inner bolt on the right side.**
3. Adjust SPC control arm so outer bushing and adjusting nut are threaded completely into arm with no threads showing.
4. While holding outer bushing from turning, unscrew large 32mm adjusting nut until the arm length is approximately the same as the stock arm.
5. Being careful not to rotate adjuster nut or outer bushing, install arm onto vehicle using OE bolts and tighten to manufacturer's specifications. Make sure suspension is fully loaded before tightening the bushing bolts.
6. Install tire and wheel assembly and lower vehicle.
7. Adjust camber by turning large 32mm adjusting nut until desired camber is reached.

**Warning: Gap between the large adjusting nut and the outer end of the arm should not exceed 16mm (5/8"), measurement "A" - Figure 1. Exceeding the range of adjustment may cause the arm to fail and void the warranty.**

8. Tighten small pinch bolt and nut to 20 lb-ft. Tighten jam nut against adjuster nut.
9. Adjust rear toe, recheck alignment and road test vehicle.

**Always check for proper clearance between suspension components and other components of the vehicle.**

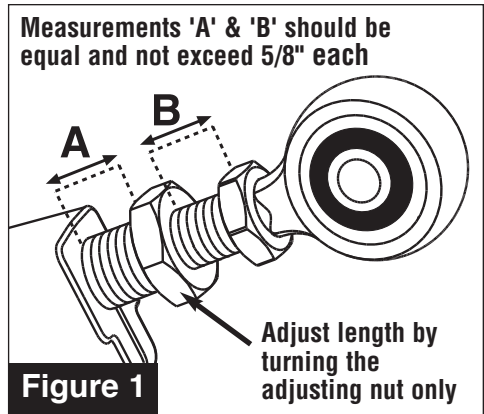

**Specialty Products Company®**

Rev. 10/16  
ECN#1555