



Calibration

IMPORTANT: This tachometer is factory calibrated to operate on 8 cylinder engines. For 4 or 6 cylinder engines, it is necessary to make the proper adjustments to adapt this tachometer to your cylinder requirement.

Locate the access hole on the back of the tachometer. Remove the black composite cover by prying it gently upwards with a small screwdriver. Move each of the two switches to the proper cylinder selection according to the diagram illustration on the right. Use a small screwdriver or an unwound paper clip to change the switch settings. Replace cover when calibration is complete.

NOTE: This tachometer has an air core meter. With power off, it is normal for the pointer to leave zero. When power is applied, the pointer will move to the correct position.

Figure A.

- 8 CYL. (4 pulse)- Both switches up.
- 6 CYL. (3 pulse)- Switch One up, Switch Two down.
- 4 CYL. (2 pulse)- Switch One down, Switch Two up.
- 4 CYL. (1 pulse)- Both switches down.

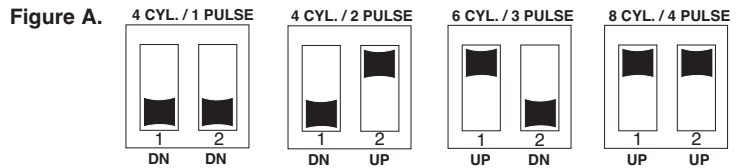

(Angle view through access hole)

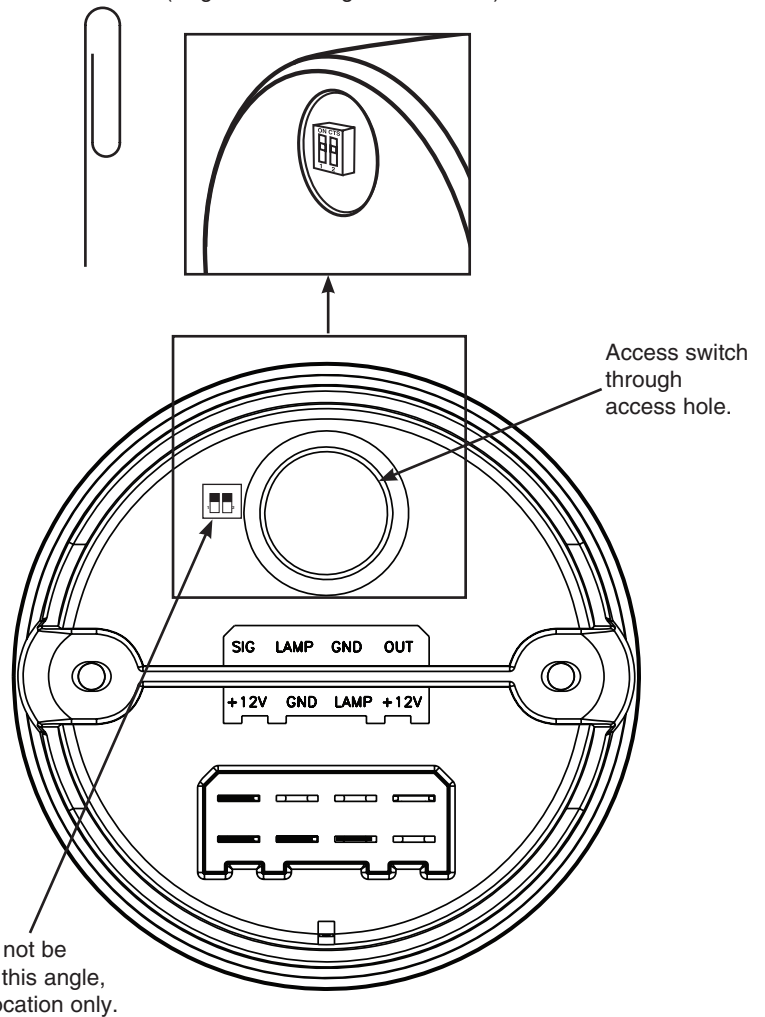

Lens Cleaning

To prevent scratching the lens when cleaning, use a mild, soapy solution to clean. Wipe lightly with a soft cloth.



Note:

This tachometer operates on most early model ignitions, factory electronic and high performance electronic racing ignitions. Some applications may require additional signal conditioning or signal adapters. Contact Stack for details.

Mounting

1. Mount the tachometer in a 86mm dia. cut out in the dashboard. (Be careful not to cut the hole too large.)
2. Cut a 10mm dia. hole in the firewall for the tachometer wires. Place included rubber grommet in the hole and route the connector wires through the grommet to the engine compartment.
3. Connect the tachometer wires as shown in the Wiring Section.
4. Secure tachometer to dashboard using the provided bracket & hardware.

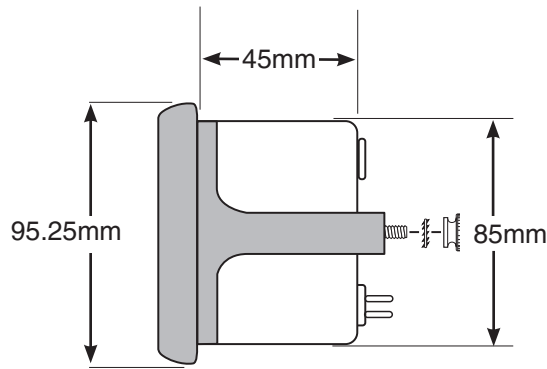

WIRING

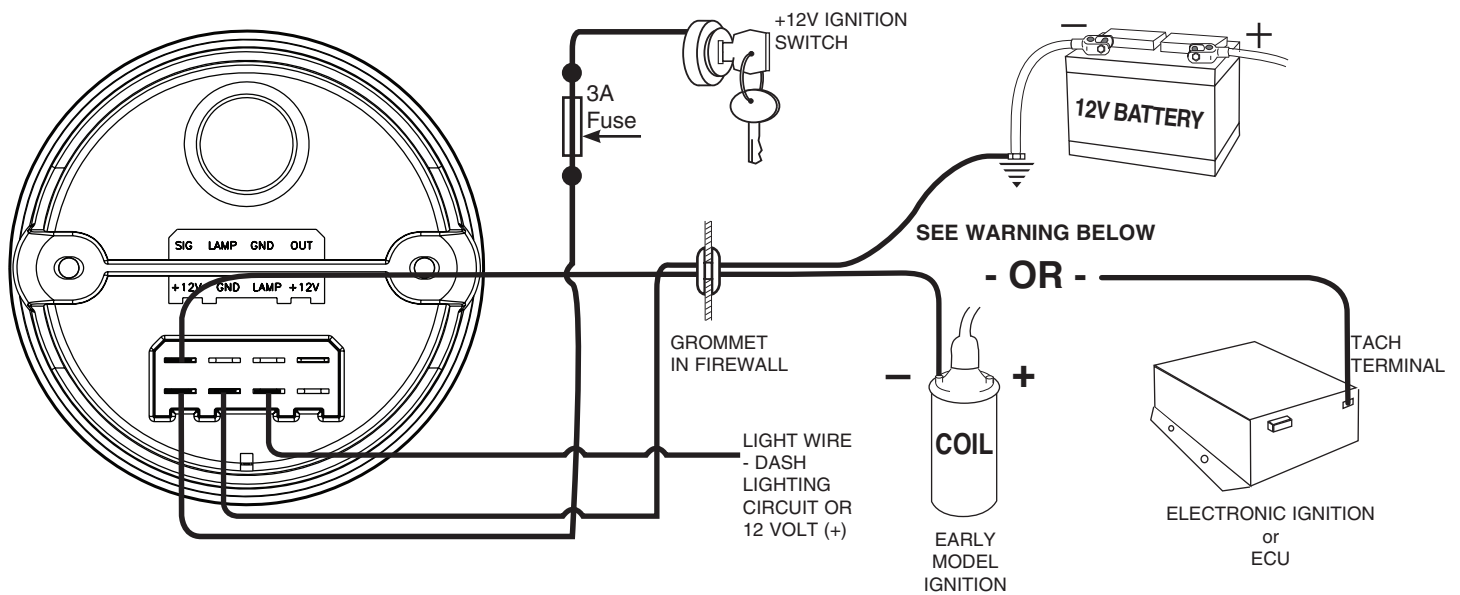

⚠ WARNING ⚠

Warranty will be void if connected to coil when using an aftermarket ignition box such as, but not limited to products from the following manufacturers: MSD, Crane, Jacobs, Mallory, Holley, Etc.. Prior to installation of your tachometer, check with the ignition box manufacturer for recommended tachometer signal location.

⚠ CAUTION! ⚠

As a safety precaution, the +12 V terminal of this product should be fused before connecting it to the 12V ignition switch. We recommend using a 3 Amp, automotive fuse or equivalent to help protect this product.