MANUAL



SABRE **LIGHTBARS**

Owner's Manual & Installation Instructions



PROUDLY MADE IN THE USA
An ISO 9001:2008 Certified Company



When mounting your lightbar, please be sure to keep any radio frequency sensitive equipment at least 20" from the bar and power cable(s). This is especially critical in lightbars utilizing strobes. Our strobe power supplies have been designed to limit RFI emissions, but certain very sensitive equipment may still be affected. Symptoms may include, but are not limited to, sporadic operation and degraded performance. Star Headlight & Lantern Co., Inc. cannot assume any responsibility for any radio frequency induced malfunction or damage to any radios, sirens, lightbars, or any other equipment mounted within 20" of a strobe lightbar. Any antennae mounted in the proximity of the lightbar may cause your radio to suffer the aforementioned results.



PLEASE NOTE: THE DIRECT MOUNT IS THE STANDARD MOUNT INCLUDED WITH THE LIGHTBAR. THE HOOK MOUNTS MUST BE USED ON ALL POLICE AND/OR OTHER EMERGENCY VEHICLES!!! THE HOOK MOUNTS ARE SOLD SEPARATELY. THEY ARE NOT INCLUDED WITH EACH LIGHTBAR. THEY MUST BE ORDERED SEPARATELY. SEE THE ACCOMPANYING HOOK MOUNT MANUAL FOR A COMPLETE LIST OF AVAILABLE MOUNTS AND KNOWN VEHICLE APPLICATIONS.



It is the sole responsibility of the owner to ensure the lightbar is mounted securely. Check your light every time you enter the vehicle to ensure that it is mounted securely. The manufacturer assumes no responsibility for the secure mounting of this light.



These lightbars contain one or more of the following light sources: Strobe Lights, Halogen Lamps, and/or High Intensity LED Lamps. **DO NOT** stare directly into any of these light sources as temporary blindness and/or permanent eye damage may occur.

Table of Contents

WARNINGS	i
QUICK-INSTALL WIRING GUIDE	1-2
MOUNTING INSTRUCTIONS	3
(For Mounting see <i>Mounting Bracket</i> Manual)	
WIRING INSTRUCTIONS	3-10
Direct Wiring Guide	3-4
Electrical Connections	5
Wire Functions	6
Strobe Power Supply Connections	7-10
PATTERN PROGRAMMING	11-14
Strobe Pack Flash Patterns	11
LED Flash Patterns	12-14
PARTS	15-17
SWITCHES	17
TROUBLESHOOTING	18-20
WARRANTY	21
SERVICE	21

QUICK-INSTALL WIRING GUIDE

Please Note: if your lightbar has an LED or incandescent traffic director in it, there will also be a separate bundled 9-conductor cable specifically for that function.

Wire Harness for Bars Without Stop/Tail/Turn Lights

P271-RAZOR

Wire Harness for Bars with Incandescent STT Lights

P271-TOWBAR Layout 1

Wire Harness for Bars With LED STT Lights

P271-TOWBAR Layout 2

Terminal Block	Terminal	Color	AWG	Function
A	1	Blue	18	Driver side Alley
	2	White w/Blue	18	Intersection Clearing Lights
	3	White w/Yellow	18	Front Corner
	4	Orange w/Yellow	18	Front Outboard
	5	Brown w/Yellow	22	Front Inboard and Ends
	6	Red	14	Power
	7	Red w/Green	22	Pattern Select
	8	Purple	22	High/Low Power (Ground for Low)
	9	Green w/Yellow	18	Lower Level Takedowns
	10	Red w/Black	18	Upper Level Takedowns or AUX
	11	White w/Brown	18	Front Pursuit
	12	Green w/Red	18	Rear Center or TD Warn
	13	Brown w/Red	22	Rear Inboard or TD Left
14	Orange w/Red	22	Rear Outboard or TD Right	
B	1	White w/Red	18	Rear Corner (rear ICL)
	2	Yellow w/Black	18	Cruise
	3	White w/Black	18	Alley w/Flash
	4	Gray	18	Passenger Alley
CONNECTED TO BASE		Black	10	Ground (Battery Negative)
		Bare	18	Shield/Drain (Battery Negative)
Terminal Block	Terminal	Color	AWG	Function
A	1	Light Blue	16	Driver Side Alley Light
	2	Orange	14	Rotators
	3			
	4	Yellow	16	Left Stop Light
	5	Green	16	Right Stop Light
	6	White/Orange	14	Work Lights
	7	Brown	18	Tail Lights/I.D. Lights
	8			OPEN
	9	Red	14	Strobe Power
	10	Red/White	14	Power for Optional Components
	11	Red/Green	22	Strobe Pattern Select
	12	Black/Green	22	Strobe Head Select 1
	13	White/Green	22	Strobe Head Select 2
	14	Gray	16	Passenger Side Alley Light
CONNECTED TO BASE		Black	10	Ground (Battery Negative)
		Bare	18	Shield/Drain (Battery Negative)
Terminal Block	Terminal	Color	AWG	Function
A	1	OPEN		OPEN
	2	OPEN		OPEN
	3	OPEN		OPEN
	4	Blue		OPEN or Driver Alley or Steady Burn Alley
	5	Orange	16	Front LEDs
	6	White w/Orange	14	Rear Work Lights
	7	Red	14	Power
	8	Red w/White	14	Rear LEDs
	9	Red w/Green	22	Pattern Select
	10	Black w/Green	22	Strobe Control 1 or OPEN
	11	White w/Green	22	Strobe Control 2 or OPEN
	12	Gray	16	OPEN or Passenger Alley
B	1	Yellow	16	Left (Driver) Turn Signal
	2	Diode		Red 6" Wire
	3	OPEN		OPEN
	4	Green	16	Right (Passenger) Turn Signal
	5	Diode		Red 6" Wire
	6	OPEN		OPEN
	7	Brown	18	Tail Lights
	8	Diode		Red 6" Wire/Power
CONNECTED TO BASE		BLACK	10	Ground (Battery Negative)
		BARE	18	Shield/Drain (Battery Negative)

Please Note: If your lightbar has an LED or incandescent traffic director in it, there will also be a separate bundled 9-conductor cable specifically for that function.

**Wire Harness for Bars With Rotators
P271-ROTOR**

Terminal	COLOR	AWG	FUNCTION
1	Blue	16	Driver Side Alley
2	White w/Brown	16	Front Flashers
3	White w/Blue	18	Intersection Clearing Lights
4	Green w/Yellow	14	Front Takedown/Worklights
5	Red w/Green	22	Pattern Select or OPEN
6	Orange	14	Rotators
7			
8	Red w/White	14	Alternate Power
9	Orange w/Black	14	Alternate Rotators
10	White	16	Rear Flashers
11	Orange w/Red	16	Alternate Rear Flasher
12	Gray	16	Passenger Side Alley
CONNECTED TO BASE	Black	10	Ground (Battery Negative)
	Bare	18	Shield/Drain (Battery Negative)

**Wire Harness for Bars with Strobe Lights
P271-STROBE**

Terminal Block	Color	AWG	Function
1	Light Blue	16	Driver Side Alley Light
2	White w/Brown	16	Pursuit
3	White w/Blue	18	Intersection Clearing
4	Green w/Yellow	14	Takedowns
5	Red	14	LED Power
6	Red w/Black	14	Driver Side or Lower Front Pattern
7	Red/White	14	Synchronization
8	Red/Green	22	Passenger Side or Lower Front Pattern
9	Black/Green	22	Rear Enable
10	White/Green	22	Front Enable
11	Orange	14	OPEN
12	White	16	Rear Flasher
13	Orange w/Red	16	High/Low Power
14	Gray	16	Passenger Side Alley Light
CONNECTED TO BASE	Black	10	Ground (Battery Negative)
	Bare	18	Shield/Drain (Battery Negative)

QUICK-INSTALL WIRING GUIDE

Mounting Instructions

Please review the separate Mounting Bracket manual that is also enclosed with your bar for mounting instructions.

Wiring Instructions

All standard lightbar models are designed for 12VDC negative ground vehicles only. Reverse polarity will cause serious damage to the lightbar and/or vehicle. Contact the automotive dealer if there are any doubts about the polarity of your vehicle.

Direct Wiring Guide

PLEASE NOTE: If you are using the existing 15-foot cable supplied with the lightbar, you may skip to the Electrical Connections section on page 4.

If the wire supplied is too short. Star recommends direct wiring to the terminal block on the inside of the lightbar, rather than making connections to the end of the wire that is supplied. This lightbar is designed so that no wire connectors are needed and only a few common tools are necessary in order to do this. Direct wiring allows the wire connections to the lightbar to be made in a clean and dry environment, avoiding any problems that may arise due to weathering on external connections. There is also an increase in voltage loss with the addition of each connection. Wiring directly inside the lightbar reduces the number of connections. However, making connections to the wires already provided is an acceptable alternative, as long as these connections are good electrical connections and are resistant from weathering effects. For direct wiring into the lightbar, follow the instructions listed below.

1. Determine the number of wires that you will need to run. This can be done by counting the number of wires coming out of your lightbar.
2. Using the Wire Usage Table on page 10, identify your wires and select appropriate wire sizes and colors.
3. Locate the end of the lightbar that has the external wires entering the base of the lightbar. The black terminal block (s), which you will be making your wire terminations to, should also be located at this same end.
4. Remove the dome lens at this end of the lightbar:

Step 1 : Loosen the four screws holding each dome on.

Step 2 : Lift the dome off of the base, exposing the interior components.

Step 3 : When all work is completed, reverse the steps to reinstall the dome, taking care that the gasket is properly aligned.

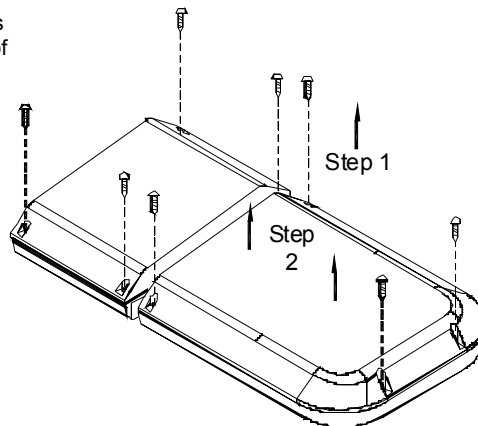

(Direct Wiring Guide CONT'D)

5. All of the wires coming from outside of the lightbar are terminated on the same side of the terminal block and the wires leading to the internal components terminate on the opposite side of the terminal block. Loosen the screws on the terminal block and remove **only those wires that exit the lightbar through the hole in the base**. There may be "dead" wires from the harness connected to the terminal block inside your lightbar, but there will be no wires connected to the terminal across from them. These are extra wires in the harness that are not used. Replacing these wires in your new harness is not necessary.

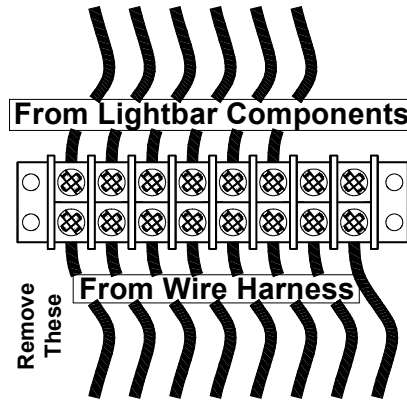

6. Run the new external wires up through the wire bushing into the base and into the terminal block(s). The function of each of the colored wires in the original wiring harness is listed in the *Wire Harness Usage Table* on page 1. There should also be a label next to the terminal block indicating which color wire should be connected to each terminal.
7. Strip each wire 1/4". Connect the external wires to the proper poles of the terminal block by inserting the stripped portion of the wire under the rising clamp screw and tightening down the screw. No wire terminals are needed for connecting wires to this terminal block.

Be sure to check that no strands of wire are loose and shorting to the adjacent terminal or to the base of the lightbar.

The correct wire size and color listed in the table on page 1 corresponds directly with the wiring of the lightbar. All switches used should be rated for at least 125% of their rated load.

8. Once your new wire harness has been connected to the lightbar, you may continue to the *Electrical Connections* section.



Electrical Connections

All standard lightbar models are designed for 12VDC negative ground vehicles only. Reverse polarity will cause serious damage to the lightbar and/or vehicle. Contact the automotive dealer if there are any doubts about the polarity of your vehicle.



RF INTERFERENCE

Please take the following steps to help eliminate any Radio Frequency Interference (RFI) with your two-way radio.

- **DO NOT** run the power wire for the lightbar along same path as any antenna wires.
 - **DO NOT** run the power wire for the lightbar along same path as any radio power wires.
 - **DO NOT** tap power for the lightbar off of the radio power wires.
 - **DO NOT** mount the lightbar within 20" of any antennae. Sometimes mounting the lightbar or antenna over by just one foot can make a large difference in the interference.
 - Ensure the black wire from the lightbar has a good connection to the **negative side of the battery.**
-
- For all standard lightbars, 15 feet of cable (usually including a drain wire and a foil shield) is supplied with the bar. All wires are color coded and sized at the correct gauge. If this length is not sufficient, it is recommended that the wire harness be completely replaced with the only connections to be made directly at the terminal block inside the lightbar. This will reduce the number of wire connections and help prevent any weathering problems on these connections. Refer to the *Direct Wiring Guide* on pages 3-4 for further instructions on this.
 - **CAUTION: All wires and switches should be rated for at least 125% of their maximum current load.** In addition, all wires connected to the positive terminal of the battery should be fused **at the battery** for 125% of their rated load. The load can be calculated by adding all lamp wattages and dividing by 13. (Load <Amps> = Total Watts / 13 volts) **Do not use** 1/4" diameter glass fuses, as they are not suitable for continuous duty above 20 amps. A table of recommended wire colors and wire sizes is provided on page 1. If you are unsure of the current draw, please contact our Customer Service Department.
 - **TESTING THE LIGHTBAR BEFORE IT IS PROPERLY FUSED & INSTALLED WILL VOID THE WARRANTY!!**
 - **The black ground wire should be connected to the negative terminal of your vehicle's battery.** This wire should be at least #10 AWG wire and be as short as possible in order to minimize the voltage loss in this wire and reduce any chance of overheating.
 - Since many of the lightbars we build have custom components, occasionally wire colors may slightly vary. If you are unsure of the function of a particular wire, you may test the function by grounding the black wire and applying +12VDC to the wire in question. Be sure to use a 20-amp fuse when testing.

Wire Functions

PLEASE NOTE: There are three different harnesses that could be installed on your lightbar. Please review the *Quick-Install Wiring Guide* on page 1 for proper connection of your wires. Your harness will contain all of the colored wires, the drain wire, and the foil shield, but most applications will not use every wire. The "dead" wires in the harness will be connected to the terminal block inside your lightbar, but there will be no wires connected to the terminal across from them. These "dead" wires can be used for additional components that may be added at some point in the future, or they may be used to separately switch components that are currently wired together.

Black: (GROUND) - The black wire is the ground wire and MUST be connected on EVERY lightbar.

Red: (Power/+12VDC) - The red wire provides the main power to the LED flashers and/or strobe packs. Connect the red wire directly to continuous +12VDC through a high-current fuse.

Please Note: When the red wire is connected to +12VDC the pack will draw a small current (50 mA). If your vehicle will be sitting for extended periods of time (i.e. more than a few days), it is recommended the red wire be routed through a switch or ignition switched relay.

Bare Wire: (Drain/GROUND) - This wire will help eliminate RFI. We recommend that it be connected to ground.

Purple: (High/Low Power) - The purple wire is optional and can be used to switch LED applications to low power. Connect the purple wire to ground to operate the bar under low power.

Red w/Green: (Pattern Select/Touch and Release to +12VDC) - The red w/green stripe wire is used to select the flash pattern of your LEDs or strobes. **It will normally be left unconnected.** (For more detailed instructions, see **Pattern Programming** on pages 8-10).

 ***Please note:*** If you have a lightbar with a strobe pack or LED flasher, the Red w/Green Stripe wire is only used when programming the flash pattern. **This wire MUST NOT be connected to continuous +12VDC!!!** Once the pattern has been selected, tape the end of this wire off. (See pages 8-10)

All Other Colors: The remaining wires are typically On/Off controls for the lights shown in the corresponding *Quick-Install Wiring Guide* on the page 1. Most applications will not use every color wire.

Connect the wires that your lightbar utilizes to +12VDC through your switches (not included). The "dead" wires (not needed) will be connected to the terminal block inside your lightbar, but there will be no wires connected to the terminal across from them. These wires do not need to be connected at the other end of the harness.

Remote Strobe Power Supply Connections For Linear Strobe Heads

If your lightbar contains linear strobe heads, follow the instructions below for proper wiring of the strobe power supply. **Please note that any additional lights in your lightbar must also be connected to +12VDC through a switch.** This section only discusses the proper wiring of the strobe power supplies. For each strobe head configuration, you will be shown two ways to wire the lightbar:

1. All strobe heads turn On and Off together
2. Separate activation of Front and Rear facing strobe heads

Lightbars with Two or Four Linear Strobe Heads

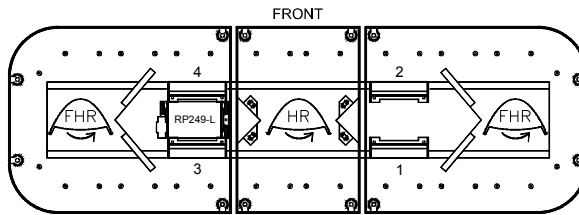

Four wires in your cable harness control the strobe power supply and the strobe heads connected to it. The functions of those wires are as follows:

- Red** - Power to the strobe power supply
- White w/Green Stripe** - On/Off control for Front Linear Strobe Heads
- Black w/Green Stripe** - On/Off control for Rear Linear Strobe Heads
- Red w/Green Stripe** - Pattern Select

Activating All Strobe Heads Together

(MOST APPLICATIONS)

To turn on all four heads connected to the power supply together, connect the Red, White w/Green Stripe, and Black w/Green Stripe together through your switch. When the switch is thrown, all of your strobes will flash. (#1 & #4 will alternate with #2 & #3)

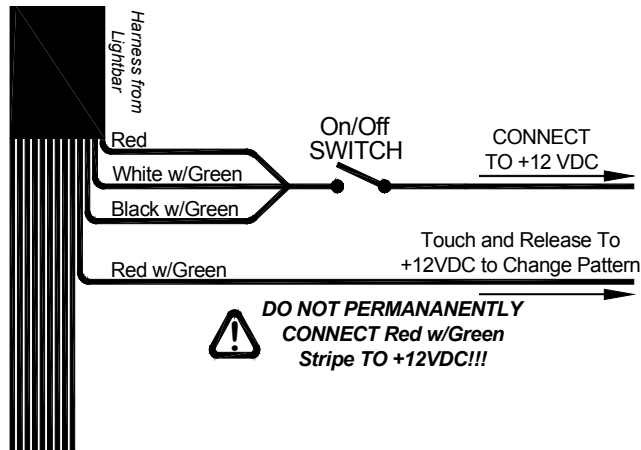

Proceed to the **Pattern Programming** section on page 11 to program the flash pattern of your strobe pack.

(Strobe Pack Connections For Lightbars With 4 Linear Heads CONT'D)

Activating the Front and Rear Strobes Separately

If you would like the ability to switch the Front Strobes On and Off separate from the Rear Strobes, connect the White w/Green Stripe wire to the switch that will activate your Front Strobes, and connect the Black w/Green Stripe wire to the switch that will activate your Rear Strobes.

The Red wire must be connected to constant +12VDC.

Please Note: When the red wire is connected to +12VDC the pack will draw a small current (50 mA). If your vehicle will be sitting for extended periods of time (i.e. more than a few days), it is recommended this wire be routed through a switch or a high-current ignition switched relay.

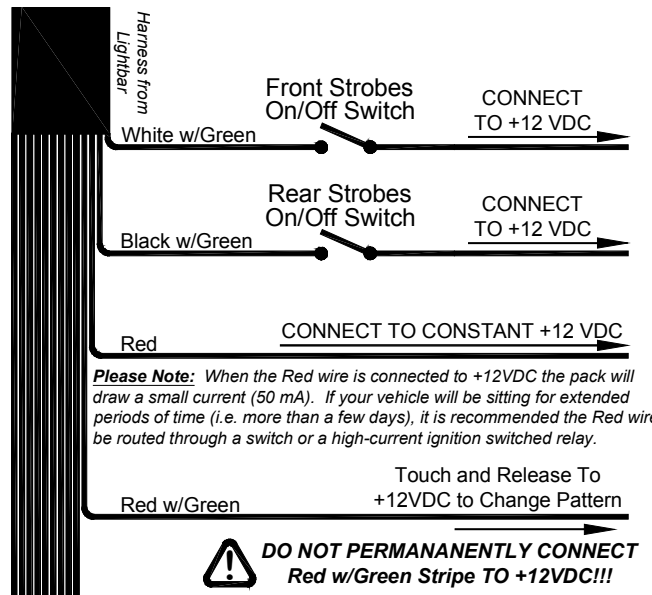

Please Note: When the Red wire is connected to +12VDC the pack will draw a small current (50 mA). If your vehicle will be sitting for extended periods of time (i.e. more than a few days), it is recommended the Red wire be routed through a switch or a high-current ignition switched relay.

Note: If you have power to both White w/Green and Black w/Green #1 & #4 will flash together alternating with #2 & #3. For two outlet packs, the two heads will alternate.

Proceed to the **Pattern Programming** section on page 11 to program the flash pattern of your strobe pack.

(Strobe Pack Connections For Lightbars With Linear Heads CONT'D)

Lightbars with Eight Linear Strobe Heads

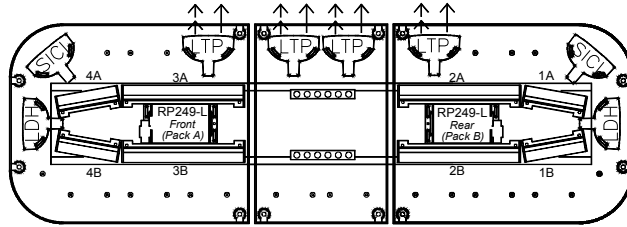

Three wires in your cable harness control the strobe power supplies and the strobe heads connected to them: The functions of those wires are as follows:

- Red** - Front Linear Strobe Heads On/Off
- Red w/Black Stripe** - Rear Linear Strobe Heads On/Off
- Red w/Green Stripe** - Pattern Select

Note: Heads #1 & #4 will flash together alternating with #2 & #3.

Activating All Strobe Heads Together

(MOST APPLICATIONS)

To turn on all eight heads connected to the power supply together, connect the Red and Red w/Black Stripe wires together through your On/Off switch. When the switch is thrown, all of your strobes will flash. (#1 & #4 will alternate with #2 & #3)

Proceed to the **Pattern Programming** section on page 11 to program the flash pattern of your strobe packs.

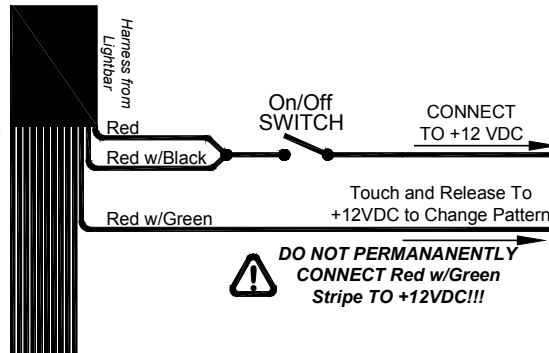

Activating Front and Rear Strobes Separately

To turn on your front strobe separately from your rear strobes, connect the Red and Red w/Black Stripe wires through two separate switches. When one switch is thrown, only the front strobes will flash. (#1 & #4 will alternate with #2 & #3). When the other switch is thrown the rear strobes will flash.

Proceed to the **Pattern Programming** section on page 11 to program the flash pattern of your strobe pack.

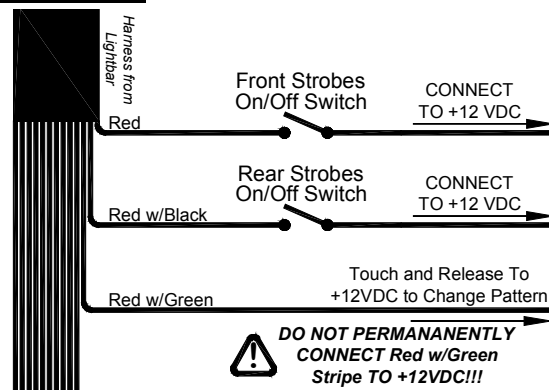

(Strobe Pack Connections For Lightbars With Linear Heads CONT'D)

Lightbars with Ten or Twelve Linear Strobe Heads

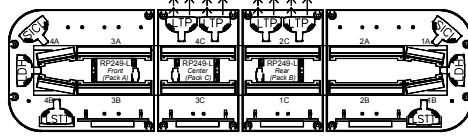

(Pictured above is one example of a bar with 12 linear strobe heads)

Four wires in your cable harness control the strobe power supplies and the strobe heads connected to them: The functions of those wires are as follows:

- Red** - Front Linear Strobe Heads On/Off
- Red w/Black Stripe** - Rear Linear Strobe Heads On/Off
- Red w/White Stripe** - Constant Power (+12 VDC) for Center Strobe Pack
- Red w/Green Stripe** - Pattern Select

Activating Front and Rear Strobes Separately

(RECOMMENDED FOR MOST APPLICATIONS)

To turn on your front strobe heads separately from your rear strobes, connect the Red w/White Stripe wire to constant +12VDC.

Please Note: When the Red w/White Stripe wire is connected to +12VDC the pack will draw a small current (50 mA). If your vehicle will be sitting for extended periods of time (i.e. more than a few days), it is recommended the Red w/White Stripe wire be routed through a switch or a high-current ignition switched relay.

Then connect the Red and Red w/Black Stripe wires through two separate switches. When one switch is thrown, only the front strobes will flash. (#1 & #4 will alternate with #2 & #3). When the other switch is thrown the rear strobes will flash.

Proceed to the **Pattern Programming** section on page 11 to program the flash pattern of your strobe pack.

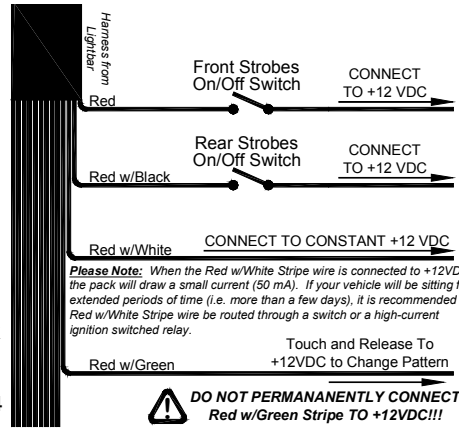

Activating All Strobe Heads Together

To turn on all of the strobe heads in your lightbar together, connect the Red, Red w/Black Stripe, and Red w/White Stripe wires together through your switch.

When the switch is thrown, all of your strobes will flash. (#1 & #4 will alternate with #2 & #3).

Please note: For this application, your switch **MUST** be able to handle 30 amps. This configuration is usually not recommended, since most switches are not capable of handling such a heavy load.

Proceed to the **Pattern Programming** section on page 11 to program the flash pattern of your strobe pack.

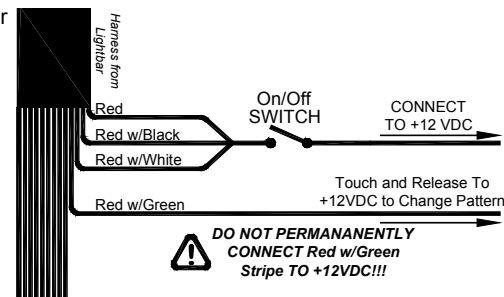

Pattern Programming

- Lightbars with LEDs or strobes can be programmed with the user's choice of flash pattern.
 - If you have both strobes and LEDs in your lightbar, **programming of the strobe pack(s) and LED flasher(s) must be done separately.**
 - If you have multiple strobe packs or multiple LED flashers, all of the strobe packs can be programmed together and all of the LED flashers can be programmed together or each strobe pack or LED flasher can also be programmed separately, if you desire different patterns for each.
1. To program the flash pattern turn **only** the strobe pack(s) or LED flasher on that you wish to program.
 2. Briefly touch the red w/green stripe wire to +12VDC and release it. Continue to briefly touch and release this wire to +12VDC until you find the pattern desired. The pattern lists for the strobe packs or various LED flashers can be found below and on the following three pages.
 3. Once you have the pattern you like, turn the pack or flasher off. The pack or flasher will remember the pattern next time it is activated.
 4. Repeat steps 1-3 for each additional strobe pack or LED flasher you wish to program.
 5. Once your programming is complete, tape the end of the red w/green stripe wire so that it does not come into contact with +12VDC.

Strobe Pack Flash Patterns

<u>Pattern</u>	<u>Warning Pattern Style</u>
1	Alternating Five-Flash (<i>default</i>)
2	Pseudo-Random
3	Alternating Singleflash
4	Alternating Doubleflash
5	Alternating Quadflash

The strobe packs are defaulted for Five-Flash mode. You can scroll through pseudo-random, singleflash, doubleflash, quadflash, and back to five-flash by touching and releasing the red w/green stripe wire to +12VDC.

Please note: If you have only the corner strobes activated (white w/yellow wire or white w/red wire), heads 1 and 4 will alternate (see the center lightbar layout diagram on page 2). If you have only the front or rear strobes activated (brown w/yellow or brown w/red) then heads 2 and 3 will alternate. If you activate the corners AND the fronts or rears at the same time, heads 1 and 4 will flash together, opposite of 2 and 3.

Automatic Power Up Head Check

Each 4-outlet power pack comes with a safety feature which checks for proper operation of each individual strobe head each time you turn on the strobe pack. This feature works by quickly flashing each head once separately and determining if any of the heads did not flash. If two heads normally flash together, and one fails and does not flash during the start up test, the strobe pack will automatically reduce the output power to that particular side so that the "other" remaining head(s) isn't over powered. The power to that side will be reduced until the strobe pack is turned off and on again and the faulty head tests good.

The 4-outlet strobe pack will check all four heads each time the pack is turned on EVEN if the head select feature is being used and only two heads are to be activated. After checking all four heads, the pack will begin flashing normally. It takes approximately 0.250 sec. to check all four heads.

Note: **If you replace the non-working head, it is necessary to cycle power to the pack before that head and the one that flashes with it will start flashing again at full power. (You should never replace a defective head with the pack activated!!)**

LED Flash Patterns

Front and Rear DLX6 and Batwing LED Patterns

(LDF375-1 Flasher)

Pattern	Warning Pattern Style
1	Pursuit Mode (1 flash/3 sec default)
2	Alternating Slow Single (1-5 vs 6-10) (Title 13 Approved)
3	Alternate Pursuit Mode
4	Alternating Quad Flash (1-5 vs 6-10)
5	Alternating Triple (1,2,6,7,8 vs 3,4,5,9,10)
6	Alternating Quint (1,2,6,7,8 vs 3,4,5,9,10)
7	Simultaneous Slow Single (All Modules) (Title 13 Approved)
8	Simultaneous Fast Single (All Modules)
9	Simultaneous Triple Flash (All Modules)
10	Simultaneous Quad Flash (All Modules)
11	Simultaneous Quint Flash (All Modules)
12	Simultaneous Fast Triple Flash (All Modules)
13	Simultaneous Fast Quint Flash (All Modules)
14	In/Out Single (1,2,9,10 vs 3-8)
15	In/Out Triple (1,2,9,10 vs 3-8)
16	In/Out Quint (1,2,9,10 vs 3-8)
17	In/Out Single (1,2,3,8,9,10 vs 4-7)
18	In/Out Triple (1,2,3,8,9,10 vs 4-7) (2 flashes/6 sec default)
19	In/Out Quint (1,2,3,8,9,10 vs 4-7)
20	1-5 Steady; 6-10 Single Flash (Title 13 Approved)
21	1-5 Steady; 6-10 Slow Single Flash (Title 13 Approved)
22	6-10 Steady; 1-5 Single Flash (Title 13 Approved)
23	6-10 Steady; 1-5 Slow Single Flash (Title 13 Approved)
24	Sequential Back And Forth (3 flashes/9 sec default)
25	Sequential In/Out
26	Burst All w/ Alternating Burst
27	Alternating Burst w/ Simultaneous Double Then Quint
28	Simultaneous Burst w/ Alternating Double Then Quint
29	Hyper-Random
30	Pre-Pop Triple Flash
31	Alternating Pre-Pop Triple Flash
32	Demo (Cycle Through Patterns 1-4,6-9,13-20,25-29)

Please Note: At any time during the programming sequence, you can reset the flash pattern back to any of the default patterns (Pattern 1, 18, or 24) by holding the red w/green Pattern Select wire to +12VDC until the heads flash the specified number of times, then releasing it.

Each LED flasher has 20 output terminals (10 pairs). The two terminals in each pair are electrically connected and will flash at the same time. The numbers in parenthesis in the list above indicate which output pairs flash together vs. the pairs they flash opposite of.

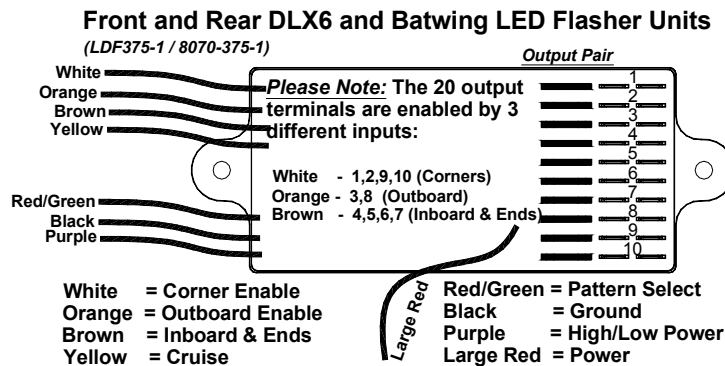

(LED Pattern Programming CONTD)

Takedown or Alley Light DLX6 and Batwing LED Patterns
(LDF375-2 Flasher)

Pattern	Warning Pattern Style
1	Pursuit Mode (1 flash/3 sec default)
2	Alternating Slow Single (1,3 vs 2,4) (Title 13 Approved)
3	Alternate Pursuit Mode
4	Alternating Quad Flash (1,3 vs 2,4)
5	Alternating Triple (1,3 vs 2,4)
6	Alternating Quint (1,3 vs 2,4)
7	Simultaneous Slow Single (All Modules) (Title 13 Approved)
8	Simultaneous Fast Single (All Modules)
9	Simultaneous Triple Flash (All Modules)
10	Simultaneous Quad Flash (All Modules)
11	Simultaneous Quint Flash (All Modules)
12	Simultaneous Fast Triple Flash (All Modules)
13	Simultaneous Fast Quint Flash (All Modules)
14	In/Out Single (1,3 vs 2,4)
15	In/Out Triple (1,3 vs 2,4)
16	In/Out Quint (1,3 vs 2,4)
17	Simultaneous Double Flash, Post-Pop (2 flashes/6 sec default)
18	Simultaneous Triple Flash, Post-Pop
19	Simultaneous Quint Flash, Post-Pop
20	Alternating Double Flash, Post-Pop (1,3 vs 2,4)
21	Alternating Triple Flash, Post-Pop (1,3 vs 2,4)
22	Alternating Quint Flash, Post-Pop (1,3 vs 2,4)
23	Alternating Pre-Pop Quint Flash (1,3 vs 2,4)
24	Sequential Back And Forth (3 flashes/9 sec default)
25	Sequential In/Out
26	Burst All w/ Alternating Burst
27	Alternating Burst w/ Simultaneous Double Then Quint
28	Simultaneous Burst w/ Alternating Double Then Quint
29	Hyper-Random
30	Demo (Cycle Through Patterns 1-4,6-9,13-20,25-29)

The numbers in parenthesis in the list above indicate which output pairs flash together vs. the pairs they flash opposite from.

Please Note: Please Note: At any time during the programming sequence, you can reset the flash pattern back to any of the default patterns (Pattern 1, 18, or 24) by holding the red w/green Pattern Select wire to +12VDC until the heads flash the specified number of times, then release it.

Takedown (Pursuit) and Alley LED Flasher Units

(LDF375-2 / 8070-375-2)

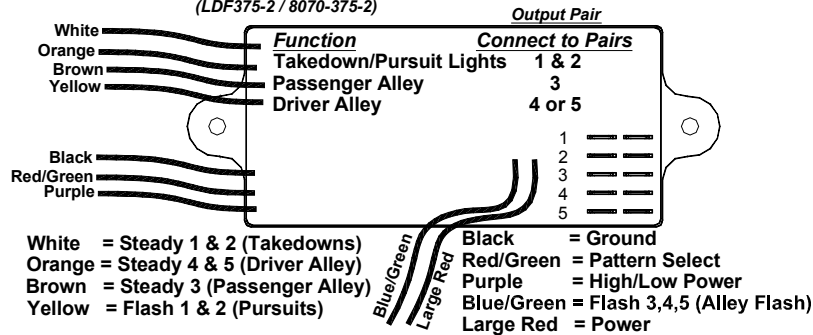

(LED Pattern Programming CONTD)

Patterns for All LEDs Excluding DLX6 and Batwing
(LDF398 Flasher)

Pattern	Warning Pattern Style
1	Pursuit Mode (Default)
2	Alternating Slow Single (1-5 vs 6-10) (Title 13 Approved)
3	Alternate Pursuit Mode
4	Alternating Quad Flash (1-5 vs 6-10)
5	Alternating Triple (1,2,6,7,8 vs 3,4,5,9,10)
6	Alternating Quint (1,2,6,7,8 vs 3,4,5,9,10)
7	Simultaneous Slow Single (All Modules) (Title 13 Approved)
8	Simultaneous Fast Single (All Modules)
9	Simultaneous Triple Flash (All Modules)
10	Simultaneous Quad Flash (All Modules)
11	Simultaneous Quint Flash (All Modules)
12	Simultaneous Fast Triple Flash (All Modules)
13	Simultaneous Fast Quint Flash (All Modules)
14	In/Out Single (1,2,9,10 vs 3-8)
15	In/Out Triple (1,2,9,10 vs 3-8)
16	In/Out Quint (1,2,9,10 vs 3-8)
17	In/Out Single (1,2,3,8,9,10 vs 4-7)
18	In/Out Triple (1,2,3,8,9,10 vs 4-7)
19	In/Out Quint (1,2,3,8,9,10 vs 4-7)
20	1-5 Steady; 6-10 Single Flash (Title 13 Approved)
21	1-5 Steady; 6-10 Slow Single Flash (Title 13 Approved)
22	6-10 Steady; 1-5 Single Flash (Title 13 Approved)
23	6-10 Steady; 1-5 Slow Single Flash (Title 13 Approved)
24	Sequential Back And Forth
25	Sequential In/Out
26	Burst All w/ Alternating Burst
27	Alternating Burst w/ Simultaneous Double Then Quint
28	Simultaneous Burst w/ Alternating Double Then Quint
29	Hyper-Random
30	Demo (Cycle Through Patterns 1-4,6-9,13-20,25-29)





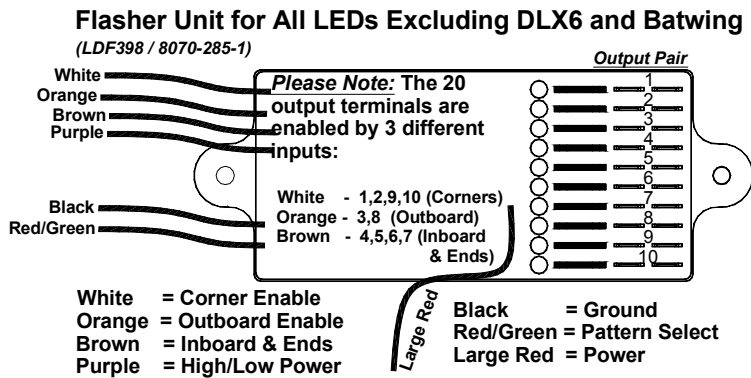



Each LED flasher has 20 output terminals (10 pairs). The two terminals in each pair are electrically connected and will flash at the same time. The numbers in the list above, in the parenthesis, indicate which output pairs flash together vs. the pairs they flash opposite of.

Please Note: At any time during the programming sequence, you can reset the flash pattern back to the default mode (Pattern 1 – Pursuit) by holding the red w/green Pattern Select wire to +12VDC for 5 seconds, then releasing it.

















SABRE Parts









Bulbs and Tubes

-  LST129-4
4.5" LINEAR STROBE TUBE
-  LST129-7
7" LINEAR STROBE TUBE
-  ST3901-7
360° STROBE HEAD
-  2073-H50S (4 amps)
50-WATT SHORT HALOGEN BULB
(FOR ROTATORS AND TAKEDOWNS)
-  2073-1157 (2.1 amps)
STOP-TURN-TAIL BULB
-  2073-H27 (2.1 amps)
27-WATT HALOGEN BULB
(LOWER LEVEL)
-  2073-94 (1 amp)
INCANDESCENT DIRECTIONAL
ARROW BULB
-  ST3901-12
STROBE TUBE FOR STROBE
INTERSECTION CLEARING LIGHT





Power Supplies/Flashers

-  RP249-L (9 amps)
4-HEAD REMOTE STROBE PAK
-  RP249-A (7 amps)
2-HEAD REMOTE STROBE PAK
-  520-181-SBQ2 (2 amps)
2-HEAD REMOTE STROBE PAK and
REPLACEMENT 520-29 V-Mirror
-  520-181-SBQ2 (2 amps)
2-HEAD REMOTE STROBE PAK and
REPLACEMENT 520-29-2 LARGE V-Mirror
-  TD77-2
TRAFFIC DIRECTOR CONTROL BOX
-  LDC-TD
LED CONVERTER CIRCUIT FOR TD77-2
WHEN USED w/M-Tech HEADS
-  FM3661-S
1.9 FPS HALOGEN FLASHER
-  FM3662-S
2.9 FPS HALOGEN FLASHER
-  LDF398
8-OUTPUT LED FLASHER FOR M-TECH HEADS
(20 OUTPUT TERMINALS)
-  LDF375-1
8-OUTPUT LED FLASHER w/CRUISE
FOR VERSASTAR HEADS
(20 OUTPUT TERMINALS)
-  LDF375-2
8-OUTPUT LED FLASHER FOR
ALLEYS & TDP VERSASTAR HEADS
(20 OUTPUT TERMINALS)
-  LDF288-ICL
8-OUTPUT LED FLASHER FOR
ALLEYS & TDP VERSASTAR HEADS
(20 OUTPUT TERMINALS)
-  LDF369
2-OUTPUT LED FLASHER FOR ALL LED HEADS
EXCEPT M-TECH & VERSASTAR (8 OUTPUT TERMINALS)
-  LDF389
STT Controller for Lower Level Linear
LED Heads (820-14D1-R)







Domes, Filters, and Lenses

-  520-21-1*
UPPER END DOME
(* = A, B, C, G, or R)
-  520-22-1*
UPPER CENTER DOME
(* = A, B, C, G, or R)
-  820-21L-1*
LOWER INTERCEPTOR/SABRE
END DOME (* = A, B, C, G, or R)
-  520-22L-1*
LOWER INTERCEPTOR/SABRE
CENTER DOME (* = A, B, C, G, or R)
-  520-100-1*
COLOR FILTER FOR LOW
PROFILE ROTATORS
(* = A, B, G, R)
-  LSF4.5-1*
COLOR FILTER FOR 4.5" SH3964
STROBE HEAD (* = A, B, G, R)
-  LSF7-1*
COLOR FILTER FOR 7" SH3967
STROBE HEAD (* = A, B, G, R)
-  820-100LL-1*
COLOR FILTER FOR LOWER
LEVEL LIGHTS (* = A, B, G, R)
-  333-5-1*
DOME FOR 360° STROBE HEAD
(* = A, B, C, G, or R)

Mirrors



















-  520-29-1
SMALL V-MIRROR FOR
SABRE AND RAZOR LIGHTBARS
-  520-29
MEDIUM V-MIRROR FOR
SABRE AND RAZOR LIGHTBARS
-  520-292
MEDIUM DOUBLE V-MIRROR
FOR SABRE AND RAZOR LIGHTBARS
-  520-29-2
LARGE V-MIRROR
FOR SABRE AND RAZOR LIGHTBARS
-  520-2*
Z-MIRROR FOR SABRE
(* = L or R)

Miscellaneous



















-  820-39-PB
DIRECT MOUNT KIT
-  HOOK MOUNTS
THESE ARE PICTURED IN THE HOOK MOUNT MANUAL
AND WORK IN CONJUNCTION WITH THE 820-39P*
* = COLOR (White, Black, Clear, or Gray)
-  30047-61
DOME GASKETING (1 FOOT)
-  30053-33
TOP DOME SCREWS
-  920-37 (0.33 amps)
SINGLE ID/MARKER LIGHT FOR 820-38-1
-  820-36 (1 amp)
TRIPLE I.D./MARKER LIGHT BRACKET ONLY
-  820-38-1 (1 amp)
TRIPLE I.D./MARKER LIGHT BRACKET
WITH THREE 920-27 ID LIGHTS

(Parts CONT'D)







Upper Level Lighting

-  520-99 OR 520-99F (4 amps)
95FPM OR 150FPM HALOGEN
ROTATOR
-  ST3901-7
360° REMOTE STROBE HEAD
-  RSK520-SBQ (2 amps)
2-HEAD 360° STROBE KIT W/181SBQK POWER
SUPPLY/MIRROR ASSEMBLY AND TWO
ST3901-7 HEADS
-  SH3954 (SH3954-1 when angled)
4" LINEAR STROBE HEAD FOR
SABRE AND RAZOR LIGHTBARS
-  RSK249A-L4K (7 amps)
4.5" 2-HEAD LINEAR STROBE KIT
W/WRP249A-L POWER SUPPLY
-  RSK249-L4K (9 amps)
4.5" 4-HEAD LINEAR STROBE KIT
W/WRP249-L POWER SUPPLY
-  SH3957
7" LINEAR STROBE HEAD FOR
SABRE AND RAZOR LIGHTBARS
-  RSK249A-L7K (7 amps)
7" 2-HEAD LINEAR STROBE KIT
W/WRP249A-L POWER SUPPLY
-  RSK249-L7K (9 amps)
7" 4-HEAD LINEAR STROBE KIT
W/WRP249-L POWER SUPPLY
-  LSF-EC-
LINEAR STROBE ENDCAP
-  520-51 (2.1 amps)
LOW PROFILE UPPER LEVEL
TAKEDOWN / WORKLIGHT
-  520-51F (2.1 amps)
LOW PROFILE UPPER LEVEL
FLASHING LIGHT
-  520-51FK* (2.1 amps)
2-LIGHT LOW PROFILE HALOGEN
FLASHER KIT W/FM3662 FLASHER
FRONT or REAR (*=F or R)
-  520-51HP (2.1 amps max)
LOW PROFILE UPPER LEVEL
TAKEDOWN/PURSUIT LIGHT
-  S520-DLX6-3*
DLX6 END OR CORNER LED
-  S520-DLX6-4*
DLX6 OUTER LED
-  S520-DLX6-1*
DLX6 INNER LED
-  520-DLXLL6-1*
DLX6 INNER LED WITH BRACKET

M-TECH HEADS (Standard or Value Versions)

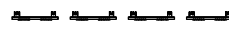
-  520-D1 or 520-D1V (0.8 amps max)
M-Tech LED Lighthouse
-  520-D1AL or 520-D1ALV (0.8 amps max)
M-Tech LED Lighthouse
w/Left Angle Reflector
-  520-D1AR or 520-D1ARV (0.8 amps max)
M-Tech LED Lighthouse
w/Right Angle Reflector
-  520-D1LEC or 520-D1LECV (0.8 amps max)
M-Tech LED Lighthouse w/Left Endcap
-  520-D1REC or 520-D1RECV (0.8 amps max)
M-Tech LED Lighthouse w/Right Endcap
-  520-D1EC or 520-D1ECV (0.8 amps max)
M-Tech LED Lighthouse w/Endcaps
-  520-D3 or 520-D3V (1.6 amps max)
M-Tech LED 3-Lighthouse End Assembly
-  520-D2 or 520-D2V (1.6 amps max)
M-Tech LED 2-Lighthouse End Assembly
-  220-ECL
M-TECH LEFT ENDCAP W/LENS
-  220-ECR
M-Tech Right Endcap w/Lens
-  LDH3903-* (0.4 amps max)
LOW PROFILE 3-ARRAY
LINEAR LED HEAD
(*=COLOR)
-  LDH3903K2-* (0.8 amps max)
2-HEAD LINEAR 3-LED KIT W/
LDF369 FLASHER
(*=A,B,C,R,BR)
-  LDH3903K4-* (1.6 amps max)
4-HEAD LINEAR 3-LED KIT W/
LDF369 FLASHER
(*=A,B,C,R,BR)
-  LDH3906-1-* (0.8 amps max)
LOW PROFILE 6-ARRAY
LINEAR LED HEAD
(*=COLOR)
-  LDH6K2-1** (1.6 amps max)
2-HEAD LINEAR 6-LED KIT W/
LDF369 FLASHER (*=A,B,C,R,BR)
-  LDH6K4-* (3.2 amps max)
4-HEAD LINEAR 6-LED KIT W/
LDF369 FLASHER (*=A,B,C,R,BR)
-  S520-308-4*
BATWING LED
-  S520-308-6*
BATWING T.D. LED

























Traffic Directors

-  820-14TDAK (8 amps max)
LOWER LEVEL INCADESCENT ARROWSTICK FOR
INTERCEPTOR w/TD77-2 CONTROLLER & CABLE
-  820-14TDK46 (2 amps max)
LOWER LEVEL LED ARROWSTICK FOR 46"
BARS w/TD77-2 CONTROLLER & CABLE
-  820-14TDK56 (2 amps max)
LOWER LEVEL LED ARROWSTICK FOR 56"
BARS w/TD77-2 CONTROLLER & CABLE
-  820-14TDK6* (1.5 amps max)
LOWER LEVEL 6 ARRAY LED ARROWSTICK
w/TD77-2 CONTROLLER & CABLE (*=A,R)
-  S520-DLX6TDK6A
DLX6 TRAFFIC DIRECTOR KIT
-  S520-BWTDK6A
BATWING TRAFFIC DIRECTOR KIT

Please note that these items are not drawn to scale. Many have been enlarged to show more detail

(Parts CONT'D)

Lower Level Lighting

- | | | | |
|---|--|--|---|
|  | 820-14D1-1* (0.65 amps)
1 LOWER LEVEL LED ARRAY
For Flashers or STT (*=A,B,R,BR) |  | 820-14 or 820-14LDH (2.1 amps)
LOWER LEVEL DIRECTIONAL HALOGEN LIGHT |
|  | 820-1LDF* (0.65 amps)
1 LOWER LEVEL LED ARRAY (820-14D1*)
w/LDF369 FLASHER (*=A,B,R,BR) |  | 820-14LAL (2.1 amps)
LOWER LEVEL ALLEY LIGHT |
|  | 820-2LDFK** (1.3 amps max)
2 LOWER LEVEL LED ARRAYS
w/LDF369 FLASHER (*=A,B,R,BR) |  | 820-14ALK (4.2 amps max)
LOWER LEVEL ALLEY LIGHT KIT |
|  | 820-14LDSTTK (1.3 amps max)
2 LOWER LEVEL RED LED ARRAYS
w/LDF369 STT FLASHER |  | 820-14DHK* (*=F or R) (4.2 amps max)
LOWER LEVEL DIRECTIONAL HALOGEN
2-LIGHT KIT (TAKEDOWNS/WORKLIGHTS) |
|  | 820-4LDFK-**** (2.6 amps max)
4 LOWER LEVEL LED ARRAYS
w/LDF369 FLASHER (*=A,B,R,BR) |  | 820-14DHK4* (*=F or R) (8.4 amps max)
LOWER LEVEL DIRECTIONAL HALOGEN
4-LIGHT KIT (TAKEDOWNS/WORKLIGHTS) |
|  | 820-14D2-1* (0.5 amps max)
LOWER LEVEL DOUBLE LED ARRAY (*=A,R) |  | 820-14STT (2.1 amps)
LOWER LEVEL STOP/TAIL/TURN LIGHT |
|  | 820-14D3-1* (0.75 amps max)
LOWER LEVEL TRIPLE LED ARRAY (*=A or R) |  | 820-14LDF (1.05 amps)
LOWER LEVEL FLASHING LIGHT |
|  | S520-DLX6LL-1*
DLX6 LOWER LEVEL LED |  | 520-14DHFK* (*=F or R) (2.1 amps max)
LOWER LEVEL 2-LIGHT FLASHER KIT w/FM3662-S
FLASHER FRONT or REAR (*=F OR R) |
|  | S520-308LL-4*
BATWING LED |  | 520-14DHPK4* (*=F or R) (4.2 amps max)
LOWER LEVEL 4-LIGHT FLASHER KIT w/FM3662-S
FLASHER FRONT or REAR (*=F OR R) |
|  | S520-DLX6ICLK
DLX6 LED INTERSECTION CLEARING LIGHT KIT |  | 820-14LTP (2.1 amps max)
LOWER LEVEL TAKEDOWN/PURSUIT LIGHT |
|  | 520-DLX6ICLK
LOWER LEVEL LED INTERSECTION CLEARING LIGHT
KIT w/LDF288-ICL FLASHER AND BRACKETS |  | 520-14DHPK* (*=F or R) (4.2 amps max)
LOWER LEVEL 2-LIGHT TAKEDOWN/PURSUIT KIT
w/FM3662-S FLASHER FRONT or REAR (*=F OR R) |
|  | 820-14ICL (2.1 amps max)
LOWER LEVEL INTERSECTION CLEARING LIGHT |  | 520-14DHPK4* (*=F or R) (8.4 amps max)
LOWER LEVEL 4-LIGHT TAKEDOWN/PURSUIT KIT
w/FM3662-S FLASHER FRONT or REAR (*=F OR R) |
|  | 820-14ICLK (2.1 amps max)
LOWER LEVEL INTERSECTION CLEARING
LIGHT KIT w/FM3662 FLASHER | | |

Please note that these items are not drawn to scale. Many have been enlarged to show more detail

Switches and Switchboxes

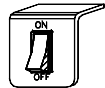

SP3860-1

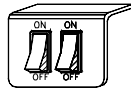

SP3860-2

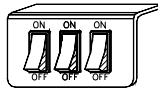

SP3860-3

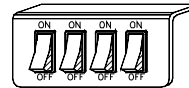

SP3860-4

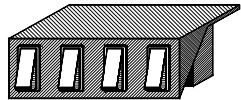

SP1515

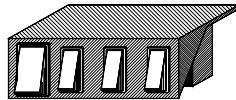

SP3015

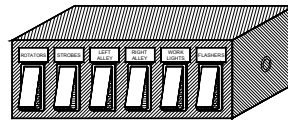

SB4020



SB1515



SB3015

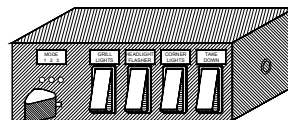

SB4040

Troubleshooting



CAUTION: High voltages exist in electronic strobe lights. Before attempting service on any strobe light, be sure to disconnect the power for at least five minutes to allow the capacitor to discharge. Failure to heed this warning may result in severe electrical shock and/or injury.

Please Note: Most strobe and rotating beacon failures can be traced to wiring and battery problems. Before attempting any service on the circuit itself, please be sure to check all connections and wiring to ensure the correct voltage and/or polarity is reaching your light or remote head.

*If a light on your bar fails to work, please refer to this section to help solve your problem. If you still cannot resolve your problem, please contact our **Customer Service Department** at 585-226-9787.*

The chart below contains some basic guidelines for troubleshooting any problems you may experience with your bar. The section following the chart will explain in further detail how to perform some of the troubleshooting tasks.

<u>Symptom:</u>	<u>Possible Solutions</u>
One single LED light is Out	LED Head needs to be replaced
One LED head does not flash	Check wiring between LED head and flasher unit Check LED head Check that +12VDC is applied to control line for that head
Multiple LED heads not flashing	Check power to terminal block Check that the bar is properly grounded Check power from terminal block to LED flasher unit Check that the LED flasher unit is grounded properly Check that +12VDC is applied to control line for those heads Check that the red w/green stripe pattern select wire is not connected to +12VDC
One flashing light out	Check bulb Check power wire from flasher unit to bulb Check that the bulb is grounded
Multiple flashing lights out	Check power to terminal block Check that the bar is properly grounded Check power from terminal block to flasher unit Check that the flasher unit is grounded properly
One remote strobe head out	Check the strobe head Check the cable from the remote pack to the strobe head
Multiple strobe heads out	Check power to terminal block Check power to strobe pack Power Outlet (PWR) Check power to strobe pack Control Outlets (CTRL) Check that the pack is properly grounded Check that the red w/green stripe pattern select wire is not connected to +12VDC

Determining if the bar is properly grounded:

1. While the bar is turned on, using a test meter, measure the voltage from the base of the bar itself to the negative post of the battery or a good chassis ground if the battery can't be easily reached. You may need to scrape away a bit of anodizing or paint in order to ensure a good connection with the probe of your test meter.
2. If the difference shown is greater than .25 volts, then your ground is not sufficient.
3. If the ground is insufficient, locate the ground wire connection in your lightbar by removing the dome over the section where the wires enter the bar. Please follow the appropriate dome removal instructions listed earlier in this manual when removing this dome. The ground wire is the large (10AWG) black wire attached to the inside of the lightbar base with a ring terminal. Check the integrity of the connection of the ground wire to both the lightbar base and at the other end to a good chassis ground.
4. While inspecting the ground wire connections you should also check that the wire itself is not damaged. Carefully inspect the wire along its entire length, paying special attention to those areas where the wire passes through any holes that may have sharp edges, which can damage the wire, and the areas where the wire makes any sharp bends.

**Checking the power to the terminal block
(Determining if the proper voltage is reaching your bar):**

1. Locate the terminal block in your lightbar by removing the dome over the section where the wires enter the bar. Please follow the appropriate dome removal instructions listed earlier in this manual when removing this dome. After entering the bar, the wires will be connected to the terminal block with a number of small Phillips head screws.
2. With the bar turned on, use a test meter to test the voltage at the terminal block. A nominal 12.5 volts should be present. Low voltage can cause erratic flashing in strobe heads or even complete failure of the heads. A minimum of 10.5 volts should be present for the pack to operate properly. Low voltage in strobe lights, flashing lights, or LEDs can result in lowered intensity or even complete failure.
3. Be sure to test each wire that comes into the terminal block for proper voltage.
4. Carefully inspect each wire in the terminal block. Check that the ends of the wires have not frayed and shorted against one another or against the base. This may cause lights to operate inadvertently or may result in the failure of lights.

Checking one non-working strobe or LED head:

If a problem exists in only one head, a strobe tube or LED head may have burned out, or there may be an open electrical connection in the wiring harness or strobe head.

1. Check connections at and between the strobe pack and the faulty strobe head or between the flasher unit and LED head, including all wiring.
2. Disconnect both the faulty head and a working head.
3. Check the faulty head by connecting it into the side you just unplugged the working head from. If the faulty head still does not work, then the head is bad and will need to be replaced.
4. If the head that was not flashing works when connected to the other side, the problem probably lies in the power pack or flasher unit. Verify this by plugging the other head (the original working head you just unplugged) into the side that previously had the non-working head.

Checking multiple non-working strobe or LED heads:

If two or more of the heads connected to one of the packs are not flashing, follow these steps to determine the problem:

1. Check the power to the terminal block as explained on the previous page.
2. Check that the bar is grounded properly as explained on the previous page.
3. Check all fuses, including those at the battery, at the switch panel, in the dash, and on the pack (if applicable). Remove these fuses, and check them to confirm they have not blown. Replace any blown fuses with only fuses of identical values. Replacing the fuse with the wrong rating may damage your pack and/or vehicle, and will void your warranty.
4. Check that the proper voltage is reaching the pack or flasher unit with the vehicle turned off and while the bar is running. For strobe packs, measure the voltage across the red wire (pin 1) and the black or blue wire (pin 2) of the **PWR** connector on the power pack. Push the probes of the test meter down into the connector at the wire entry points to contact the terminals for the measurement. Note this reading. A nominal 12.5 volts should be present. Low voltage to the pack can cause erratic flashing in the heads or even complete failure of the heads. A minimum of 10.5 volts should be present for the pack to operate properly. If you do not have proper voltage present skip to step 8. If your pack is receiving sufficient voltage then continue to step 5.
5. Check that the proper voltage is reaching the Black wire and White wire of the **CTRL** plug on your strobe pack with the vehicle turned off and while the bar is running. Measure the voltage across the Black wire (pin 2) and a good chassis ground. Push the probes of the test meter down into the connector at the wire entry points to contact the terminals for the measurement. Note this reading. Also check the voltage on the White wire. A nominal 12.5 volts should be present. A minimum of 10.5 volts should be present for the pack to operate properly. If you do not have proper voltage present, skip to step 8. If your pack is receiving sufficient voltage then continue to step 6.
6. Check that there is NO VOLTAGE on the Red w/Green Stripe wire (Pattern Select wire) of the **CTRL** plug on your strobe pack. Measure the voltage across the Red w/Green stripe wire (pin 1) and a good chassis ground. Push the probes of the test meter down into the connector at the wire entry points to contact the terminals for the measurement. If there is voltage being applied to this wire, it will prevent the strobe pack from flashing.
7. If the leads in one of the heads have shorted out, the output voltage of the other heads may be held down as well. To test for this, unplug all of the heads and plug them in individually, one at a time. If your problem is a result of a shorted head, then the other heads should function properly if the faulty head is no longer connected. Note: A burned out strobe tube does not cause a short and will not affect the operation of the remaining heads. If the problem is not with a shorted head and if proper voltage is reaching the pack, the problem is most likely internal to the pack. Call Star to obtain an R.G.A. number to return the pack for service.
8. If sufficient voltage is not reaching the pack perform the following tests: With the vehicle turned off and while the pack is running, measure the battery voltage *at the battery*. A nominal 12.5 volts should exist. Note this voltage. If this voltage is below 10.0 volts the pack will not function properly and the problem is with the battery. This reading should not be more than 1-1.25 volts higher than the reading in the 4th step. If there is an excessive difference then continue on to the next step.
9. With the vehicle not running and the lightbar on, measure the voltage in the red wire by taking a reading from the positive side of the battery to pin 1 of your switch. If this reading exceeds 0.25 volts then there is a poor connection between the switch and the battery in the red wire and it should be checked.
10. If you still have not located the problem, troubleshoot the connections between the good chassis ground and pin 2 (black wire) of the **PWR** connector on the power pack, while the lightbar is running. If this reading exceeds 0.25 volts then there is a poor connection between the switch and the ground in the black wire and it should be checked.
11. This same procedure can be used to check the wires between the terminal block and the pack. Place one probe on the terminal at the terminal block and the other probe into the terminal with the corresponding wire color in the connector on the pack. Once again if any of the readings exceed 0.25 volts then you should check those wires and their connections.