

STEMCO GAFF Product Tip # 06

13601 Bolster Spring

STEMCO GAFF is releasing the enhanced version of the 13601 Bolster Spring, in addition the creation of 2 new bolster kits for these suspension repairs 13721 and 13722.

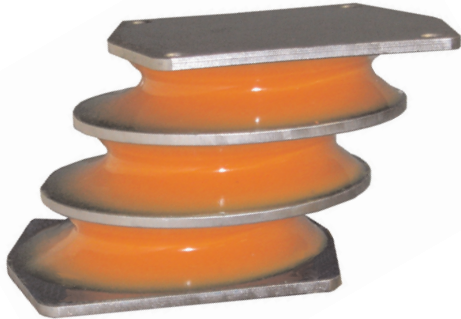

- ▶ Stemco Gaff Polyurethane formulation for this application has been enhanced for strength and load capacity.
- ▶ Exclusive Geometry design for improved Ride Comfort, and superior durability.
- ▶ Improved bonding process to increase strength between the plates and polyurethane to support the demanding conditions on the vocational applications with these suspensions.

13721

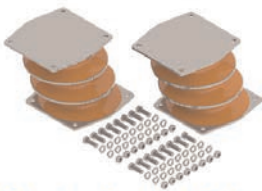

INCLUDES

QTY 2 13601

QTY 16 Bolts 7/16" x 1 1/4" UNF

QTY 16 Lock Nuts 7/16" UNF

QTY 32 Flat Washer 7/16"

Bolster Spring Pair

13722



INCLUDES

QTY 2 13601

QTY 1 13611

QTY 16 Bolts 7/16" x 1 1/4" UNF

QTY 16 Lock Nuts 7/16" UNF

QTY 32 Flat Washer 7/16"

Bolster Spring Kit

STEMCO GAFF recommends inspecting all other suspension components for signs of wear & excessive play, replace as needed. When replacing Bolsters best practice is to replace all four bolsters at same time.

STEMCO GAFF recommends to inspect and replace as needed the Auxiliary Pad, its minimum height should be 3 1/2". The kits include bolts, always install bolts facing thread out of the bolster, make sure all bolster spring bolts are tightened to 60 ft-lb.

STEMCO GAFF Bolsters have proven extended durability to previous product, and superior handling of the loads & severe vocational applications, without affecting ride comfort.

STEMCO GAFF special formulated polyurethane performs exceptionally at maintaining alignment, transferring acceleration and braking forces, and providing stability & ride comfort.



The first step in using STEMCO Kaiser products is SAFETY FIRST SAFETY ALWAYS. Please take a moment to make sure these safety precautions are in place. Some components are heavy! For your protection wear safety shoes, safety glasses, safety gloves, use proper lifting techniques and secure the unit before work begins.

BOLSTER SPRING



Durability



Performance



Capability

Bolster Spring

13601

HN® Suspension

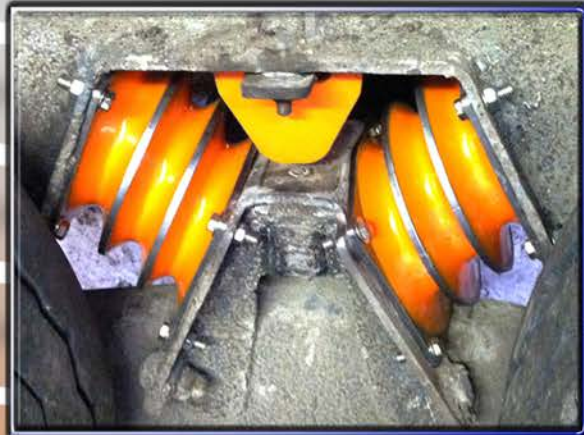

**STEMCO GAFF replacement parts compatible with:
HENDRICKSON® HN® 402/460/462/522 SERIES**



13722



Bolster Spring Kit

INCLUDES

- QTY 2 13601
- QTY 1 13611
- QTY 16 Bolts 7/16" x 1 1/4" UNF
- QTY 16 Lock Nuts 7/16" UNF
- QTY 32 Flat Washer 7/16"

13721



Bolster Spring Pair

INCLUDES

- QTY 2 13601
- QTY 16 Bolts 7/16" x 1 1/4" UNF
- QTY 16 Lock Nuts 7/16" UNF
- QTY 32 Flat Washer 7/16"

**STEMCO GAFF replacement parts compatible with:
HENDRICKSON® HAULMAAX®**

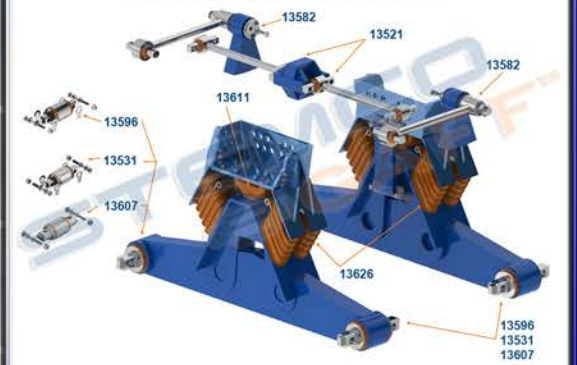

BOLSTER SPRING KIT

13626

HAULMAAX®



A Higher Standard of Performance.™
an EnPro Industries company

Heavy Suspension Components



13721

INCLUDES
 QTY 2 13601
 QTY 16 Bolts 7/16" x 1 1/4" UNF
 QTY 16 Lock Nuts 7/16" UNF
 QTY 32 Flat Washer 7/16"

Bolster Spring Pair

13722

INCLUDES
 QTY 2 13601
 QTY 1 13611
 QTY 16 Bolts 7/16" x 1 1/4" UNF
 QTY 16 Lock Nuts 7/16" UNF
 QTY 32 Flat Washer 7/16"

Bolster Spring Kit

Torque Rod Bushing

13518 OEM# 44697
13520 OEM# 44695
13521 OEM# 47691
13582 OEM# 64697-000

Beam End Bushing Kits

13531 OEM# 34013-087L
13596 OEM# 34013-088L
83596 OEM# 34013-088L
13607 OEM# 34013-087L

Beam End Bushings

13501 OEM# 6969
13506 OEM# 45900-000
13553 OEM# 29878-1
13545 OEM# 10363-00L

Beam End Adapter

13502 OEM# 45000-013
13507 OEM# 45000-007
13547 OEM# 21407

Center Bushing

13500 OEM# 6664-000L
13534 OEM# 30437-000L
13543 OEM# 22282-00L
13505 OEM# 49400-000

Beam Bushing Kit

13504 OEM# for 340
13509 OEM# for 380
13548 OEM# for 400

13649

Overload Cushion

13650

Load Pad

13592

Vertical Bushing

13611

Auxiliary Load Spring

Miscellaneous Components

18006

18455

18005

18848

18905

40095

Ask your local distributor about other STEMCO GAFF products.

