

MANUAL

CONTENTS:

- Page 1 Specifications
- 2 Warning Information
- 3 Parts List
- 4-7 Assembly Instructions
- 8 Operating Instructions and Preventative Maintenance
- 9 Replacement Parts List
- 10 Warranty Information

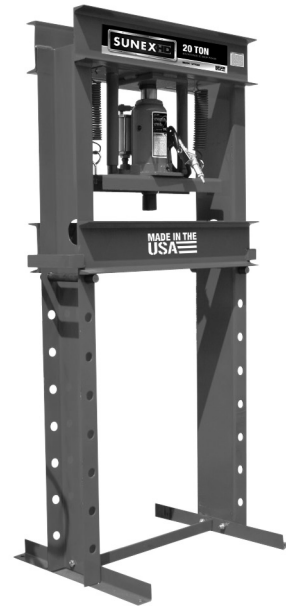

PRESS SPECIFICATIONS

| Sunex Part No. | Total Height | Inside Width | Press Feet Length | Bed Width | Ram Stroke | Pin Diameter | Press Plates Included |
|----------------|--------------|--------------|-------------------|-----------|------------|--------------|-----------------------|
| 5712 | 61.5" | 20" | 26" | 8.75" | 5" | .75" | Y(2) |
| 5720 | 64.5" | 24.5" | 26" | 11.25" | 5.125" | 1" | Y(2) |
| 5720AH | 64.5" | 24.5" | 26" | 11.25" | 5.125" | 1" | Y(2) |

WARNING INFORMATION



This is the safety alert symbol. It is used to alert you to potential personal injury hazards. Obey all safety messages that follow this symbol to avoid possible injury or death.

WARNING

WARNING: Indicates a hazardous situation which, if not avoided, could result in death or serious injury.



IMPORTANT: READ THESE INSTRUCTIONS BEFORE OPERATING

BEFORE USING THIS DEVICE, READ THIS MANUAL COMPLETELY AND THOROUGHLY, UNDERSTAND ITS OPERATING PROCEDURES, SAFETY WARNINGS AND MAINTENANCE REQUIREMENTS.

It is the responsibility of the owner to make sure all personnel read this manual prior to using the device. It is also the responsibility of the device owner to keep this manual intact and in a convenient location for all to see and read. If the manual or product labels are lost or not legible, contact Sunex for replacements. If the operator is not fluent in English, the product and safety instructions shall be read to and discussed with the operator in the operator's native language by the purchaser/owner or his designee, making sure that the operator comprehends its contents.

THE NATURE OF HAZARDOUS SITUATIONS

WARNING

The use of shop presses and their accessories is subject to certain hazards that cannot be prevented by mechanical means, but only by the exercise of intelligence, care, and common sense. It is therefore essential to have owners and personnel involved in the use and operation of the equipment who are careful, competent, trained, and qualified in the safe operation of the equipment and its proper use. Examples of hazards are components being pressed and breaking resulting in flying parts that are not secured from hitting the operator, the set up in the press is not secure, guards, shields or protective blankets are not used, improperly securing adjustments on the press, overloading and off-center loads.

METHODS TO AVOID HAZARDOUS SITUATIONS

WARNING



- Read, study, understand and follow all instructions before operating this press.



- Always wear safety goggles, users and bystanders.

- Parts being pressed may splinter, shatter, or be ejected from the press at a dangerous rate of speed. Because there are a variety of press applications, it is the responsibility of the press owner to provide adequate guards, eye protection and protective clothing to the press operator.
- Visual inspection of the press should be made before use, checking for signs of cracked welds, bent bed pins, loose or missing bolts, leaks, or any other structural damage. Corrections must be made before using the press.
- Do not go near leaks. High pressure hydraulic fluid can puncture skin and cause serious injury, gangrene, or death. If injured, seek emergency medical help as immediate surgery is required to remove the fluid.
- Prior to use make sure the press is securely anchored to a concrete floor.
- Keep hands, arms, feet, and legs out of work area. Accidental slippage can result in personal injury.
- Always use an accurate force gauge to measure pressing force.
- Do not exceed the rated capacity or tamper with the pressure/force settings. When attachments and adapters are used the rated capacity of the system shall be no greater than the rated capacity of the lowest rated component or combination of components that make up the system.
- Avoid off-center loads. Offset loads can damage ram and may cause load to eject at a dangerous rate of speed. Do not use any spacer or extender between the press ram plunger and the item being pressed. If there is not enough ram stroke, adjust the height of the movable bolster.
- Remove all loads from movable bolster before attempting to adjust bolster height. Beware of possible falling bolster.
- Press only on loads supported by movable bolster and press plates included. Do not support loads on floor or press frame legs.
- When using any accessories such as press plates or arbor plates, be certain they are centered on the movable bolster and in full contact with both sides of the bolster.
- Before applying load, be certain all movable bolster supporting pins are fully engaged. Verify lift cables (if equipped) are slack before pressing on the bolster.
- Always use a bearing shield when pressing bearings.
- Use caution when positioning work to be pressed to ensure the item to be pressed cannot be ejected at a dangerous rate of speed.
- Release hydraulic pressure before loosening any fittings.
- Maintain proper hydraulic fluid levels.
- Do not make any alterations to the press.
- Failure to heed and understand these markings may result in serious or fatal personal injury and/or property damage.



WARNING: This product can expose you to chemicals including nickel which is known to the State of California to cause cancer and birth defects or other reproductive harm.

CONSEQUENCES OF NOT AVOIDING HAZARDOUS SITUATIONS

WARNING

Failure to read this manual completely and thoroughly, failure to understand its OPERATING INSTRUCTIONS, SAFETY WARNINGS, MAINTENANCE INSTRUCTIONS and comply with them, and failure to comply with the METHODS TO AVOID HAZARDOUS SITUATIONS could cause accidents resulting in serious or fatal personal injury and/or property damage.

PARTS LIST

ESTIMATED ASSEMBLY TIME: 30 MINUTES

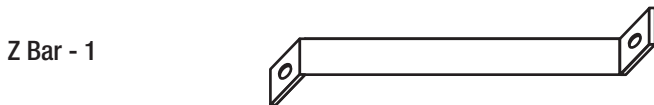
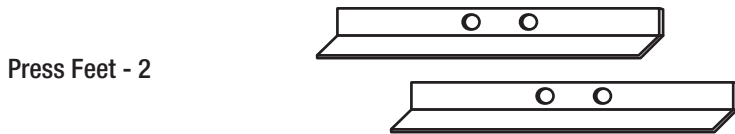
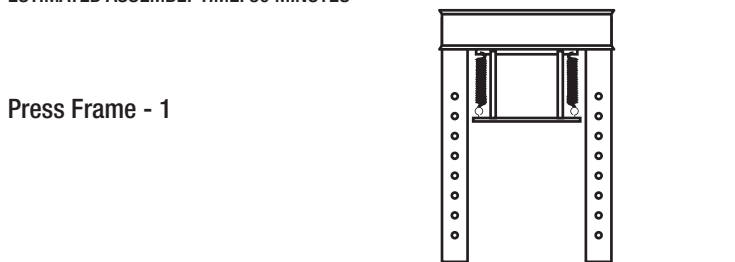

Power Unit - 1 (5712 & 5720 ONLY)

5712 - 12 Ton Power Unit
 5720 - 20 Ton Power Unit

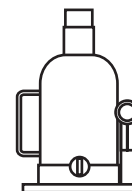

Pneumatic Power Unit - 1 (5720AH ONLY)

5720AH - 20 Ton Pneumatic Power Unit

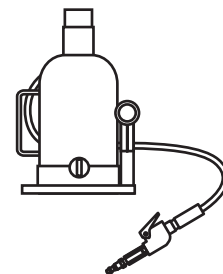

Pump Handle & Extension - 1

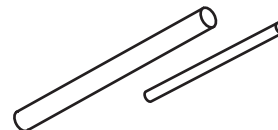

ACCESSORIES

2" Punch - 1

*Accessory only -
 Not needed for assembly*



Bearing Shield - 1

*Accessory only -
 Not needed for assembly*



Press Plates - 2

*Accessory only -
 Not needed for assembly*

5712 - (2) 1" x 2" x 10" Plates
 5720 - (2) 3/4" x 3" x 12" Plates
 5720AH - (2) 3/4" x 3" x 12" Plates

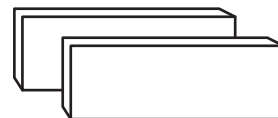

TOOLS NEEDED

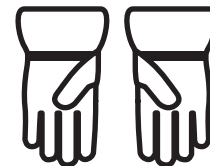
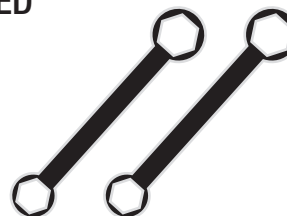

1/2" and 5/16" Box Wrenches

Examine box contents, then proceed with the following instructions.

ASSEMBLY INSTRUCTIONS

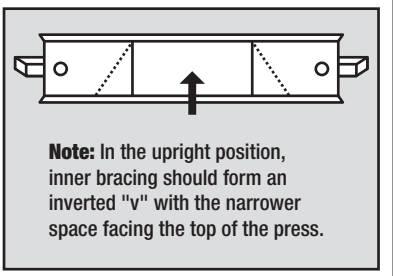
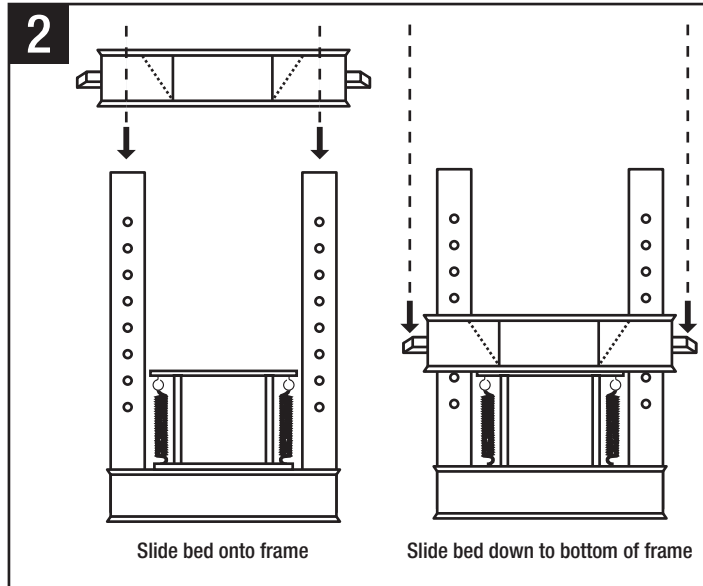
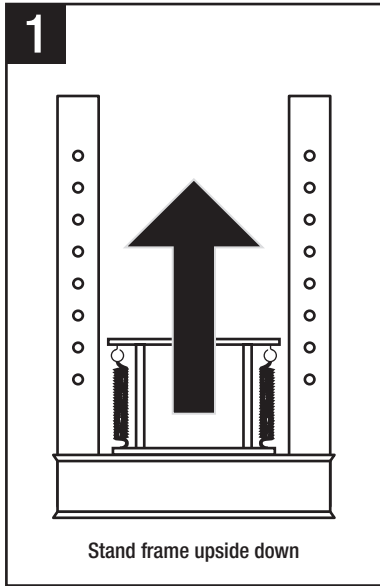

⚠ WARNING

Be aware of jagged edges on frame. Not all welds are smooth. Press bed can pinch or crush fingers. Wear safety gloves.

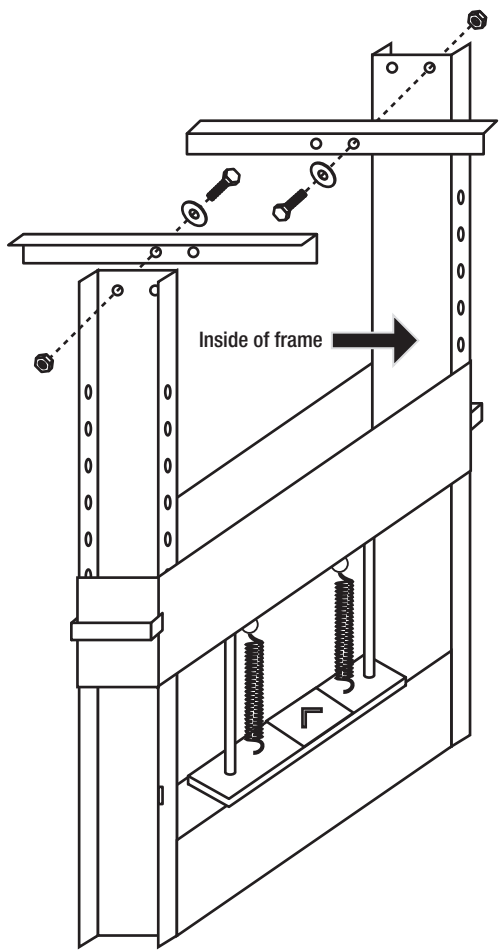
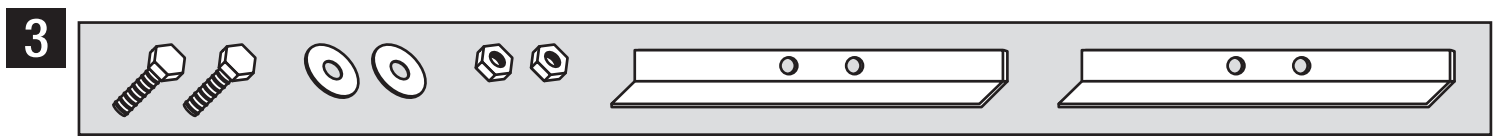

⚠ WARNING

Leg ends and press feet are sharp and potentially dangerous. Wear safety gloves and safety goggles.

Note: Position press feet on each side of the press. Attach one bolt, washer and nut on each side. Bolts should be attached *OFFSET* from one another.

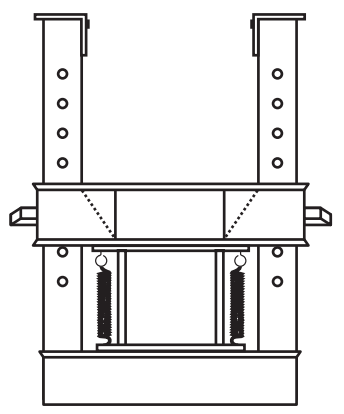
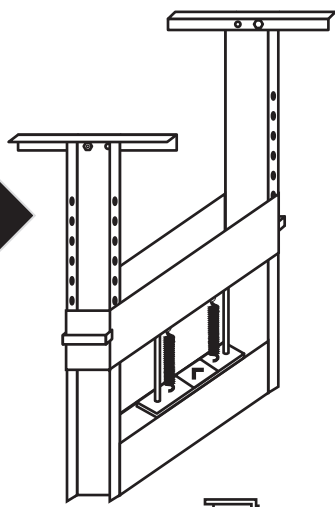

Front view

ASSEMBLY INSTRUCTIONS CONTINUED

4

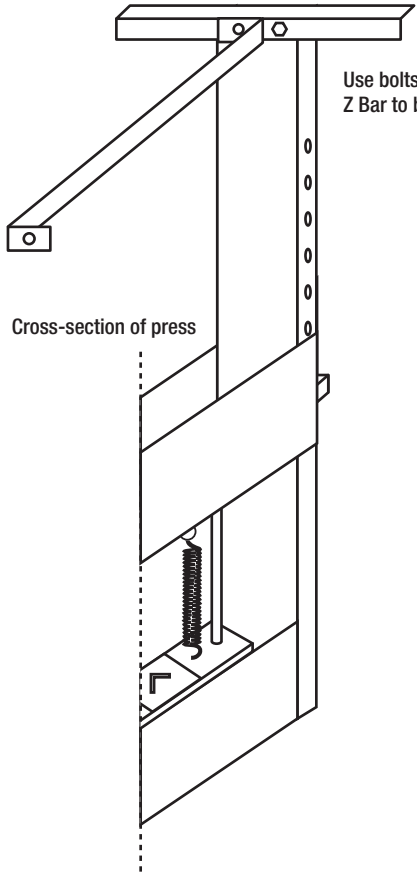
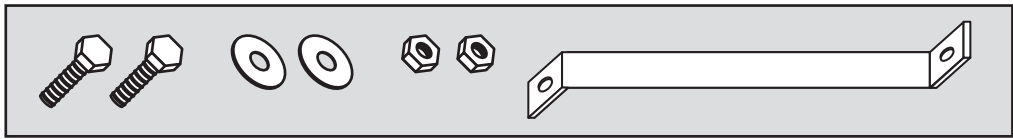

Use bolts, washers and nuts to attach Z Bar to both sides of the press.

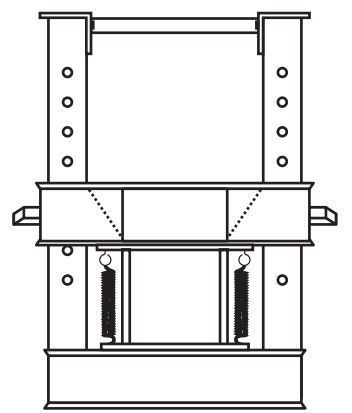
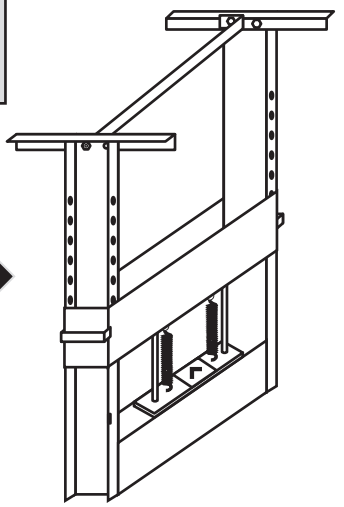
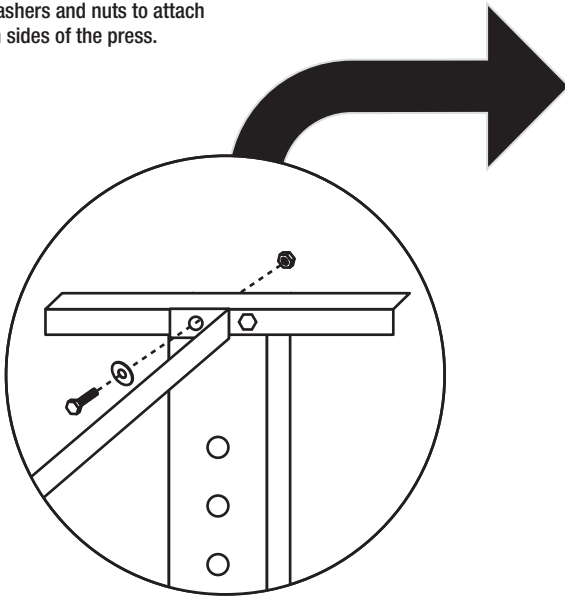

Front view

Note: Check all bolts for tightness. If press rocks, or is not level, loosen press feet slightly to compensate and retighten.

5

⚠ WARNING

Bed must be at the **BOTTOM** of the frame before proceeding to the next step.

Note: When sliding bed to frame bottom, **DO NOT** use bed handles.

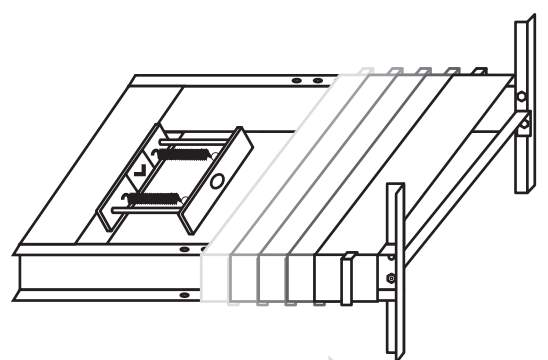
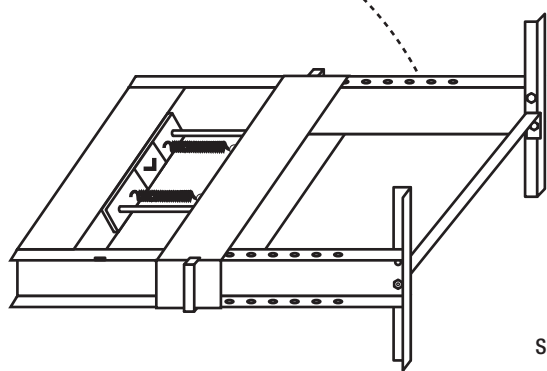
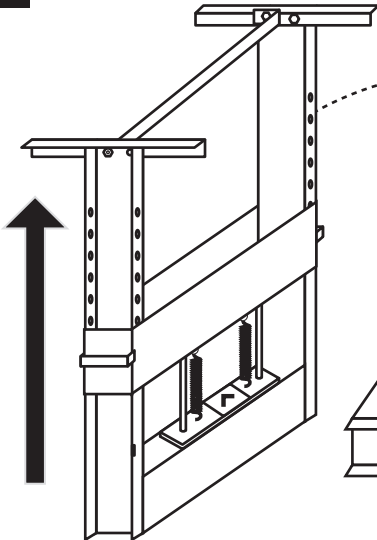

Slide bed down to bottom of frame →

ASSEMBLY INSTRUCTIONS CONTINUED

6

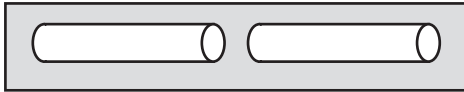

WARNING

Pins must be COMPLETELY through BOTH SIDES of frame.

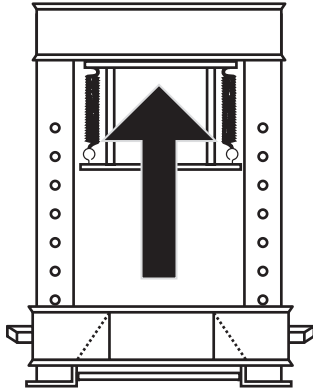

Stand unit upright

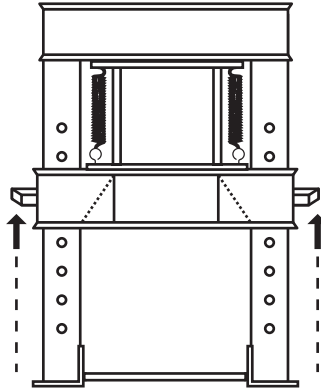

Slide bed above holes and *hold in place*

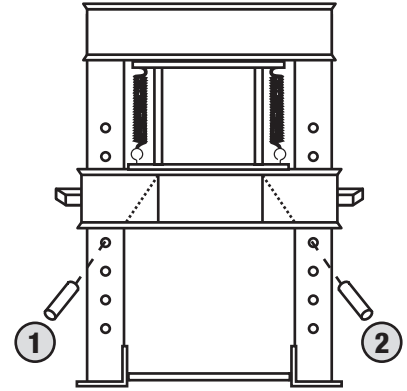

Secure pins underneath bed, one at a time

PROCEDURE FOR BLEEDING AIR

7

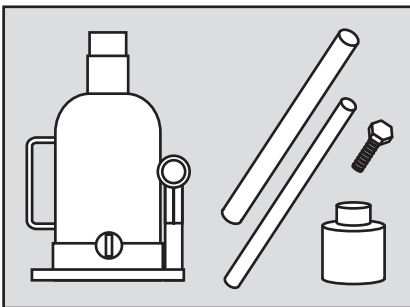

1. Align power unit with "V" in top plate (opening in "V" faces the front side of the press).

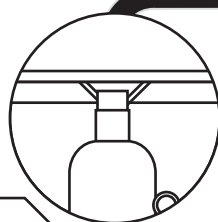

2. Insert punch into receptacle UNDER bottom plate.

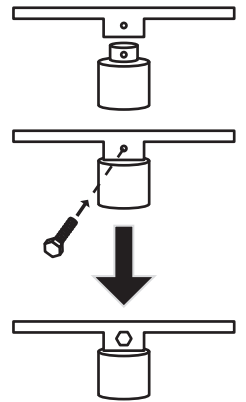

3. Tighten screw to secure punch.

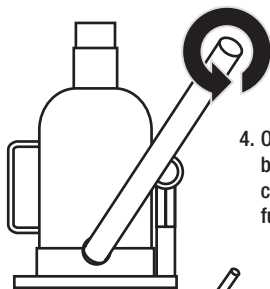

4. Open the release valve by rotating the handle counterclockwise ONE full turn.

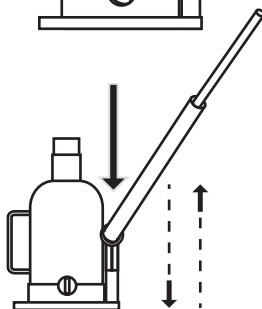

5. Place pump in cradle.
Pump 6 full strokes to purge air.

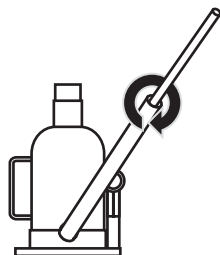

6. Close valve.

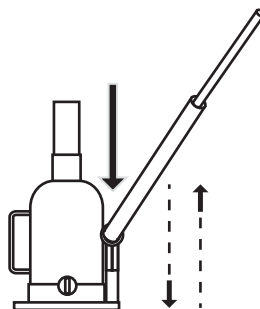

7. Pump until unit reaches full extension.
Keep pumping under load to purge all air.

Note: If the unit responds immediately to pump action, it is free of air and ready for operation. If not, repeat procedure.

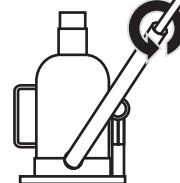

8. Open valve and push ram to its lowest position.

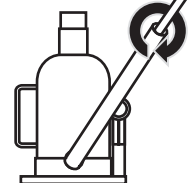

9. Close valve and operate normally.

PUMP INSTRUCTIONS FOR 5712 & 5720

8

1. Place the handle on the release valve and rotate clockwise until the valve is closed (hand tighten only).

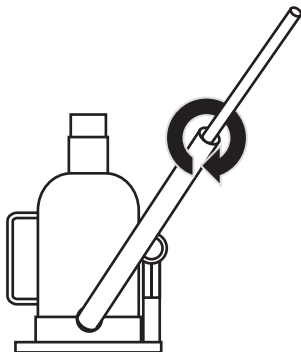

2. Place the pump handle in the cradle. Move pump handle up and down to lower the carriage and apply force to the item being pressed.

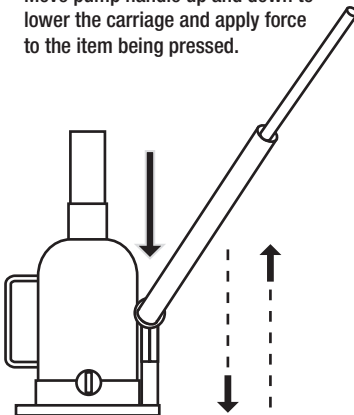

3. To release pressure, remove the pump handle from the cradle and use the handle to slowly turn the release valve counterclockwise. The power unit cylinder will retract and the press cradle will return to the stored position.

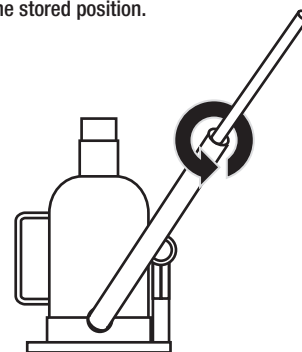

Note: When not in use, store power unit with the piston in the fully retracted position and the release valve closed.

PUMP INSTRUCTIONS FOR 5720AH

8-AH

TO OPERATE MANUALLY

5720AH can be operated manually or with pneumatic/ hydraulic assist. See step 8 (#1, 2, & 3) for manual operating instructions.

TO OPERATE WITH PNEUMATIC/ HYDRAULIC ASSIST

After step 7 (#9): Ensure the oil level is just below the oil filler plug hole. Re-install the oil filler plug. Pour a teaspoon of good quality, air tool lubricant into the air supply inlet of the lift control valve.

Connect to air supply and operate for 3 seconds to evenly distribute lubricant. Check to ensure that the pump operates smoothly before putting into service. Replace worn or damaged parts and assemblies as needed with manufacturer's authorized replacement parts.

1. Place the handle on the release valve and rotate clockwise until the valve is closed (hand tighten only).

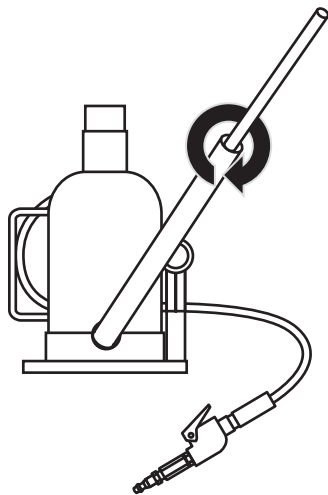

2. To begin pneumatic operation, squeeze air hose trigger until ram comes into contact with the item to be pressed.

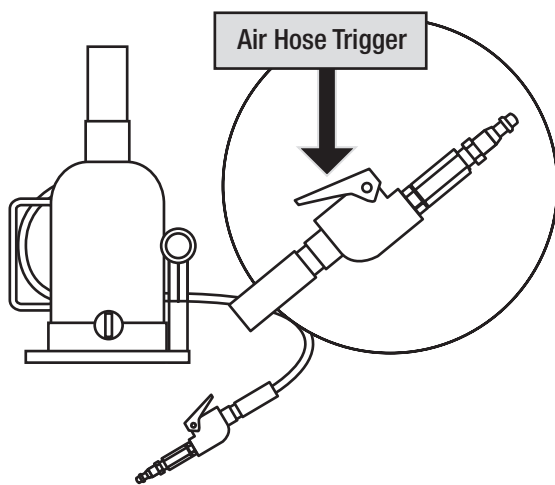

3. To end pneumatic operation, release the grip on the air hose trigger.

⚠ WARNING

Never wire, clamp or otherwise disable the lift control valve to function by any means other than by using the operator's hand.

OPERATING INSTRUCTIONS



This is the safety alert symbol used for the OPERATING INSTRUCTIONS section of this manual to alert you to potential personal injury hazards. Obey all instructions to avoid possible injury or death.

1. Press operator and all observers must wear eye protection, protective clothing and shoes before operating the press.
2. Keep body parts out of work area during a pressing operation. Make sure all guards are properly adjusted and secured.
3. Consider the work to be accomplished and then determine:
 - a. The amount of ram stroke required to accomplish the job.
 - b. The correct punch or adapter to be used and then install on the ram.
 - c. The distance the ram should be from the component to be pressed and the required press bed height to support the component.
 - d. Any adapters used for pressing must have a maximum tonnage rating equal to or higher than the rated capacity of the press.
4. Raise the press bed to the required height by first removing the press bed pins. Once the pins are removed, raise or lower the press bed to the required height. The holes in the press bed must align with the closest holes in the press frame uprights before the bed pins can be installed. Make sure the press bed pins are fully engaged with the holes in the press bed or the channel flanges or back sides of the press bed and the holes in the paralleled uprights on both sides of the press frame. **DO NOT ATTEMPT ANY PRESS WORK WITHOUT FULL ENGAGEMENT OF ALL PINS.**
5. Prepare set up of the component to be pressed and appropriate adapters or fixtures to adequately support the component during the pressing operation. Make sure set up is stable and secure, the ram force is straight, and parts being pressed cannot slip out or break. The owner of the press must provide shielding that is practical and necessary for each application.
6. Position appropriate guarding (protective shield, protective blanket, etc.) between work setup and press operator.
7. Never attempt to raise or lower the press bed until the work piece and adaptors are removed from the bed.
8. Inspect the length of the bed lifting cables (if so equipped) every 3 months to make sure they are not frayed, worn, crushed or stretched. Replace, adjust or repair before using press.
9. Air may become trapped in the hydraulic jack during shipping and/or handling. An air trapped jack will not pump up the required incremental pump strokes or pumping may feel spongy. Follow these instructions to purge air from the jack's hydraulic system?
 - a. Turn the jack's release valve with the handle provided all the way in a clockwise direction until tight. Now turn the release valve two full rotations in a counterclockwise direction.
 - b. Now put the pump handle in the pump handle receiver and activate the jack approximately 15 times.
 - c. Close the release valve by turning it clockwise until it stops. Pump the jack until the ram reaches maximum height.
 - d. Repeat steps "a" through "c" until all the air is purged out of the system.

PREVENTATIVE MAINTENANCE



This is the safety alert symbol used for the PREVENTATIVE MAINTENANCE section of this manual to alert you to potential personal injury hazards. Obey all instructions to avoid possible injury or death.

1. Inspect the press before each use for cracks, breaks, signs of damage/fatigue, hydraulic or air leaks, loose or missing hardware or modifications. Do not use the press if any of the above conditions exist until the conditions are corrected.
2. The location of the press should not expose it to inclement weather, corrosive vapors, abrasive dust, or any harmful elements.
3. Lubricate moving parts once a month with a general purpose marine grease. Do not lubricate press accessories, press bed work surface or ram.
4. It should not be necessary to refill or top off any pump reservoirs with hydraulic fluid unless there is an external leak. External leaks, if caused from other than tightening hydraulic components, must be handled by calling Sunex customer service. **NEVER USE ALCOHOL, HYDRAULIC BRAKE FLUID OR TRANSMISSION FLUID IN THE HYDRAULIC SYSTEM.** Use Chevron Hydraulic Oil AW ISO 32 or its equivalent Unocal Unax AW 150.
5. Every press owner is responsible for keeping press labels and owner's manual readable. Contact Sunex for replacement labels and manual if unreadable.

REPLACEMENT PARTS LIST

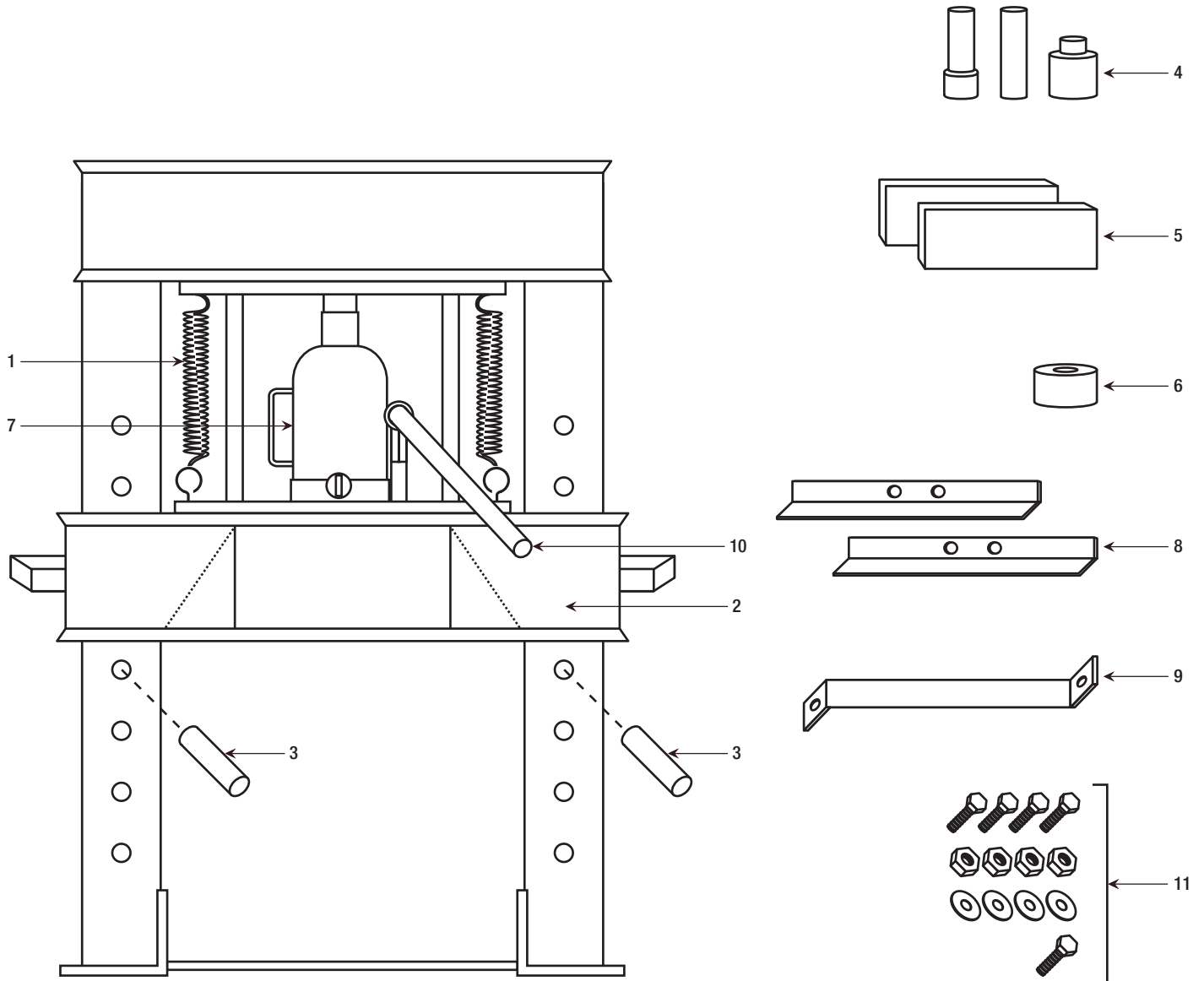

| ITEM NO. | SUNEX PART NO. | DESCRIPTION | QTY. | ITEM NO. | SUNEX PART NO. | DESCRIPTION | QTY. |
|----------|----------------|---|------|-----------|----------------|--------------------------------|-------|
| 1 | RSCBP1214 | Spring | 2 | 8 | RS12FT | Press Feet (5712) | 2 |
| 2 | | Press Bed (5712) | 1 | | RS20FT | Press Feet (5720 & 5720AH) | 2 |
| | | Press Bed (5720 & 5720AH) | | 9 | RS550049 | Z Bar (5712) | 1 |
| 3 | RS550012 | Press Pin (5712) | 2 | | RS550051 | Z Bar (5720 & 5720AH) | 1 |
| | RS550034 | Press Pin (5720 & 5720AH) | 2 | 10 | RS49HDL12 | Power Unit Handle | 1 |
| 4 | 52PPK3 | 3 Piece Punch Kit | 1 | 11 | RS5212BK | Press Hardware Kit | 1 set |
| 5 | RS550041 | Press Plate | 2 | | | 1/2"-13 x 1-1/2" Hex Head Bolt | 4 |
| 6 | RSBS1 | Bearing Shield | 1 | | | 1/2" Nut | 4 |
| 7 | 12BJP | 12 Ton Power Unit (includes handle) | 1 | | | Washer | 4 |
| | 20BJP | 20 Ton Power Unit (includes handle) | 1 | | | 5/16"-13 x 1" Hex Head Bolt | 1 |
| | 20ABJP | 20 Ton Pneumatic Power Unit (includes handle) | 1 | not shown | RS5712LK | Label Kit | 1 set |
| | | | | not shown | RS5720LK | Label Kit | 1 set |
| | | | | not shown | RS5720AHLK | Label Kit | 1 set |

Only items identified by part number are available separately.