



# SUPERLIFT®

## S U S P E N S I O N

### Superlift Dual Steering Stabilizer system for 2003 and Newer 3/4- and 1-ton Dodge Ram 4WD INSTALLATION INSTRUCTIONS

#### INTRODUCTION

Installation requires a professional mechanic. Prior to beginning, inspect the vehicles steering, driveline, and brake systems, paying close attention to the suspension link arms and bushings, anti-sway bars and bushings, tie rod ends, pitman arm, ball joints and wheel bearings. Also check the steering sector-to-frame and all suspension-to-frame attaching points for stress cracks. The overall vehicle must be in excellent working condition; repair or replace all worn parts.

**Read instructions several times before starting. Be sure you have all needed parts and know where they install. Read each step completely as you go.**

#### NOTES:

- An arrow on diagrams indicates which direction is toward the front of the vehicle.
- A foot-pound torque reading is given in parenthesis ( ) after each appropriate fastener.
- Do not fabricate any components to gain additional suspension height.
- Prior to drilling or cutting, check behind the surface being worked on for any components that could be damaged.
- After drilling, file smooth any burrs and sharp edges.
- Prior to operating a torch or saw, protect any heat-sensitive components located in the immediate area by covering them with a water-saturated cloth. Most undercoating are flammable but can be extinguished using a water-filled spray bottle. Have a spray bottle and an ABC rated fire extinguisher on hand.
- Paint or undercoat all exposed metal surfaces.
- Prior to attaching components, be sure all mating surfaces are free of grit, grease, undercoating, etc.
- A factory service manual should be on hand for reference.
- Use the check-off box "☐" found at each step to help you keep your place. Two "☐☐" denotes that one check-off box is for the driver side and one is for the passenger side. Unless otherwise noted, always start with the driver side.

**PARTS LIST ...** The part number is stamped into each part or printed on an adhesive label. Identify each part and place the appropriate mounting hardware with it.

<b>PART NO</b>	<b>DESCRIPTION</b> (Qty.- if more than one)	<b>NEW ATTACHING HARDWARE</b> (Qty.)
55-01-92670	.....driver side bracket .....	(1) 1/2" shock stud (2) 3/8" x 1" bolt (2) 3/8" nyloc nut
55-02-92670	.....passenger side bracket .....	(1) 1/2" shock stud (2) 3/8" x 1" bolt (2) 3/8" nyloc nut
55-05-92670	.....center bracket.....	(2) 5/16" x 1-1/4" x 2-3/4" U-bolt (4) 5/16" nyloc nut (1) 1/2" x 2" bolt (2) 1/2" x 2-1/2" bolt (3) 1/2" stover nut (2) 1/2" USS flat washer (1) 5/8" OD x 1/2" ID x 0.470" sleeve (2) 5/8" OD x 1/2" ID x 1-1/2" sleeve
81160	.....(2) steering stabilizer .....	(2) hardware pack and cable tie
0034	.....Superlift badge .....	alcohol wipe pad
00461	.....decals, "Warning To Driver"	

**INSTALLATION PROCEDURE**

**1) PREPARE VEHICLE...**  
 Place vehicle in Park and engage parking brake. Position the steering wheel so that the tires are pointed straight ahead.

**2) REMOVE FACTORY COMPONENTS...**  
 Remove and discard the factory steering stabilizer, if equipped.  
 [DIAGRAM 1] Using a cut-off wheel or similar tool, remove the factory steering stabilizer mount tabs as shown. After cutting, file smooth any rough edges.

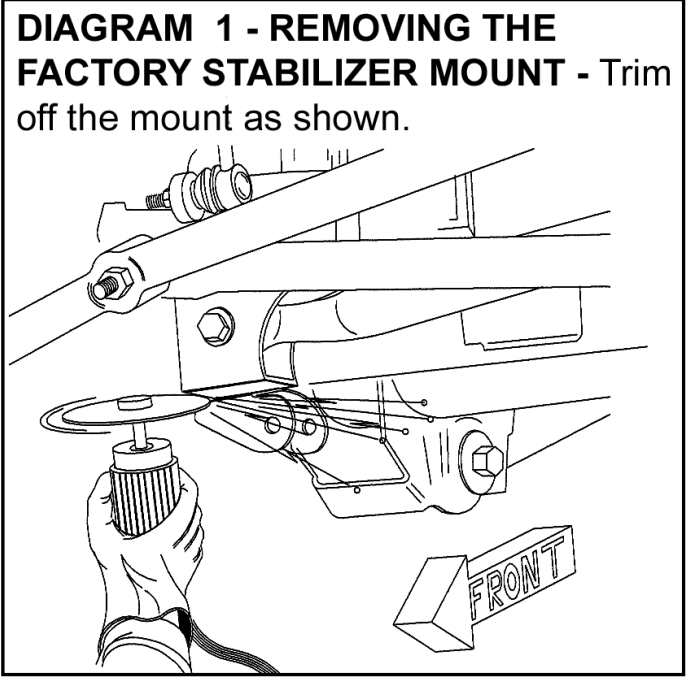

**3) INSTALL STABILIZER BRACKETRY...**  
 [DIAGRAM 2] On each side, install the 1/2" stabilizer mounting studs on the #55-01-92670 driver side and #55-02-92670 passenger side brackets as shown. Tighten (57).

- [DIAGRAM 2] On each side, position the #55-01-92670 driver side and #55-02-92670 passenger side brackets inside the lower link arm axle brackets as shown. The brackets should be positioned so that the shock studs are offset to the outside of the vehicle (towards the tires) as shown. Clamp the "01" and "02" brackets in place.

- On each side, using the two holes in the factory lower link axle brackets as a template, drill two holes in the "01" and "02" brackets using a 13/32" drill bit.

- Install the supplied 3/8" x 1" bolts and nyloc nuts through the holes drilled previously and tighten (23).

- [DIAGRAM 3] Position the center bracket (#55-05-92670) as shown, with the tab on the bottom of the bracket lined up with the factory stabilizer mount hole in the tie rod. Install the 5/8" OD x 0.470" long sleeve in the tie rod hole, then install the supplied 1/2" x 2" bolt through the tie rod, sleeve, and "03" bracket. The bolt should be installed from the top. Secure using the supplied 1/2" stover nut. Snug, but do not fully tighten at this time.

- [DIAGRAM 4] Install the two supplied 5/16" U-bolts on each side of the "03" bracket as shown and secure using the supplied 5/16" nyloc nuts.

- Tighten the 1/2" bolt (57) and 5/16" nuts (14).

#### 4) INSTALL #81160 STEERING STABILIZERS...

- If the optional shock boots have been purchased, install now and secure with the supplied zip ties.
- Install the supplied 5/8" OD x 1.5" long sleeves in the bushings on the rod ends of each #81160 steering stabilizer.
- Install the rod end of each stabilizer to the bottom of the "05" bracket using the 1/2" x 2-1/2" bolts; the opposite end attaches to the studs on the "01" and "02" brackets. Note that the bolts should face down and the 1/2" USS washer should be on the nut side.

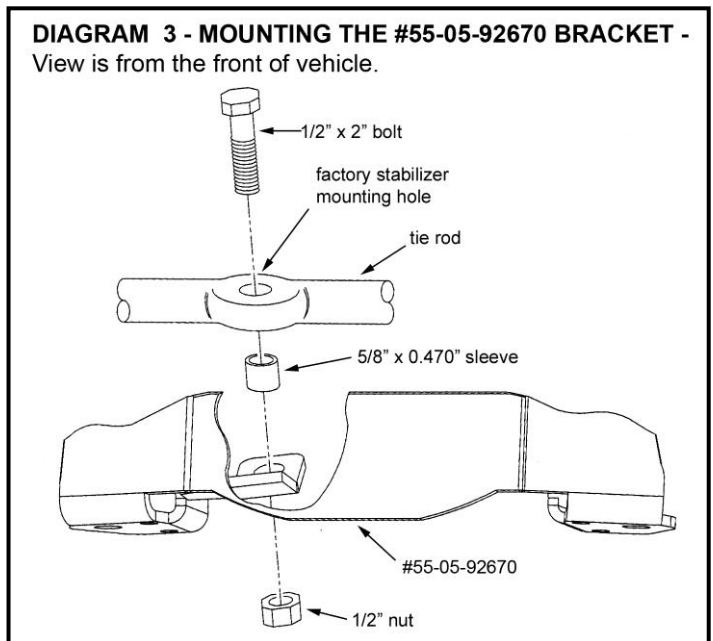
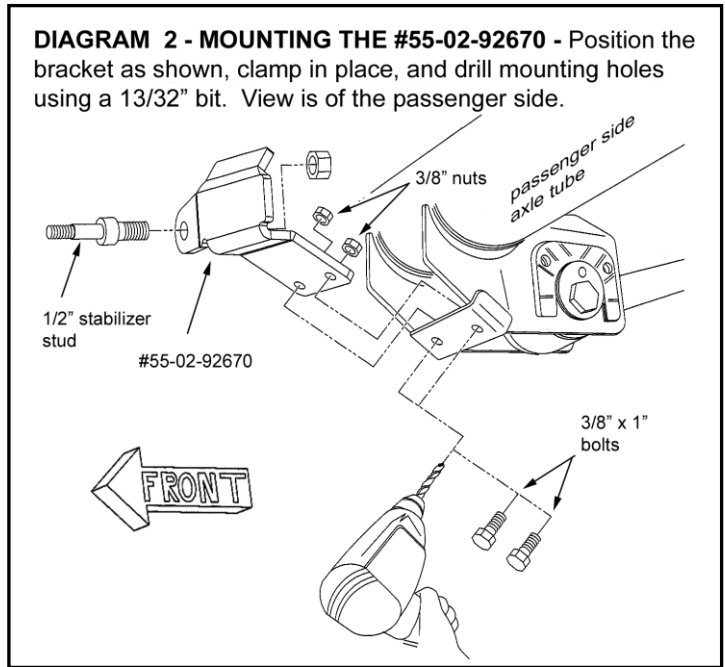

- Loosely secure the stud ends with the supplied 1/2" standard nuts and 1/2" x 2-1/2" bolts with the supplied 1/2" Stover nuts.
- Tighten the rod ends of the stabilizers until the bushings swell slightly, followed by the opposite ends of each stabilizer (57).

**5) FINAL PROCEDURES...**

- Cycle the steering lock-to-lock and check clearance between the stabilizer bodies and the tie rod / drag link assembly. Pay close attention to ensure each stabilizer is not bottoming or topping out throughout the steering cycle.
- Check all hardware for adequate torque and clearance.
- Check the steering, suspension, and brake systems for proper operation, tightness, and adequate clearance.