



# SUPERLIFT®

## S U S P E N S I O N

### Superlift 4" standard [lift system](#) for 2005 and Newer FORD F-250 / F-350 SUPER DUTY 4WD INSTALLATION INSTRUCTIONS

#### INTRODUCTION

Installation requires a professional mechanic. Prior to beginning, inspect the vehicles steering, driveline, and brake systems, paying close attention to the suspension link arms and bushings, anti-sway bars and bushings, tie rod ends, pitman arm, ball joints and wheel bearings. Also check the steering sector-to-frame and all suspension-to-frame attaching points for stress cracks. The overall vehicle must be in excellent working condition; repair or replace all worn parts.

**Read instructions several times before starting. Be sure you have all needed parts and know where they install. Read each step completely as you go.**

#### NOTES:

- Front end realignment is necessary.
- An arrow on diagrams indicates which direction is toward the front of the vehicle.
- A foot-pound torque reading is given in parenthesis ( ) after each appropriate fastener.
- Do not fabricate any components to gain additional suspension height.
- Prior to drilling or cutting, check behind the surface being worked on for any wires, lines, or hoses that could be damaged.
- After drilling, file smooth any burrs and sharp edges.
- Prior to operating a torch or saw, protect any heat-sensitive components located in the immediate area by covering them with a water-saturated cloth. Most undercoating are flammable but can be extinguished using a water-filled spray bottle. Have a spray bottle and an ABC rated fire extinguisher on hand.
- Paint or undercoat all exposed metal surfaces.
- Prior to attaching components, be sure all mating surfaces are free of grit, grease, undercoating, etc.
- A factory service manual should be on hand for reference.
- Use the check-off box "☐" found at each step to help you keep your place. Two "☐☐" denotes that one check-off box is for the driver side and one is for the passenger side. Unless otherwise noted, always start with the driver side.

**PARTS LIST ...** The part number is stamped into each part or printed on an adhesive label. Identify each part and place the appropriate mounting hardware with it.

<b>PART NO</b>	<b>DESCRIPTION</b> <small>(Qty.- if more than one)</small>	<b>NEW ATTACHING HARDWARE</b> <small>(Qty.- if more than one)</small>
----------------	---	--

01-294 .....(2) front coil spring, diesel
---

**OR**

01-295.....(2) front coil spring, gas
---------------------------------------

55-01-9024 .....compression stop bracket,..... front, driver side	(1) 3/8" x 1-1/4" bolt (1) 3/8" x 1" bolt (1) 3/8" USS washer (2) 3/8" nyloc nut
55-02-9024 .....compression stop bracket,..... front, passenger side	(1) 3/8" x 1-1/4" bolt (1) 3/8" x 1" bolt (1) 3/8" USS washer (2) 3/8" nyloc nut
55-13-9024.....radius arm drop bracket,..... driver side	(2) 18mm x 130mm bolt (4) 18mm washer (2) 18mm nyloc nut (2) 1-1/8" OD x 2-3/4" sleeve (1) 1/2" x 1-1/4" bolt (1) 1/2" SAE washer (1) 1/2" nyloc nut
55-14-9024.....radius arm drop bracket,..... passenger side	(2) 18mm x 130mm bolt (4) 18mm washer (2) 18mm nyloc nut (2) 1-1/8" OD x 2-3/4" sleeve (1) 1/2" x 1-1/4" bolt (1) 1/2" SAE washer (1) 1/2" nyloc nut
55-03-9024.....steering stabilizer drop ..... bracket	(1)5/8" x 1-1/2" bolt (1) 5/8" SAE washer (1) nyloc nut (2) 7/16" USS washer (2) poly bushing half
66-04-9024.....(2) anti-sway bar link extension	
55-01-9000.....front track bar bracket	
55-07-9024.....(2) brake line extension bracket ..	(1) 1/4" x 3/4" bolt (1) 1/4" nyloc nut (1) 5/16" x 3/4" bolt (1) 5/16" nyloc nut
55-05-9024.....(2) track bar key	
(2) shock absorber, front .....	(2) shock boot*, yellow (2) hardware pack and cable tie

- (2) shock absorber, rear.....(2) shock boot\*, yellow
- (2) hardware pack and cable tie

\*(Note: Shock boots, if desired, purchased separately)

00461..... decal, "Warning To Driver"

**INSTALLATION PROCEDURE**

**1) PREPARE VEHICLE...**

- Prior to raising the vehicle, disconnect the track bar from its attachment point on the frame and let the bar hang. Save all hardware for re-use.
- Disconnect the anti-sway bar links from their attachment points on the front axle. Save all hardware for re-use.
- Place vehicle in neutral. Raise front of vehicle with a jack and secure a jack stand beneath each frame rail, behind the radius arm mounts. Ease the frame down onto the stands, place transmission in low gear or "park", and chock rear tires. Remove front tires.

**2) CONTINUE DISASSEMBLY...**

- Position a jack so that it supports, but does not raise, the front axle.
- Remove and discard the front shock absorbers. Save the upper bushings for re-use.
- Unbolt the stem end of the front steering stabilizer from the frame mount. Save all hardware for re-use.
- Remove the cotter pin and castellated nut from the drag link where it attaches to the pitman arm. Using the appropriate puller tool, separate the drag link from the pitman arm.
- Unbolt the brackets securing the front brake hoses to the coil spring tower on the frame. Save all hardware for re-use.
- Unbolt the lower brake hose brackets securing the hose to the axle. Save all hardware for re-use.
- Carefully lower the front axle enough to facilitate the removal of the front coil springs. Save the rubber isolators at the top of the coils for re-use.
- Unbolt the factory track bar bracket from the

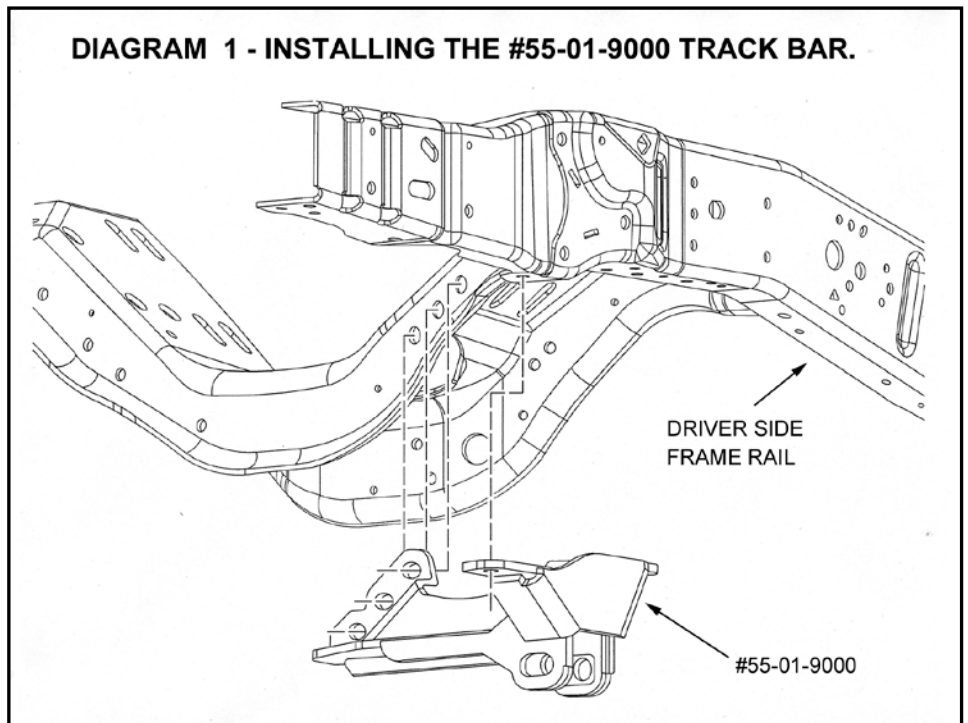

frame. Save all hardware for re-use.

### 3) TRACK BAR BRACKET...

**NOTE:** Inspect the area of the frame crossmember where the track bar bracket attaches. Often there is an excessive amount of undercoating build-up on the crossmember, especially on the back (rearward facing) portion of the crossmember where the undercoating has pooled up. Scrape off any excessive undercoating to prevent the track bar bracket from loosening over time.

- ❑ [DIAGRAM 1] Position the Superlift track bar bracket (#55-01-9000) on the frame in the same place as the original and secure using the factory hardware. There are a total of five bolts; three attached to a retaining tab plus two additional bolts. Once all the bolts are started, tighten (136).

### 4) RADIUS ARMS...

**NOTE:** Perform the following steps one side at a time. Start on the driver side.

**IMPORTANT:** The radius arms have two mounting ears that attach to the axle; one is equipped with a round hole and the other is slotted. The slotted ear of each radius arm is supposed to be attached to the lower axle mount. However, it has been noted that one or both of the radius arms on some trucks are installed with the slotted ear attached to the top mount. It is suspected that this was an assembly line error. Regardless of how the radius arms were attached to the truck during disassembly, they need to be installed with the slotted hole attached to the lower axle mount.

- ❑❑ Unclip the ABS wire from the radius arm and secure it out of the way.
- ❑❑ Verify once again that the axle is supported by the jack, then unbolt the radius arm from the frame and front axle. Save all hardware for re-use.

- ❑❑ [DIAGRAM 2] There are two holes in the sides of the factory radius arm mounts: one is the original radius arm pivot hole and another forward and slightly above the pivot hole. If necessary, enlarge both of these holes using a 3/4" bit.

- ❑❑ Position the radius arm drop bracket (#55-13-9024 driver side and #55-14-9024 passenger side) inside the factory mount on the frame as shown. The part number is stamped on the bracket for

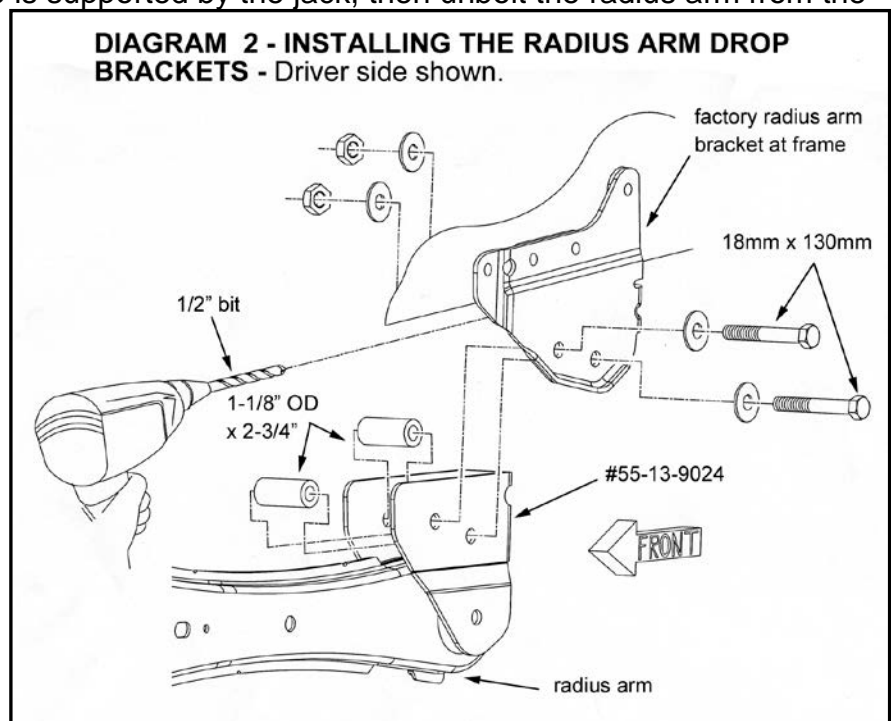

reference; for clarification, the welded seam on each bracket should be positioned on the inboard on the vehicle. Line up the side mounting holes, then using the drop bracket as a template, mark the location of the 1/2" hole to be drilled in the back of the factory mount.

- Remove the bracket and drill the marked location using a 1/2" bit.
- [DIAGRAM 2] Slide the drop bracket back into position and install the supplied 1/2" x 1-1/4" bolt and nyloc nut in the rear hole just drilled. The bolt should be installed from the front. Do not tighten at this time.
- Position the supplied 1-1/8" OD x 2-3/4" sleeves inside the drop bracket as shown in Diagram 2, and line them up with the two mounting holes. Install the supplied 3/4" x 5" bolts with washers through the factory mount, drop bracket, and sleeves. The bolts should be installed from the outside and secured with the remaining 3/4" washers and stover nuts.
- Tighten the 1/2" bolt (57) followed by the 3/4" bolts (200).
- Attach the radius arm to the drop bracket and axlehousing using the factory hardware. All hardware should be installed from the outside. Snug, but do not fully tighten at this time.
- Repeat this procedure on the passenger side. All radius arm hardware will be tightened once the vehicle is on the ground.

## 5) COMPRESSION TRAVEL STOP EXTENSIONS...

- Pry the front compression travel stops out of their mounting cups, then unbolt the cups from the frame.
- On each side, position a compression travel stop extension (#55-01-9024 driver side and #55-02-9024 passenger side) on the frame in the location that the stop cup was just removed and secure it to the frame using the supplied 3/8" x 1-1/4" bolt and nyloc nut. Tighten (23).
- Drill out the mounting hole in the factory compression stop cup to 3/8", then attach the cup to the "01" and "02" brackets using the supplied 3/8" x 1" bolt, washer, and nyloc nut. Tighten (23).
- Press the factory compression stops back into their mounting cups.

## 6) COIL SPRINGS...

- Lower the front axle enough to facilitate installing the new coils springs. Position the coil springs (01-294 for trucks with diesel engines and #01-295 or vehicles with gas engines) in the lower coil buckets on the axle and rotate as necessary to be sure that the pigtail of the coil is indexed properly in the bucket. Position the factory rubber isolator on top of each coil, then raise the axle enough to seat the coil springs in the upper spring buckets.

## 7) SHOCK ABSORBERS...

- Install the bushings, sleeves, and boots on the front shock absorbers.
- Compress the front springs enough to install the front shocks. Secure the lower (body) end of the shock to the axle using the factory hardware and the upper (rod) end using the factory

bushing taken from the original shocks. Tighten the lower end (136), then tighten the stem end until the bushings swell slightly.

### 8) BRAKE HOSE EXTENSIONS...

- Factory brackets secure the brake hoses to the front of the coil tower on the frame; these brackets were unbolted from the coil towers during initial disassembly. Attach the brake line drop brackets (#55-07-9024) to the coil towers where the factory brackets were once mounted using the factory hardware (76 in-lb).
- Insert the supplied 5/16" x 3/4" bolt through the bracket and coil tower just below the factory bolt and secure using the supplied 5/16" nyloc nut (13).
- Carefully reform the metal brake line as necessary in order to line up the factory brake hose bracket with the lower end of the "07" bracket. Attach the factory bracket to the "07" bracket using the supplied 1/4" x 3/4" bolt and nyloc nut (76 in-lb).
- Re-attach the lower brake hose brackets to the axle using the factory hardware and tighten (9).

### 9) STEERING STABILIZER DROP BRACKET...

- The factory steering stabilizer bracket is attached to the front lip of the engine crossmember (towards the passenger side) via a two-bolt tab. Remove the nuts securing the stabilizer mount to the crossmember. It is not necessary to entirely remove the factory bracket.
- Position the steering stabilizer drop bracket (#55-03-9024) on the back side of the crossmember lip and secure it using the factory tab bolts and nuts (the crossmember lip should be "sandwiched" between the "03 bracket and the factory stabilizer bracket). Do not tighten at this time.
- Install the supplied 5/8" x 1-1/2" bolt through the factory bracket (where the stabilizer used to mount) and the "03" bracket. The bolt should be installed from the outside and secured with the supplied 5/8" washer and nyloc nut.
- Tighten the 5/8" bolt (112) and factory bolts (136).
- Install a factory washer and supplied bushing half on the stem end of the stabilizer, then position the stem through the remaining hole in the "03" stabilizer drop bracket. Install the remaining bushing half, washer, and factory nut, then tighten until the bushings swell slightly.

### 10) FINAL ASSEMBLY...

- Secure the ABS wires to the radius arms using the factory retaining clips.
- Reattach the drag link to the pitman arm using the factory castellated nut and the supplied new cotter pin (67).

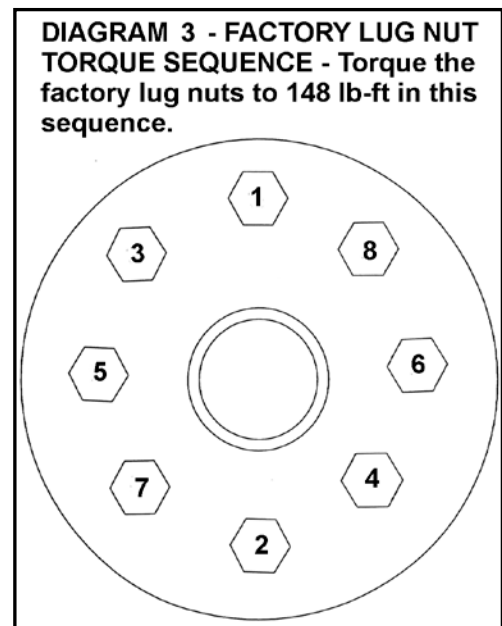

## 11) TIRES / WHEELS...

- [DIAGRAM 3] Tighten the lug nuts (148) in the sequence shown.

**WARNING:** When the tires / wheels are installed, always check for and remove any corrosion, dirt, or foreign material on the wheel mounting surface, or anything that contacts the wheel mounting surface (hub, rotor, etc.). Installing wheels without the proper metal-to-metal contact at the wheel mounting surfaces can cause the lug nuts to loosen and the wheel to come off while the vehicle is in motion.

**WARNING:** Retighten lug nuts at 500 miles after any wheel change, or anytime the lug nuts are loosened. Failure to do so could cause wheels to come off while vehicle is in motion.

- Lower the vehicle to the floor.

## 12) HARDWARE TIGHTENING SEQUENCE...

- Tighten the following hardware:

- 18mm radius arm hardware (230)
- factory hardware at rear of radius arm (222)

## 13) TRACK BAR...

- Line up the track bar with the slotted hole of the new track bar bracket.
- Observe the two supplied track bar keys and note that the hole in each key is offset to one side. **Position the keys so that the holes are offset to the passenger side** and insert them into the slotted holes of the track bar bracket. Insert the factory track bar bolt through the bracket, keys, and track bar and secure using the factory hardware. Tighten (406).

**IMPORTANT:** Yes, the proper torque specification for the track bar eye bolt is 406 lb-ft; this is not a typographical error. If the appropriate torque wrench is not available, tighten the bolt as much as possible, then take the vehicle to the Ford Dealer or a heavy equipment repair shop to perform the final torque operation. Proper torque on this bolt is critical.

## 14) ANTI-SWAY BAR LINK EXTENSIONS...

- Thread the female end of the anti-sway bar link extensions (44-04-9024) on to the factory sway bar end links and tighten (57).
- Attach the "04" sway bar link extensions to the axlehousing using the factory bushings and hardware. Tighten until the bushings swell slightly.

## 15) CLEARANCE CHECK...

- Raise the vehicle and place a jack stand under each frame rail just behind the radius arm attaching points. With the suspension "hanging" at full extension travel, cycle steering lock-to-lock and check all components for proper operation and clearances. Pay special attention to the clearance between the tires / wheels and brake hoses, wiring, etc.
- Lower vehicle to the floor.

## 16) FINAL CLEARANCE and TORQUE CHECK...

- With vehicle on floor, cycle steering lock-to-lock and inspect the tires / wheels, and the steering, suspension, and brake systems for proper operation, tightness, and adequate clearance.

## 17) REAR LIFT...

**NOTE:** Rear lift is sold separately and includes separate instructions. In addition to what is detailed in that instruction form, perform the following:

- Verify the vehicle is in Park or Low gear with the parking brake set. Remove and discard the rear shock absorbers.
- Install the bushings, sleeves, and boots on the new rear shocks.
- Install the shocks in the factory location using the factory hardware. In some instances it will be necessary to position a 1/2" SAE washer between the shock bushing and lower mount. If necessary the washers are supplied with the shock hardware. All shocks except those equipped with a remote reservoir must be installed with the rod end up. Tighten the upper (85) and lower (85) hardware.

## 18) Activate four wheel drive system and check front hubs for engagement

## 19) HEADLIGHTS...

- Readjust headlights to proper setting.

## 20) SUPERLIFT WARNING DECAL...

- Install the WARNING TO DRIVER decal on the inside of the windshield, or on the dash, within driver's view. Refer to the "NOTICE TO DEALER AND VEHICLE OWNER" section below.

## 21) ALIGNMENT...

Realign vehicle to factory specifications. Alignment must be performed by a qualified professional.

## Limited Lifetime Warranty / Warnings

Your Superlift® product is covered by the Limited Warranty explained below that gives you specific legal rights. This limited warranty is the only warranty Superlift® makes in connection with your product purchase. Superlift® neither assumes nor authorizes any retailer or other person or entity to assume for it any other obligation or liability in connection with this product or limited warranty.

**What is covered?** Subject to the terms below, Superlift® will repair or replace its products found defective in materials or workmanship for so long as the original purchaser owns the vehicle on which the product was originally installed. Your warrantor is LKI Enterprises, Inc. d/b/a Superlift® Suspension Systems ("Superlift®").

**What is not covered?** Your Superlift® Limited Warranty does not cover products, parts or vehicles Superlift® determines to have been damaged by or subjected to:

- Alteration, modification or failure to maintain.
- Normal wear and tear (bushings, tie-rod ends, etc.). Scratches or defects in product finishes (powdercoating, plating, etc.),
- Damage to or resulting from vehicle's electronic stability system, related components or other vehicle systems.

- Racing or other vehicle competitions or contests. Accidents, impact by rocks, trees, obstacles or other aspects of the environment.
- Theft, vandalism or other intentional damage.

**Remedy Limited to Repair / Replacement.** The exclusive remedy provided hereunder shall, upon Superlift's inspection and at Superlift's option, be either repair or replacement of product or parts covered under this Limited Warranty. Customers requesting warranty consideration should contact Superlift® by phone to obtain a Returned Goods Authorization number. All removal, shipping and installation costs are customer's responsibility.

If a replacement part is needed before the Superlift® part in question can be returned, you must first purchase the replacement part. Then, if the part in question is deemed warrantable, you will be credited / refunded.

#### **Other Limitations - Exclusion of Damages - Your Rights Under State Law**

- Neither Superlift® nor your independent Superlift® dealer are responsible for any time loss, rental costs, or for any incidental, consequential or other damages you may have.
- This Limited Warranty gives you specific rights. You may also have other rights that vary from state to state. For example, while all implied warranties are disclaimed herein, any implied warranty required by law is limited to the terms of our Limited Lifetime Warranty as described above. Some states do not allow limitations of how long an implied warranty lasts and / or do not allow the exclusion or limitation of incidental or consequential damages, so the limitations and exclusions herein may not apply to you.

#### **Important Product Use and Safety Information / Warnings**

As a general rule, the taller a vehicle is, the easier it will roll over. Offset, as much as possible, what is lost in rollover resistance by increasing tire track width. In other words, go "wide" as you go "tall". Many sportsmen remove their mud tires after hunting season and install ones more appropriate for street driving; always use as wide a tire and wheel combination as feasible to enhance vehicle stability. We strongly recommend, because of rollover possibility, that the vehicle be equipped with a functional roll bar and cage system. Seat belts and shoulder harnesses should be worn at all times. Avoid situations where a side rollover may occur.

Generally, braking performance and capabilities are decreased when significantly larger / heavier tires and wheels are used. Take this into consideration while driving. Also, changing axle gear ratios or using tires that are taller or shorter than factory height will cause an erroneous speedometer reading. On vehicles equipped with an electronic speedometer, the speed signal impacts other important functions as well. Speedometer recalibration for both mechanical and electronic types is highly recommended.

Do not add, alter, or fabricate any factory or aftermarket parts to increase vehicle height over the intended height of the Superlift product purchased. Mixing component brands is not recommended.