



SUPERLIFT[®]

S U S P E N S I O N

Superlift[®] 4" standard lift system for 2011 and Newer FORD F-250 / F-350 SUPER DUTY 4WD INSTALLATION INSTRUCTIONS

INTRODUCTION

Installation requires a professional mechanic. Prior to beginning, inspect the vehicles steering, driveline, and brake systems, paying close attention to the suspension link arms and bushings, anti-sway bars and bushings, tie rod ends, pitman arm, ball joints and wheel bearings. Also check the steering sector-to-frame and all suspension-to-frame attaching points for stress cracks. The overall vehicle must be in excellent working condition; repair or replace all worn parts.

Read instructions several times before starting. Be sure you have all needed parts and know where they install. Read each step completely as you go.

NOTES:

- Front end realignment is necessary.
- An arrow on diagrams indicates which direction is toward the front of the vehicle.
- A foot-pound torque reading is given in parenthesis () after each appropriate fastener.
- Do not fabricate any components to gain additional suspension height.
- Prior to drilling or cutting, check behind the surface being worked on for any wires, lines, or hoses that could be damaged.
- After drilling, file smooth any burrs and sharp edges.
- Prior to operating a torch or saw, protect any heat-sensitive components located in the immediate area by covering them with a water-saturated cloth. Most undercoating are flammable but can be extinguished using a water-filled spray bottle. Have a spray bottle and an ABC rated fire extinguisher on hand.
- Paint or undercoat all exposed metal surfaces.
- Prior to attaching components, be sure all mating surfaces are free of grit, grease, undercoating, etc.
- A factory service manual should be on hand for reference.
- Use the check-off box "☐" found at each step to help you keep your place. Two "☐☐" denotes that one check-off box is for the driver side and one is for the passenger side. Unless otherwise noted, always start with the driver side.

PARTS LIST ... The part number is stamped into each part or printed on an adhesive label. Identify each part and place the appropriate mounting hardware with it.

PART NO	DESCRIPTION (Qty.- if more than one)	NEW ATTACHING (Qty.- if more than one)	BAG #
01-294	(2) front coil spring, diesel		
OR			
01-295.....	(2) front coil spring, gas		
66-07-9064	(2) compression stop	(2) 3/8" x 5-1/2" bolt (4) 3/8" SAE washer (2) 3/8" nyloc nut	77-9064-2
	extension, front		
55-01-9064.....	(1) radius arm drop bracket	(2) 18mm x 130mm bolt (4) 18mm washer (2) 18mm nyloc nut (2) 1-1/8" OD x 2-3/4" sleeve (1) 1/2" x 1-1/4" bolt (1) 1/2" nyloc nut	77-9064-2
55-02-9064.....	(1) radius arm drop bracket	(2) 18mm x 130mm bolt (4) 18mm washer (2) 18mm nyloc nut (2) 1-1/8" OD x 2-3/4" sleeve (1) 1/2" x 1-1/4" bolt (1) 1/2" nyloc nut	77-9064-2
55-01-9062.....	front track bar bracket		
55-01-9074.....	track bar bracket spacer		
55-04-9066.....	steering stabilizer bracket.....	(2) 1/2" x 1-1/4" bolt (2) 1/2" SAE washer (2) 1/2" Stover nut (1) 12mm nut (1) 12mm washer	77-9074
55-05-9024.....	(2) track bar key		77-9064-2
55-03-9074.....	(2) front sway bar drop brackets..	(4) 7/16" x 1-1/2" bolt..... (8) 7/16" SAE washer (4) 7/16" nyloc nut	77-9074
55-09-9074.....	rear brake line bracket.....	(1) 7/16" x 1" bolt (2) 7/16" SAE washer (1) 7/16" nyloc nut	
	(2) shock absorber, front	(2) hardware pack and cable tie	
	(2) shock absorber, rear	(2) hardware pack and cable tie	
00461	decals, "Warning To Driver"		

INSTALLATION PROCEDURE

1) PREPARE VEHICLE...

- Prior to raising the vehicle, disconnect the track bar from its attachment point on the frame and let the bar hang. Save all hardware for re-use.
- Disconnect the anti-sway bar links from their attachment points on the sway bar and the front axle. Discard the links but save all hardware for re-use.
- Place vehicle in neutral. Raise front of vehicle with a jack and secure a jack stand beneath each frame rail, behind the radius arm mounts. Ease the frame down onto the stands, place transmission in low gear or "park", and chock rear tires. Remove front tires.

2) CONTINUE DISASSEMBLY...

- Position a jack so that it supports, but does not raise, the front axle.
- Remove and discard the front shock absorbers.
- Unbolt the stem end of the front steering stabilizer from the frame mount. Save all hardware for re-use.
- Unbolt the factory steering stabilizer from the factory mount. Save all hardware for re-use.
- Unbolt the factory sway bar bracket from the frame. Save all hardware for re-use.
- Remove the cotter pin and castellated nut from the drag link where it attaches to the pitman arm. Using the appropriate puller tool, separate the drag link from the pitman arm.
- Unbolt the bracket securing the front brake hose to the frame. Save all hardware for re-use.
- Unbolt the lower brake hose bracket securing the hose to the axle. Save all hardware for re-use.
- Carefully lower the front axle enough to facilitate the removal of the front coil springs. Save the rubber isolators at the top of the coils for re-use.
- Unbolt the factory track bar bracket from the frame. Save all hardware for re-use.

3) TRACK BAR BRACKET...

NOTE: Inspect the area of the frame crossmember where the track bar bracket attaches. Often there is an excessive amount of undercoating build-up on the crossmember, especially on the back (rearward facing) portion of the crossmember where the undercoating has pooled up. Scrape off any excessive undercoating to prevent the track bar bracket from loosening over time.

- ❑ [DIAGRAM 1] Position the Superlift® track bar spacer (#55-01-9074) between the track bar bracket (#55-01-9062) and the frame over the rear hole, then position bracket on the frame in the same place as the original and secure using the factory hardware. There are a total of five bolts; three attached to a retaining tab plus two additional bolts. Once all the bolts are started, tighten (136).

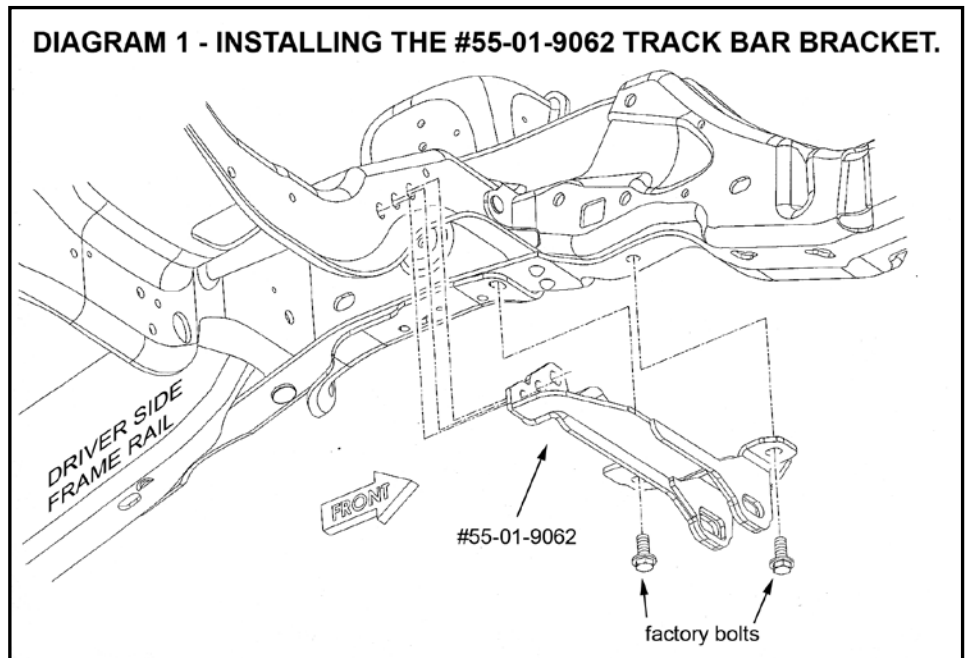

4) **RADIUS ARMS...**

NOTE: Perform the following steps one side at a time. Start on the driver side.

IMPORTANT: The radius arms have two mounting ears that attach to the axle; one is equipped with a round hole and the other is slotted. The slotted ear of each radius arm is supposed to be attached to the lower axle mount. However, it has been noted that one or both of the radius arms on some trucks are installed with the slotted ear attached to the top mount. It is suspected that this was an assembly line error. Regardless of how the radius arms were attached to the truck during disassembly, they need to be installed with the slotted hole attached to the lower axle mount.

- ❑❑ Unclip the ABS wire from the radius arm and secure it out of the way.
- ❑❑ Verify once again that the axle is supported by the jack, then unbolt the radius arm from the frame and front axle. Save all hardware for re-use.

- ❑❑ [DIAGRAM 2] Position the radius arm drop bracket (#55-01-9064 driver side and #55-02-9064 passenger side) inside the factory mount on the frame as shown. Line up the side and rear mounting holes present in the drop bracket with the

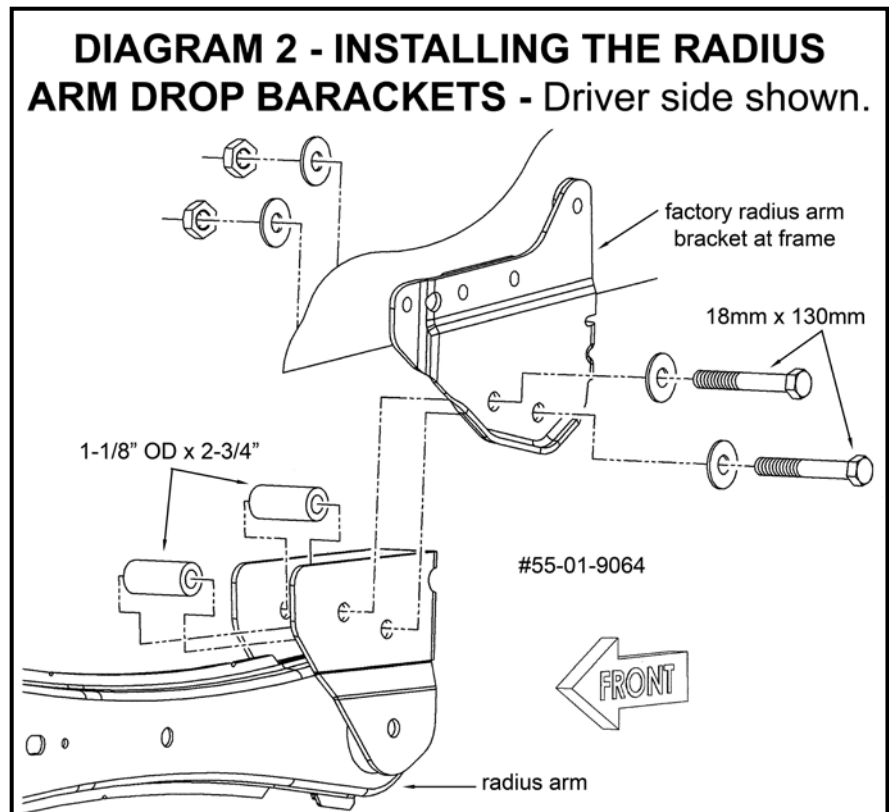

existing holes in the factory mount.

- ❑❑ With the drop bracket in position, install the supplied 1/2" x 1-1/4" bolt and nyloc nut in the rear hole. The bolt should be installed from the front. Do not tighten at this time.
- ❑❑ Position the supplied 1-1/8" OD x 2-3/4" sleeves inside the drop bracket as shown in Diagram 2, and line them up with the two mounting holes. Install the supplied 18mm x 130mm bolts with washers through the factory mount, drop bracket, and sleeves. The bolts should be installed from the outside and secured with the remaining washers and stover nuts.

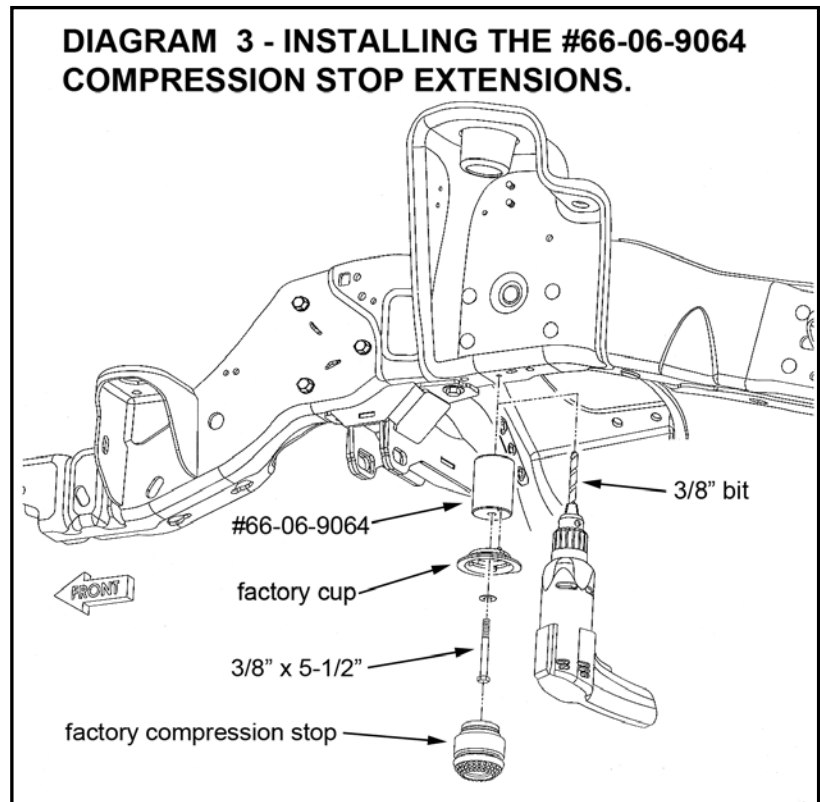

- ❑❑ Tighten the 1/2" bolt (57) followed by the 18mm bolts (200).
- ❑❑ Attach the radius arm to the drop bracket and axle housing using the factory hardware. All hardware should be installed from the outside. Snug, but do not fully tighten at this time.
- ❑ Repeat this procedure on the passenger side. All radius arm hardware will be tightened once the vehicle is on the ground.

5) COMPRESSION TRAVEL STOP EXTENSIONS...

- ❑❑ Pry the front compression travel stops out of their mounting cups, then unbolt the cups from the frame.
- ❑❑ On each side, drill out the factory compression stop cup mounting hole in the bottom of the frame to 3/8". Also drill out the hole in the factory cups to 3/8".
- ❑❑ [DIAGRAM 3] Position a compression stop cup on a compression stop extension (#66-07-9064). Note there is an alignment tab present on the factory cup; place this tab in the secondary hole in the "02" extension so that the cup will sit flat on the extension. Slide the supplied 3/8" x 5-1/2" bolt with an SAE washer through the cup and extension.
- ❑❑ Position the compression stop assembly on the bottom of the frame and insert the 3/8" x 5-1/2" bolt through the 3/8" hole drilled earlier. Secure using the supplied 3/8" SAE washer and nyloc nut.
- ❑❑ Rotate the compression stop cups so that the flat edge of the cup is positioned toward the inside of the vehicle as shown in Diagram 3, then tighten the 3/8" bolt (23).
- ❑❑ Press the factory compression stops into the mounting cups.

6) COIL SPRINGS...

- Lower the front axle enough to facilitate installing the new coils springs. Position the coil springs (01-294 for trucks with diesel engines and #01-295 or vehicles with gas engines) in the lower coil buckets on the axle and rotate as necessary to be sure that the pigtail of the coil is indexed properly in the bucket. Position the factory rubber isolator on top of each coil, then raise the axle enough to seat the coil springs in the upper spring buckets.

7) SHOCK ABSORBERS...

- Install the bushings, sleeves, and boots on the front shock absorbers.
- Compress the front springs enough to install the front shocks. Secure the lower (body) end of the shock to the axle using the factory hardware and the upper (rod) end using the supplied bushing washer and nut. Tighten the lower end (136), then tighten the stem end until the bushings swell slightly.

8) BRAKE HOSES...

NOTE: Perform these steps one side at a time. Start on the passenger side.

- [DIAGRAM 4] Factory brackets secure the brake hoses to the frame; these brackets were unbolted from the frame during disassembly. Completely remove the frame-mounting bracket from the brake hose by removing the horseshoe clip. Gently loosen the fitting between the hard line and the rubber hose just enough to rotate the hose so that it is pointing downward.

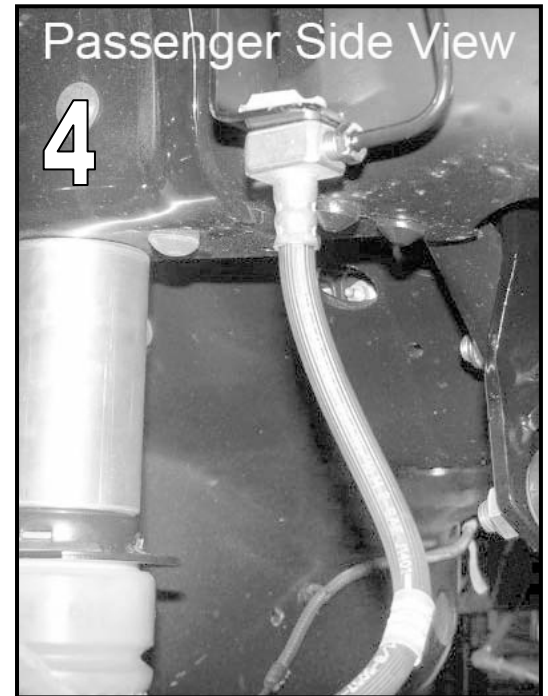

- The factory brackets must be swapped from side to side. Re-attach the driver side bracket on the passenger side hose and fasten in the factor location using the factory hardware. Repeat this step on the driver's side using the passenger side bracket.

- Re-attach the lower brake hose brackets to the axle using the factory hardware and tighten (9).

9) STEERING STABILIZER... [DIAGRAM 5]

- Position the steering stabilizer bracket to the track bar crossmember and fasten with the supplied 1/2" hardware. Attach the stabilizer to the steering stabilizer bracket (#55-04-9066) and tighten until bushings swell slightly.



10) TIRES / WHEELS...

- ❑ [DIAGRAM 6] Tighten the lug nuts (148) in the sequence shown.

WARNING: When the tires / wheels are installed, always check for and remove any corrosion, dirt, or foreign material on the wheel mounting surface, or anything that contacts the wheel mounting surface (hub, rotor, etc.). Installing wheels without the proper metal-to-metal contact at the wheel mounting surfaces can cause the lug nuts to loosen and the wheel to come off while the vehicle is in motion.

WARNING: Retighten lug nuts at 500 miles after any wheel change, or anytime the lug nuts are loosened. Failure to do so could cause wheels to come off while vehicle is in motion.

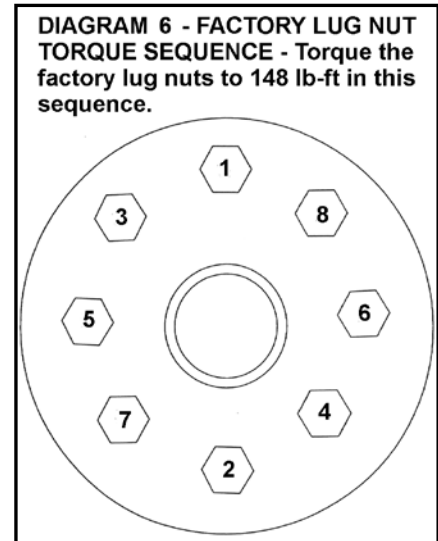

- ❑ Lower the vehicle to the floor.

11) HARDWARE TIGHTENING SEQUENCE...

- ❑ Tighten the following hardware:
 - ❑❑ 18mm radius arm hardware (230)
 - ❑❑ factory hardware at rear of radius arm (222)

12) TRACK BAR...

- ❑ Line up the track bar with the slotted hole of the new track bar bracket.
- ❑ Observe the two supplied track bar keys and note that the hole in each key is offset to one side. **Position the keys so that the holes are offset to the passenger side** and insert them into the slotted holes of the track bar bracket. Insert the factory track bar bolt through the bracket, keys, and track bar and secure using the factory hardware. Tighten (406).

IMPORTANT: Yes, the proper torque specification for the track bar eye bolt is 406 lb-ft; this is not a typographical error. If the appropriate torque wrench is not available, tighten the bolt as much as possible, then take the vehicle to the Ford Dealer or a heavy equipment repair shop to perform the final torque operation. Proper torque on this bolt is critical.



13) ANTI-SWAY BAR DROP BRACKETS...[DIAGRAM 7]

- Install the new drop brackets (#55-03-9074) on the frame using the factory hardware. The open part of the “C” should face the outside of the vehicle on the passenger side and the inside on the driver’s side. Attach the factory bracket to the new drop bracket using the supplied 7/16” x 1-1/2” hardware.

14) CLEARANCE CHECK...

- Raise the vehicle and place a jack stand under each frame rail just behind the radius arm attaching points. With the suspension “hanging” at full extension travel, cycle steering lock-to-lock and check all components for proper operation and clearances. Pay special attention to the clearance between the tires / wheels and brake hoses, wiring, etc.

- Lower vehicle to the floor.

15) FINAL CLEARANCE and TORQUE CHECK...

- With vehicle on floor, cycle steering lock-to-lock and inspect the tires / wheels, and the steering, suspension, and brake systems for proper operation, tightness, and adequate clearance.

16) REAR LIFT...

- Verify the vehicle is in Park or Low gear with the parking brake set. Remove and discard the rear shock absorbers.

- Install the bushings, sleeves, and boots on the new rear shocks.

17) REAR BRAKE LINE BRACKET... [DIAGRAM 8]

- Unclip the rear axle vent hose from the top frame lip and re-clip to the bottom frame lip. Remove the rear axle vent hose from the barbed fitting. Remove the barbed fitting. Position the rear brake line bracket (#55-09-9074) under the factory bracket and attach it using the factory barbed fitting. Attach the factory bracket to the Superlift bracket using the supplied 7/16” hardware.

18) LIFT BLOCKS...

- Support the rear axle housing with a jack. Remove the U-bolts from one side of the axle, then loosen (but do not remove) the U-bolts on the other side.

- Lower the axle on the side with the U-bolts removed enough to facilitate installing the lift block. Note the block has a taper in it; the tall end of the taper goes toward the rear of the vehicle. Be sure the bottom of the spring and the top of the spring perch are clean and free

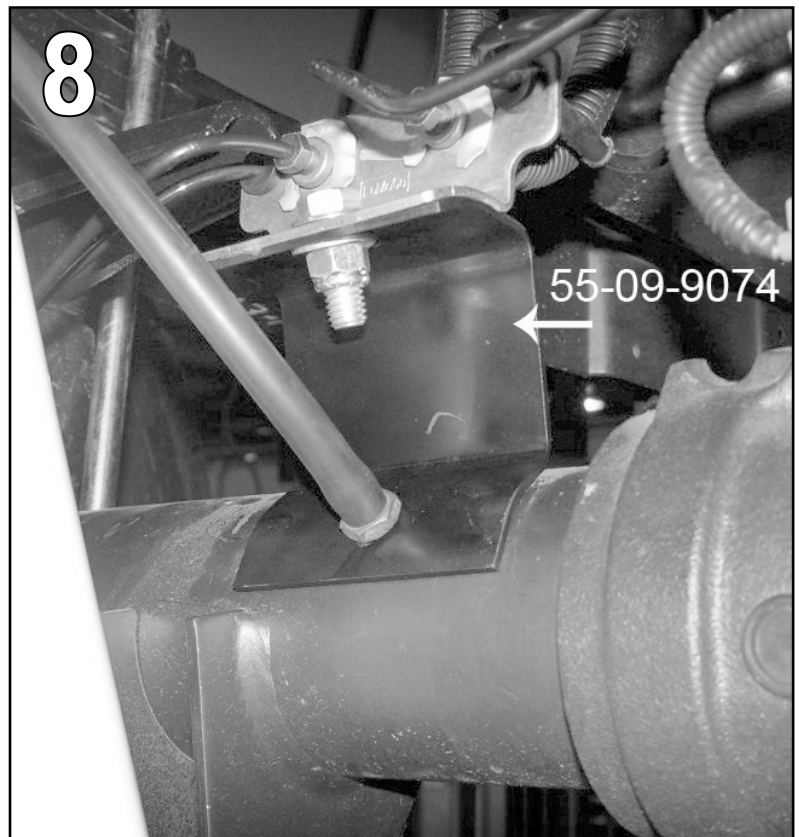

of debris, then seat the pin in the block in the spring perch. Line up the center pin of the spring with the hole in the block, then raise the axle enough to seat the block.

- Install the U-bolts and just snug them for now using an “X” pattern. Remove the U-bolts from the other end of the axle and then install the blocks and supplied U-bolts.
- Tighten the U-bolts in an “X” pattern (185).

19) SHOCK ABSORBERS...

- Install the shocks in the factory location using the factory hardware. In some instances it will be necessary to position a 1/2” SAE washer between the shock bushing and lower mount. If needed, the washers are supplied with the shock hardware. All shocks must be installed with the rod end up. Tighten the upper (85) and lower (85) hardware.

20) Activate four wheel drive system and check front hubs for engagement

21) HEADLIGHTS...

- Readjust headlights to proper setting.

22) SUPERLIFT® WARNING DECAL...

- Install the WARNING TO DRIVER decal on the inside of the windshield, or on the dash, within driver’s view. Refer to the “IMPORTANT PRODUCT USE AND SAFETY INFORMATION / WARNINGS” text found at the end of this instruction sheet.

23) ALIGNMENT...

Realign vehicle to factory specifications. Alignment must be performed by a qualified professional.

Limited Lifetime Warranty / Warnings

Your Superlift® product is covered by the Limited Warranty explained below that gives you specific legal rights. This limited warranty is the only warranty Superlift® makes in connection with your product purchase. Superlift® neither assumes nor authorizes any retailer or other person or entity to assume for it any other obligation or liability in connection with this product or limited warranty.

What is covered? Subject to the terms below, Superlift® will repair or replace its products found defective in materials or workmanship for so long as the original purchaser owns the vehicle on which the product was originally installed. Your warrantor is LKI Enterprises, Inc. d/b/a Superlift® Suspension Systems (“Superlift®”).

What is not covered? Your Superlift® Limited Warranty does not cover products, parts or vehicles Superlift® determines to have been damaged by or subjected to:

- Alteration, modification or failure to maintain.
- Normal wear and tear (bushings, tie-rod ends, etc.). Scratches or defects in product finishes (powder coating, plating, etc.),
- Damage to or resulting from vehicle’s electronic stability system, related components or other vehicle systems.
- Racing or other vehicle competitions or contests. Accidents, impact by rocks, trees, obstacles or other aspects of the environment.
- Theft, vandalism or other intentional damage.

Remedy Limited to Repair / Replacement. The exclusive remedy provided hereunder shall, upon Superlift's inspection and at Superlift's option, be either repair or replacement of product or parts covered under this Limited Warranty. Customers requesting warranty consideration should contact Superlift® by phone to obtain a Returned Goods Authorization number. All removal, shipping and installation costs are customer's responsibility.

If a replacement part is needed before the Superlift® part in question can be returned, you must first purchase the replacement part. Then, if the part in question is deemed warrantable, you will be credited / refunded.

Other Limitations - Exclusion of Damages - Your Rights Under State Law

- Neither Superlift® nor your independent Superlift® dealer are responsible for any time loss, rental costs, or for any incidental, consequential or other damages you may have.
- This Limited Warranty gives you specific rights. You may also have other rights that vary from state to state. For example, while all implied warranties are disclaimed herein, any implied warranty required by law is limited to the terms of our Limited Lifetime Warranty as described above. Some states do not allow limitations of how long an implied warranty lasts and / or do not allow the exclusion or limitation of incidental or consequential damages, so the limitations and exclusions herein may not apply to you.

Important Product Use and Safety Information / Warnings

As a general rule, the taller a vehicle is, the easier it will roll over. Offset, as much as possible, what is lost in rollover resistance by increasing tire track width. In other words, go "wide" as you go "tall". Many sportsmen remove their mud tires after hunting season and install ones more appropriate for street driving; always use as wide a tire and wheel combination as feasible to enhance vehicle stability. We strongly recommend, because of rollover possibility, that the vehicle be equipped with a functional roll bar and cage system. Seat belts and shoulder harnesses should be worn at all times. Avoid situations where a side rollover may occur.

Generally, braking performance and capabilities are decreased when significantly larger / heavier tires and wheels are used. Take this into consideration while driving. Also, changing axle gear ratios or using tires that are taller or shorter than factory height will cause an erroneous speedometer reading. On vehicles equipped with an electronic speedometer, the speed signal impacts other important functions as well. Speedometer recalibration for both mechanical and electronic types is highly recommended.

Do not add, alter, or fabricate any factory or aftermarket parts to increase vehicle height over the intended height of the Superlift product purchased. Mixing component brands is not recommended.

All Superlift® material is copyrighted. All images found in our installation instructions, our catalog and in any Superlift® marketing forums are the sole property of or licensed to Superlift®. Any reproduction of said materials, in part or in whole, without the express written permission of Superlift® is strictly forbidden. Superlift®, Level-It™, Rockrunner™, Swamprunner™, Superide™, Superide SS™ and SSR™, Black Diamond®, XCL™, X2™ Super Trac™, Torque Max™, Torque Max SS™, eXtreme Ring™, Rail Wrap™, Bullet Proof Brake Hose™, TruSpeed™, Frame Integrated Technology™, F.I.T. Series™ and Rock Fink™ are registered trademarks of Superlift® Suspension Systems. Superlift® Suspension Systems is a Division of Bret Lovett's Lift Kits Incorporated.