

# SumoSprings Rear

Ford F53 Motor Home 20K-22K GVWR (1990-2004)

REAR

Part #SSR-181-54-1

Drivers Side (Passenger Side Similar)

## Parts List

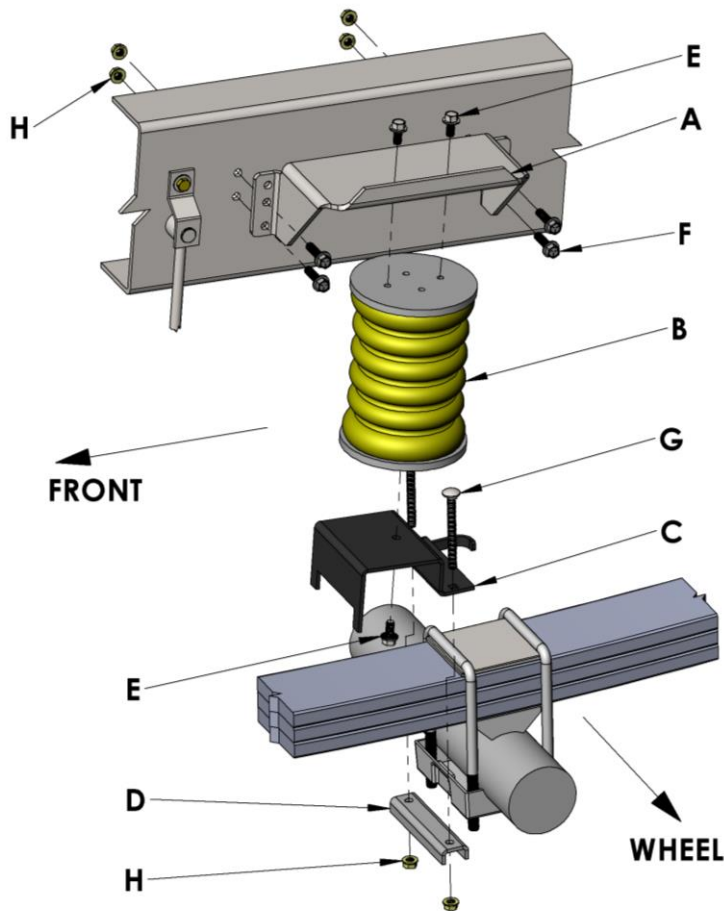

Diagram A

Item	Part #	Description	Quant.
A	512046	Upper Frame bracket	2
B	511403	SumoSpring	2
C	512108	Lower bracket	2
D	512042	U- bracket strap	2
E	512207	3/8-16 x 3/4" serrated flange hex bolt	6
F	512301	3/8-16x 1.5" serrated flange bolt	8
G	512247	3/8-16 x 4" carriage bolts	4
H	512302	3/8-16 top lock flange nut	12

## Tool List

Floor Jack	1
Jack stands	2
Wheel blocks	4
9/16" wrench	2
Drill	1
7/16" Drill bit	1

### NOTE HOLES IN FRAME:

1. UPPER TO BE DRILLED 7/16"
2. LOWER ARE EXISTING

## **Installation Instructions\***

- 1) Park vehicle on level hard surface. Engage emergency brake. Place blocks in front and behind front wheels to prevent rolling. Observe all safety precautions and wear safety glasses.
- 2) Raise rear of vehicle allowing the axle to hang freely. Support the frame using safety jack stands.
- 3) Attach Upper Frame bracket (Item A) to the top of the SumoSpring (Item B) using two 3/8-16x3/4" serrated flange hex bolts (Item E). Attach the Lower bracket (Item C) to the bottom of the SumSpring using one 3/8-16x3/4" serrated flange hex bolt (Item E) as in Diagram A above.
- 4) Insert two 3/8-16 x 4" carriage bolts (Item G) into the two square openings in the lower bracket (Item C) in such a way that they straddle the factory spring-pack. Position the lower bracket so that the shorter end down-stand fingers capture the factory u-bolt (see Diagram B below).
- 5) Secure the lower bracket (Item C) to the factory spring-pack using the u-bracket strap (Item D) the two carriage bolts (Item G) two 5/16" washers (Item H) and two 3/8-16 Top-lock nuts (Item I).



**Diagram B**

- 6) Repeat steps three through five on the opposite side of the vehicle.
- 7) Jack up axle until Upper Frame Bracket (Item A) is in correct position on frame with the two bottom holes aligned with the existing 5/8" holes in the frame as shown in Diagram C below. Mark and drill two upper holes using a 7/16" drill bit (ensure clearance on all cables/service lines inside the frame prior to drilling).

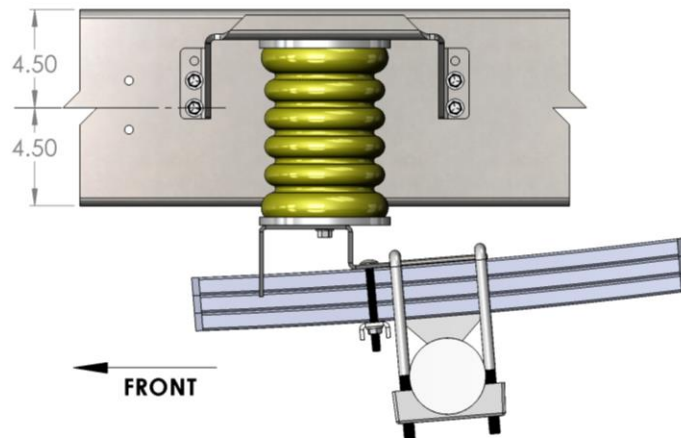

**Diagram C**

- 8) Repeat step seven on opposite side.
- 9) Carefully lower vehicle to the hard surface. Remove the blocks in front and back of the rear wheels.
- 10) Release emergency brake.
- 11) Fill out warranty card and send to SuperSprings.

**\*Contact factory if installation brackets create conflict with coach plumbing/electrical hardware.**

**Important Notice.**

- 1) For easy installation please read instructions completely first and have all necessary tools available.
- 2) We recommend that this installation be done by a professional or persons with sound mechanical knowledge.
- 3) SumoSprings are designed to work with the original factory [springs](#) only.
- 4) These instructions are meant as a guide for the installation of SumoSprings. SuperSprings International assumes no liability for the actual installation process. Installers should apply common automotive safety practices when raising, lowering and working on vehicles.
- 5) SumoSprings are designed to enhance the vehicles load carrying performance and road handling however it does not authorize (or recommend) loading beyond the manufacturer's GVWR specifications.

***To prevent damage to the vehicle and to ensure safety, do not exceed the maximum load recommended by the vehicles manufacturer (GVWR).***

# **SumoSprings** **Rear**

Suspension Enhancement

**Ford F-53 Chassis Motor Home 20K-22K GVWR [1990 ~ 2004]**

**SumoSprings Part# SSR-181-54-1**



**Installed**

**SSR-181-54-1**

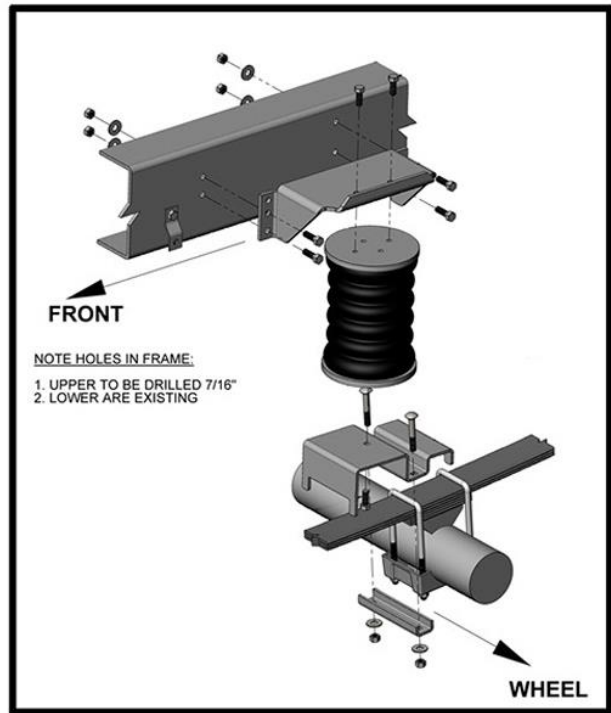

**Installation**