

SumoSprings Rear

Workhorse W20/22/24 Motor Home (2001-2010)

REAR

Part #SSR-280-54-1

Drivers Side (Passenger Side Similar)

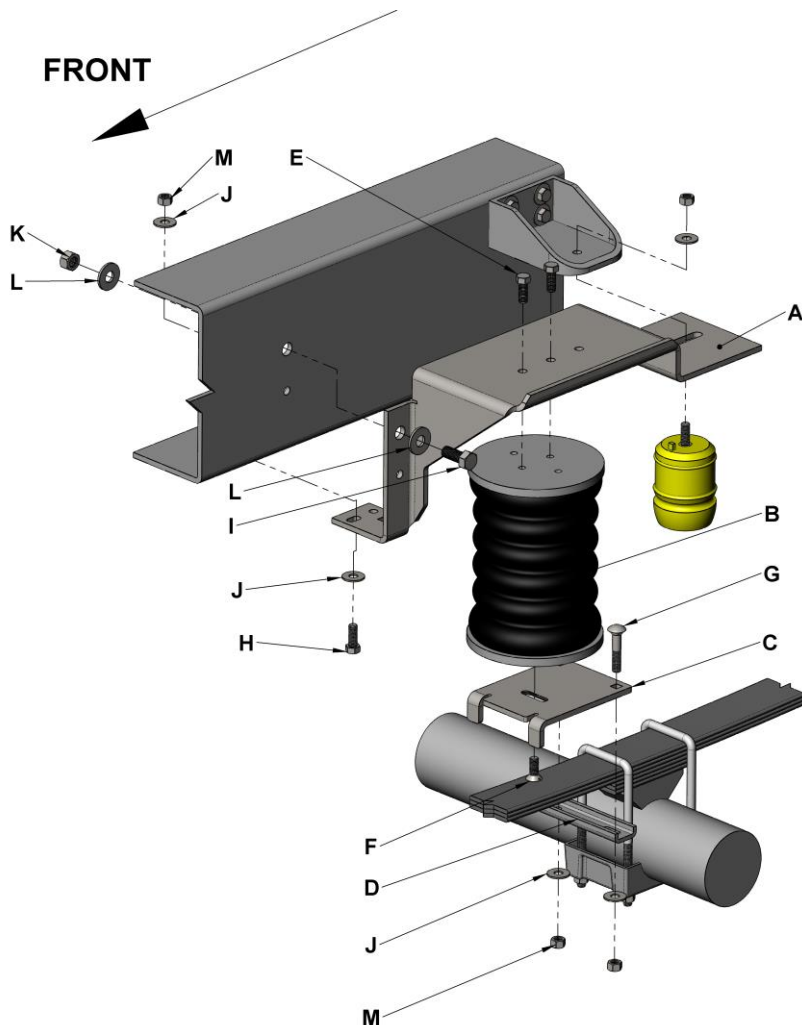

Item	Part #	Description	Quant.
A	512044	Upper bracket DS	1
	512041	Upper bracket PS	1
B	511401	SumoSpring	2
C	512040	Lower bracket	2
D	512047	U- bracket strap	2
E	512207	3/8-16 x 3/4" serrated flange hex bolt	4
F	512245	3/8-16x 7/8" FHCS (cap screws)	2
G	512247	3/8-16 x 4" carriage bolts	4
H	512252	3/8-16 x 1 3/4" hex bolt	2
I	512253	1/2-16 x 1 1/2" hex bolt	2
J	512227	3/8" USS flat washers steel	8
K	112164	1/2" Top-lock nut	2
L	112130	1/2" steel washer	4
M	512234	3/8-16 Top-lock nut	6

Floor Jack	1
Jack stands	2
Wheel blocks	4
9/16" wrench	2
3/4" wrench	2
Drill and 3/8 drill bit	1

Installation Instructions

- 1) Park vehicle on level hard surface. Engage emergency brake. Place blocks in front and behind rear wheels to prevent rolling. Observe all safety precautions and wear safety glasses.
- 2) Raise rear of vehicle allowing the axle to hang freely. Support the frame using safety jack stands.
- 3) Remove the factory bump-stops and set aside for re-installation. Remove 8mm hex screw from underside of the frame where 3/8 hex bolt (Item H) will be installed. Using the drill with the 3/8" drill bit open bigger the hole from which the 8mm screw was removed.
- 4) Remove the Upper Frame bracket (Item A) and place it against the chassis frame just forward of the axle with the large 0.62" hole in the bracket aligned with the large existing hole in the side of the frame (see above) and the slot in the horizontal plate of the bracket aligned with the hole in the bump-stop bracket from which the bump-stop was removed in 2 above.
- 5) Re-insert the factory bump-stop through the horizontal slot in the bracket and attach to the factory bump-stop bracket using nut and washer previously removed (see diagram above).
- 6) Attach the bracket to the side of the chassis frame using a 1/2-16 x 1 1/2" hex bolt (Item I) and a 1/2-16 Top-lock nut (Item K) and 1/2" steel washers (Item L). Likewise attach the bracket to the underside of the frame using a 3/8-16 x 1 3/4" hex bolt (Item H), 3/8-16 Top-lock nut (Item M) and washers (Item J).
- 7) Attach the bottom bracket (Item C) to the bottom of the Sumospring (Item B) using a 3/8-16 flat head cap-screw (Item F). Orientate the bottom bracket as per the schematic above ensuring that the Sumospring is positioned closest to the wheel relative to the slot in the bottom bracket and tighten the cap-screw. Install the Sumospring/lower bracket assembly and attach to the top bracket using two 3/8-16 x 3/4" serrated flange bolts (Item E).
- 8) Lower the jacks allowing the lower bracket to sit firmly on the factory spring-pack. Drop the two 3/8" x 4" carriage bolts into the lower bracket. Attach the u-bracket strap (Item D) and secure the 3/8 top-lock nuts (Item M) and washers (Item J).
- 9) We have an optional hole to attach to the side of the frame below the 1/2-16 connection in case the connection to the underside of the frame is obstructed and not possible. This would require a hole to be drilled into the side of the frame to accommodate the 3/8-16 bolt that would have been installed in the underside of the frame.
- 10) Repeat steps three through seven on the other side of the vehicle.
- 11) Jack up vehicle, remove safety jack stands.

- 12) Carefully lower vehicle to the hard surface. Remove the blocks in front and back of the rear wheels.
- 13) Release emergency brake.
- 14) Fill out warranty card and send to SuperSprings.

Important Notice

- 1) For easy installation please read instructions completely first and have all necessary tools available.
- 2) We recommend that this installation be done by a professional or persons with sound mechanical knowledge.
- 3) SumoSprings are designed to work with the original factory [springs](#) only.
- 4) These instructions are meant as a guide for the installation of SumoSprings. SuperSprings International assumes no liability for the actual installation process. Installers should apply common automotive safety practices when raising, lowering and working on vehicles.
- 5) SumoSprings are designed to enhance the vehicles load carrying performance and road handling however it does not authorize (or recommend) loading beyond the manufacturer's GVWR specifications.

To prevent damage to the vehicle and to ensure safety, do not exceed the maximum load recommended by the vehicles manufacturer (GVWR).

SumoSprings Rear

Suspension Enhancement
Workhorse Chassis Class A Motorhome [2001-2010]
W20, W22, W24
SumoSprings Part# SSR-280-54-1



Rear SumoSprings
SSR-280-54-1

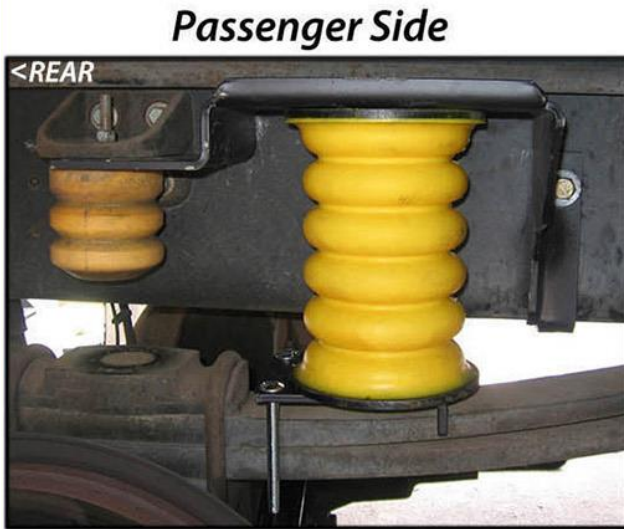

Passenger Side

Installed

SSR-280-54-1

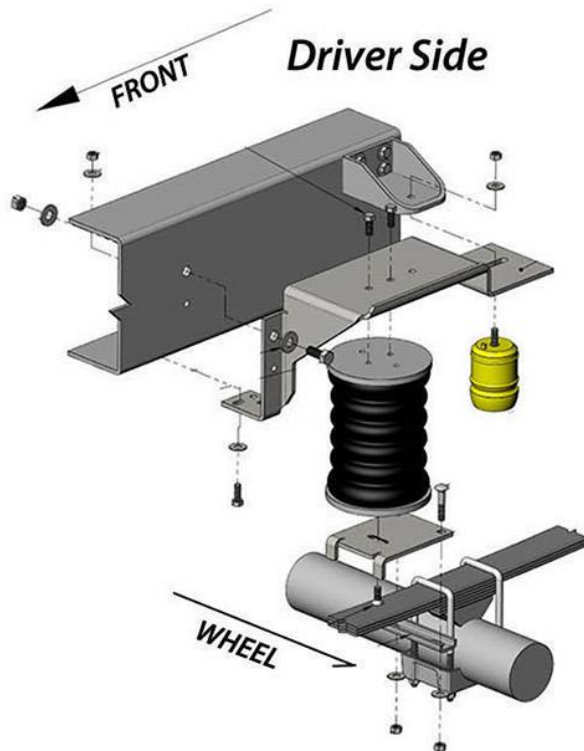

Installation