



Installation Instructions-Part # SS525-SS519

Rear Trac Bar

This product is designed to eliminate side shift of the rear axle
for Ford F5D 24,000+GVW Chassis
and 26k Kodiak 5500

Estimated installation time is 1.5 hours.

SS525 Trac Bar Parts Layout

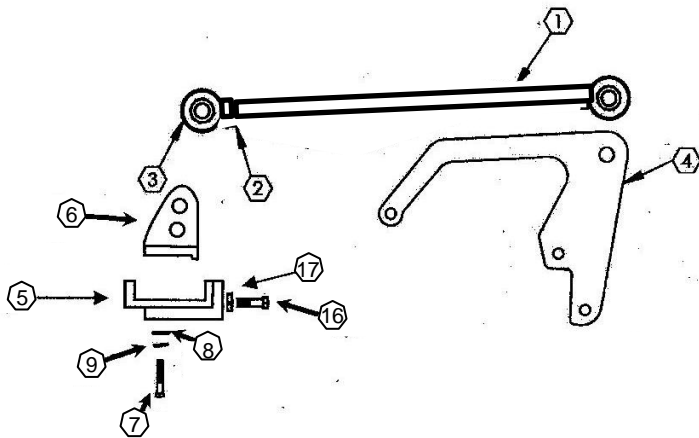
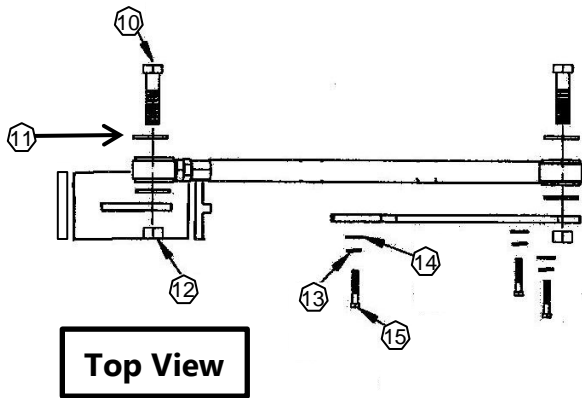

Item #	Description	Qty
1	SS 525 Rod Assy	1
2	Jam Nut – 3/4 16 UNF	1
3	Rod End Assy	1
4	Differential Bracket	1
5	Frame Bracket	1
6	Pinch Plate	1
7	5/8x 1 3/4" NF Bolts	2
8	5/8" Flat Washers	2
9	5/8" Lock Washers	2
10	3/4 x 3 16 UNF Bolts	2
11	Flat washers – 3/4	4
12	Top lock nut-3/4 16 UNF	2
13	Lock Washer 16mm	3
14	Flat Washer 16mm	3
15	Bolt 16x55mm	3
16	1/2" x 1 3/4" NF Bolts	2
17	1/2" NF Jam-nut	2

Item #	Torque Spec. (ft. lbs.)
2	100-150
7	100
10	150-180
15	120 -140 (metric 142-158)

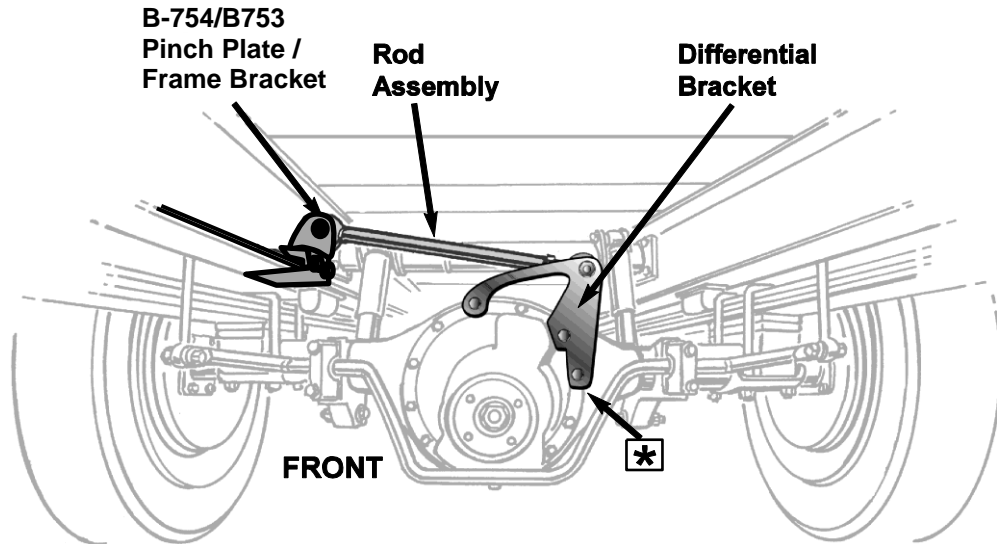

Installation Instructions - #SS525 Rear Trac Bar

1. *Preparation – Coach should be normally loaded*

Move the coach to a level, flat surface. If necessary, drive the rear wheels of the coach onto 4" high blocks and set the brakes or drive the coach over a work pit and chock the front wheels. Block off adequate space at the rear of the coach to work.

2. *Installation of the Differential Bracket*

Note: Before installing the differential bracket, make sure the surface is flat and clean. If letters or numbers are stamped or raised on the differential, smooth them away to create a flat surface.

Hold the differential bracket up to the differential to locate the 3 OEM bolts. Remove the bolts and discard. Swab the holes clean and dry before the installation of bolts. Loosely install the differential bracket to the differential with the supplied bolts: **Metric** (3) 16 x 55 mm. Be sure to use lock washers and flat washers, and apply Locktite to the bolts before installing. Torque bolts to spec.

3. *Installation of the Frame Bracket B-754 and Pinch Plate B-753*

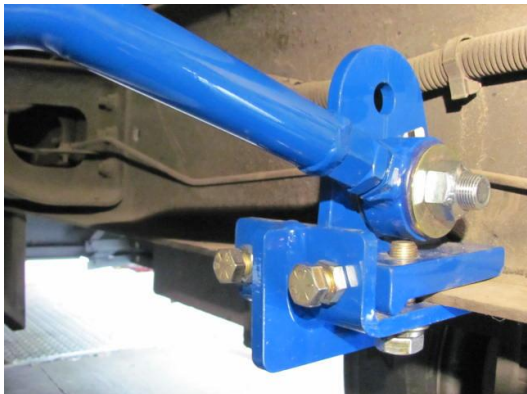

Passenger's side frame rail looking toward front of coach from coach rear (above rear axle).

Install the frame bracket B-754 and pinch plate B-753 on the frame rail. The frame must be between the pinch plate and the frame bracket. The frame bracket is designed to mount to the bottom and sides of the frame rail. Position the frame bracket below the frame rail on the passenger side in line with the axle bracket.

Align slotted holes in frame bracket with threaded holes in pinch plate. (Place the pinch plate with lip facing down and towards center of vehicle). Install (2) 5/8"x 1 3/4" fine threaded bolts, (2) 5/8" lock washers & (2) 5/8" flat washers. (*Use Loctite and tighten "just snug" for now*)

Note: Make sure not to contact any wires, brake lines, etc. This kit also includes zip ties and flexible plastic conduit should coach wiring needs to be moved or shielded.

Use the Trac Bar to check alignment from differential plate to frame bracket. Adjust forward or back. Then install the jam nuts onto the 1/2" fine threaded bolts and install in the frame bracket. Tighten to push the pinch plate against the inside of the frame, then tighten the bottom bolts securely. Now tighten the jam nuts against the bracket to lock the 1/2" fine threaded bolts into place and keep it from backing out.

4. **Installation of Rod Assembly**

Note: The rod assembly may be installed on the front or back of the brackets to achieve best clearance.

Install the rod assembly with the 3/4" x 3" bolts, flat washers and lock-nuts. Be sure that there is a flat washer on both sides of the urethane bushings of the rod end. When adjusting the length of the rod, it is necessary that the coach's full weight be on the suspension.

Tighten the 3/4" bolt and nut on the **differential bracket** to spec. Tighten 3/4" bolt and nut on the **frame bracket** to spec. Lastly, tighten the jam nut on the rod assembly to 110 ft. lbs.

5. **Final Instructions**

Test drive. Complete and mail the warranty card.

Re-check torque in 6 months.

Thank you for your purchase of the SuperSteer® Rear Trac Bar.