

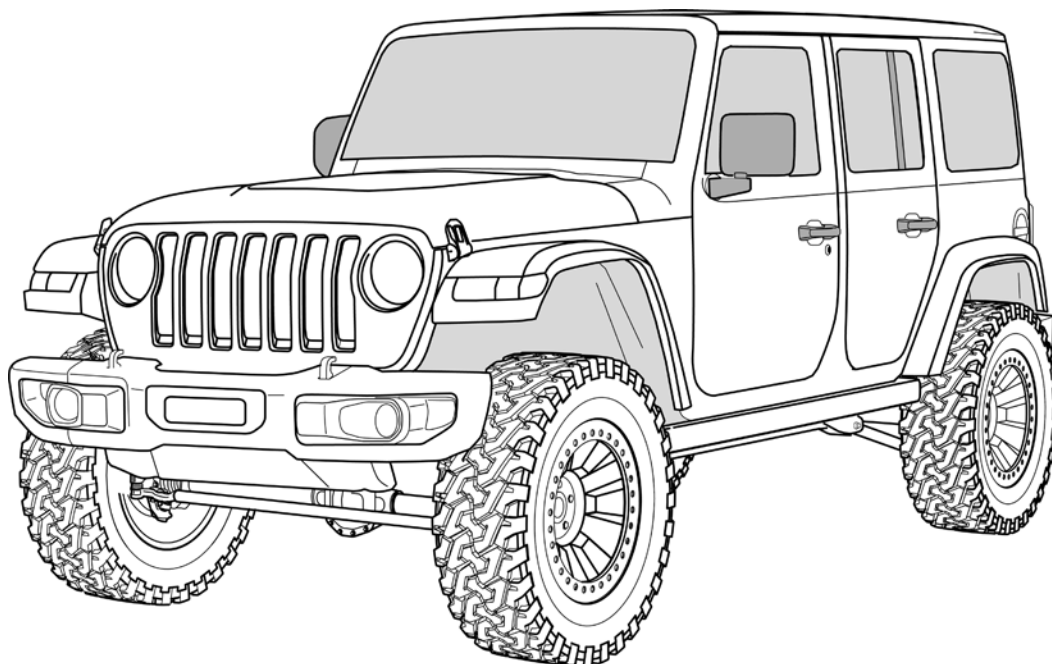

# Jeep JL 2.5" Spring Lift



## Important Notes:

Prior to beginning this install, or any installation, read the instructions thoroughly to familiarize yourself with the required steps. Evaluate if you are experienced and capable to personally perform these modifications. A factory service manual should be used in conjunction with these installation instructions.

This product will change the highway handling characteristics of your vehicle, exercise caution. After altering the suspension it is always advisable to have an alignment done by a competent 4 wheel drive shop or by an alignment shop that is experienced with lifted 4 wheel drive vehicles.

Refer to the parts list to ensure that all necessary components and hardware has been included. If any parts are missing please contact your local TeraFlex dealer for assistance.













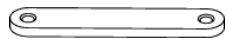

**If a 37" tire is being installed on a Sport or Sahara additional up travel limit may be required using Bumpstop Spacer Kit #1959300.**

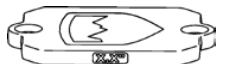
## Tools Needed:

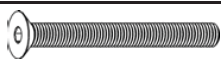
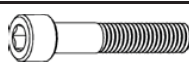
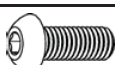

- Metric Sockets and Open End Wrenches
- Torque Wrench
- Factory Service Manual
- General Mechanics Tools

## Maintenance Note:

After the first 300 miles and every 3,000 miles after that, re-torque all the suspension components and bolts.

			Alpine CT2		Sport ST2		Base Spring Lift			
Description			Item #		4DR	2DR	4DR	2DR	4DR	2DR
	1	Front	02-21-201-250-1	2	-	2	-	2	-	
			02-21-301-250-1	-	2	-	2	-	2	
	2	Rear Left	02-22-211-250-1	1	-	1	-	1	-	
			02-22-311-250-1	-	1	-	1	-	1	
	3	Rear Right	02-22-221-250-1	1	-	1	-	1	-	
			02-22-321-250-1	-	1	-	1	-	1	
	4	Front Bumpstops	12-01-109-200	2	2	2	2	2	2	
	5	Rear Bumpstops	12-01-209-200	2	2	2	2	2	2	
	6	Rear Bumpstop Bracket	12-02-209-002	2	2	2	2	2	2	
	7	Rear Bumpstop Mounting Strap	12-02-209-001	2	2	2	2	2	2	
	8	Front Bumpstop Spacers	12-02-109-050	4	4	4	4	4	4	
	9	Rear Bumpstop Spacers	12-02-209-050	4	4	4	4	4	4	
	10	Front Swaybar link 10.75"	744500	2	2	2	2	2	2	
	11	Rear Swaybar Link 11.50	21-01-001-115	2	2	2	2	2	2	
	12	M10 x 1.5 Fuji Nut	23-07-03-001	6	6	6	6	6	6	
	13	M10 x 1.5 x 100mm Flat Socket Cap Screw	45-04-003-001	2	2	2	2	2	2	
	14	M10 x 1.5 x 50mm Socket Cap Screw	45-03-003-001	4	4	4	4	4	4	
	15	M10 x 1.5 x 25mm Button Socket Cap Screw	45-05-003-003	4	4	4	4	4	4	
	16	M10 Lock Washer	45-12-002-001	4	4	4	4	4	4	
	17	Nut Wrench Tool	600271	1	1	1	1	1	1	
	18	M12 x 1.75 x 55mm Button Socket Cap Screw	45-05-003-001	2	2	2	2	2	2	
	19	M12 x 1.75mm Black Fuji Nut	23-07-02-002	2	2	2	2	2	2	

Spring Box Components

			Alpine CT2		Sport ST2		Base Spring Lift			
			4DR	2DR	4DR	2DR	4DR	2DR		
Other Boxed Kits	Description		Item #		4DR	2DR	4DR	2DR		
		Jounce Bumpers Kit	1959200		1	1	1	1	-	-
		Alpine Control Arm Kit	1416510		1	1	-	-	-	-
	Sport Control Arm Kit	1253000		-	-	1	1	-	-	

Note: If installing Alpine Control Arm Kit Refer to Instruction #999321 before continuing.

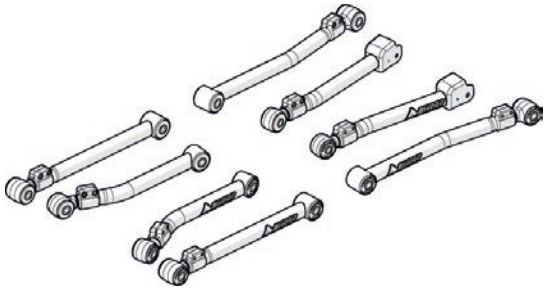

Note: If installing Sport Control Arm Kit Refer to Instruction #999325 before continuing.

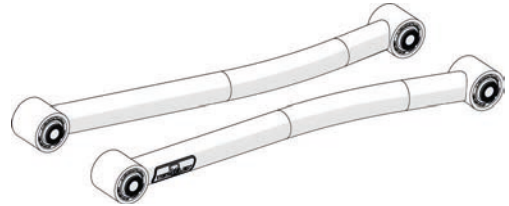

**\*LEAVE CONTROL ARM BOLTS LOOSE UNTIL THE END OF THE LIFT INSTALLATION\***

### FRONT INSTALLATION LIFT AND SUPPORT AT FRAME

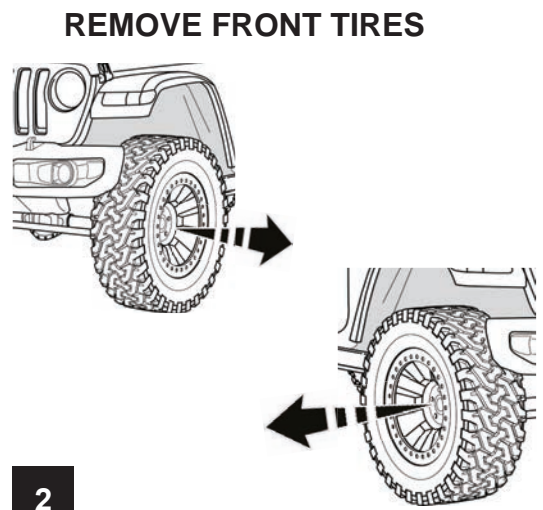
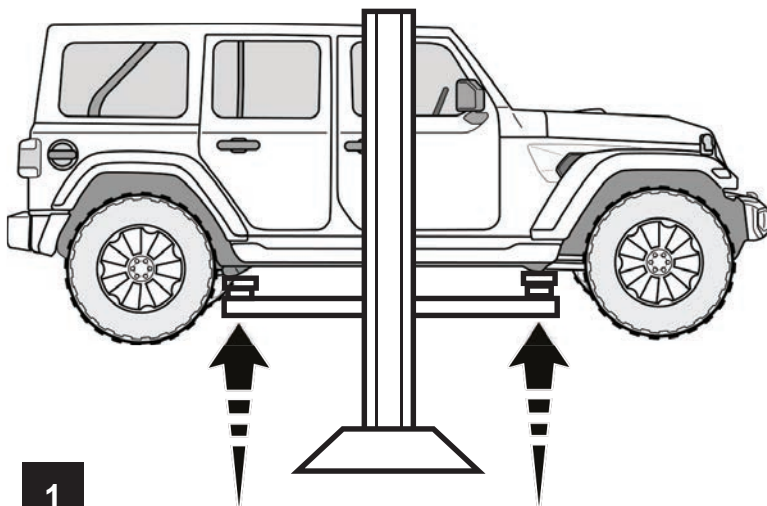
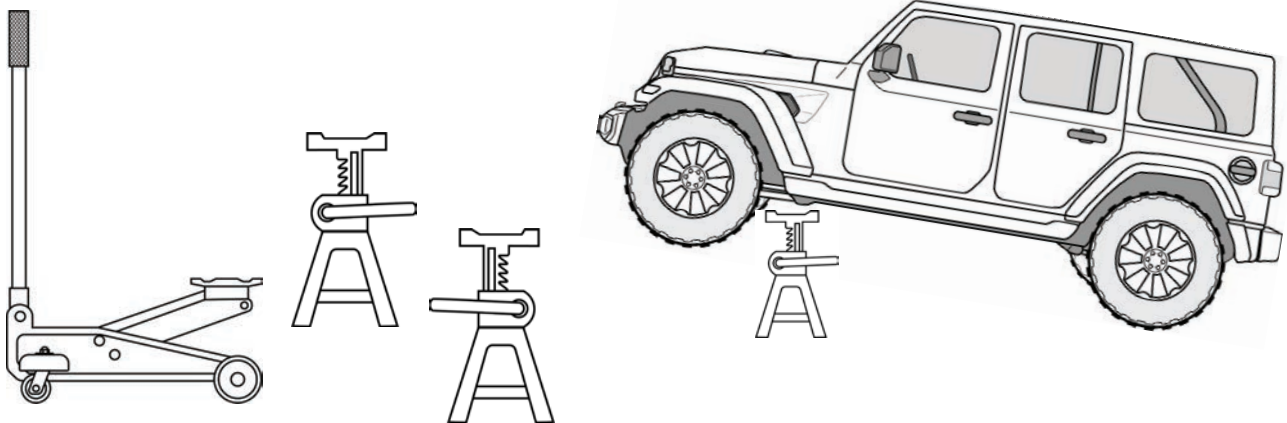

### REMOVE FRONT TIRES

### SUPPORT FRONT AXLE

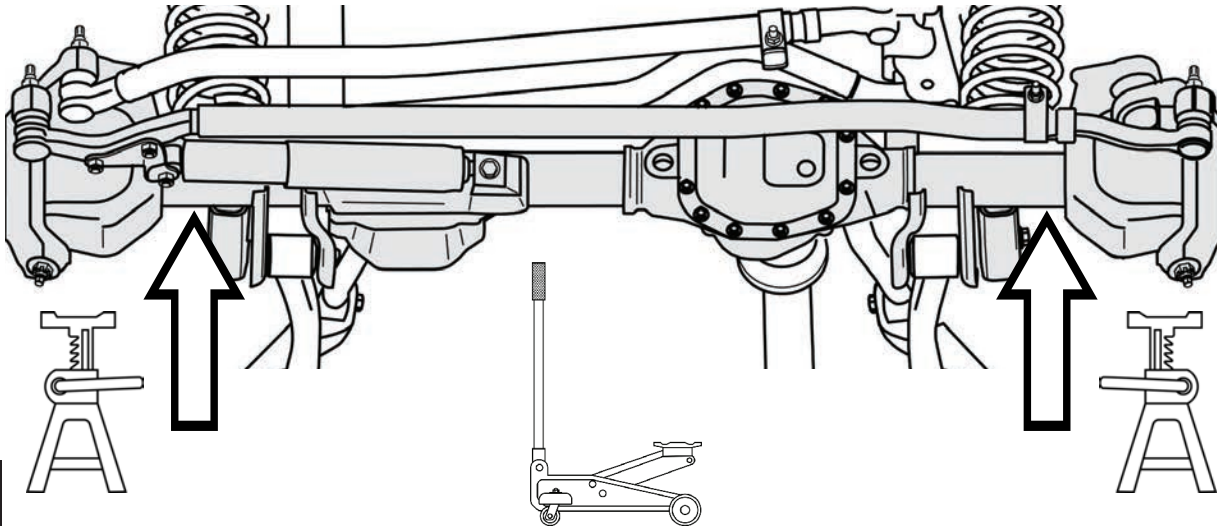

3

### REMOVE SWAY BAR LINKS & REMOVE TRACK BAR BOLT AT AXLE

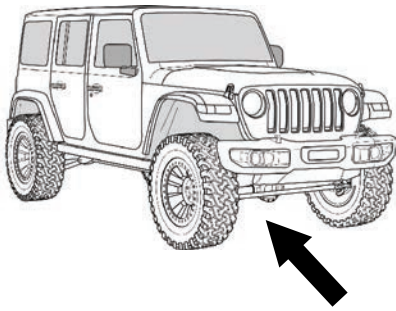

REMOVE &  
DISCARD

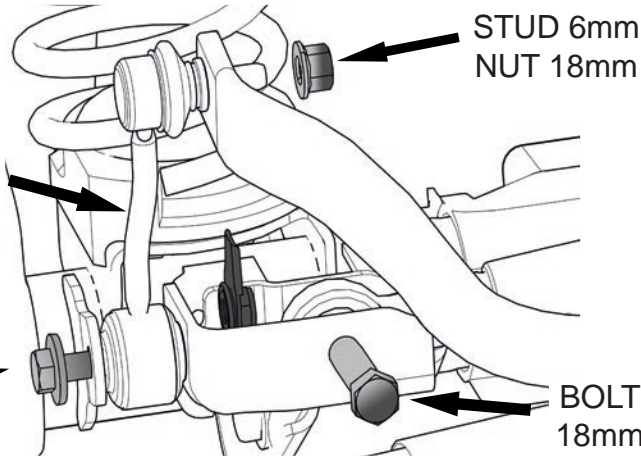

4

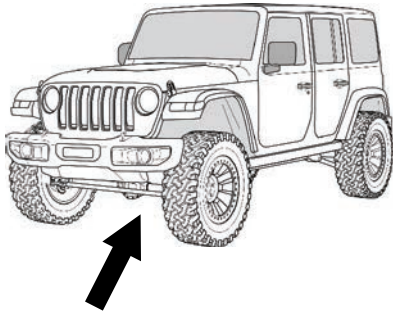

REMOVE NUT 18mm

STUD 6mm HEX KEY

REMOVE & DISCARD

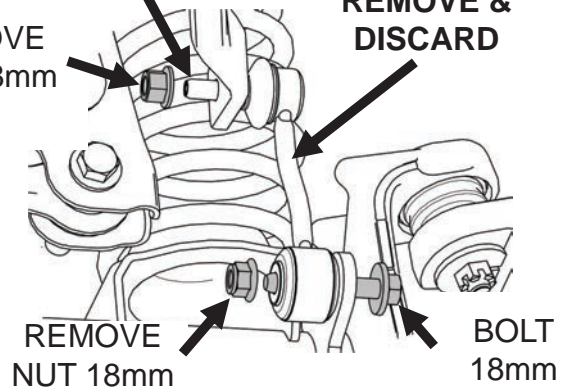

5

**REMOVE AND DISCARD BRAKE LINE BRACKETS FROM LOWER CONTROL ARMS**

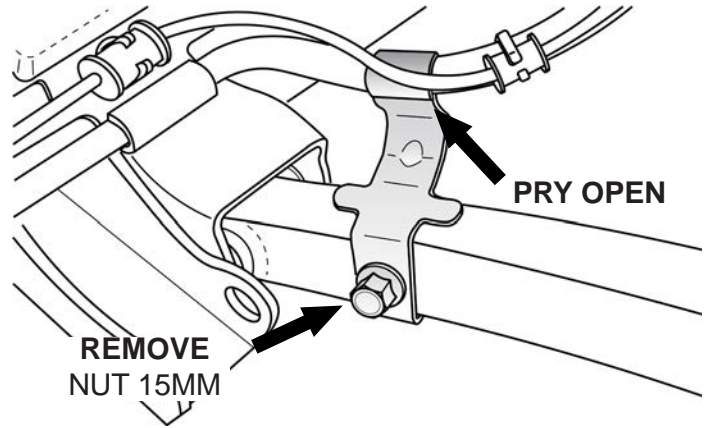
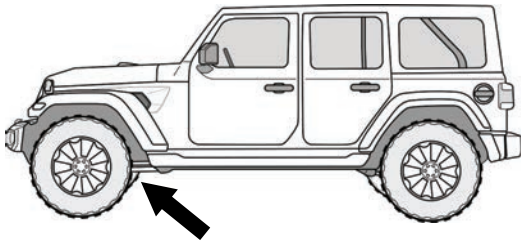
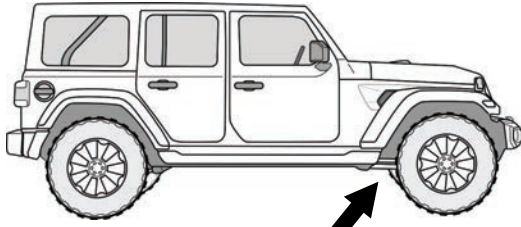

**2X**  
**6**

**DISCONNECT ACTUATORS AND VENT HOSE AT THE FRONT AXLE**

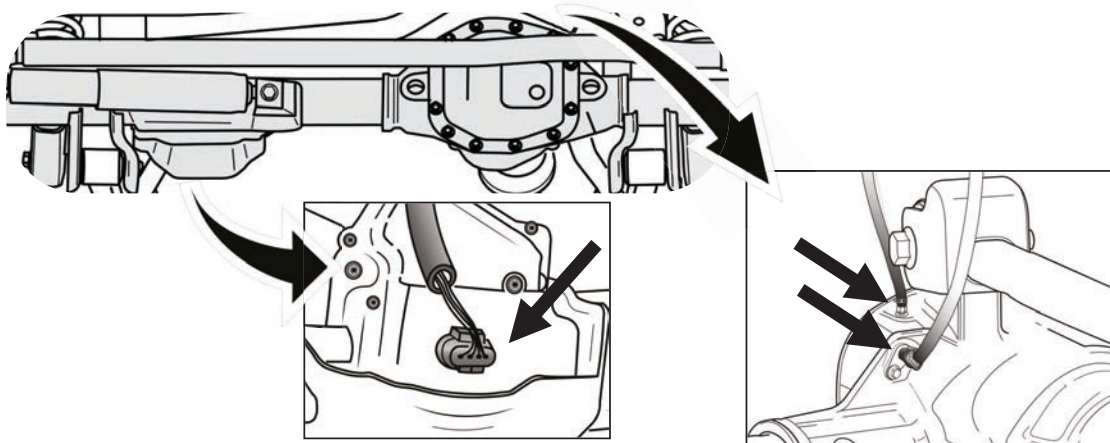

**7**

**LOOSEN FRONT CONTROL ARM BOLTS  
DO NOT REMOVE THE CONTROL ARM BOLTS**

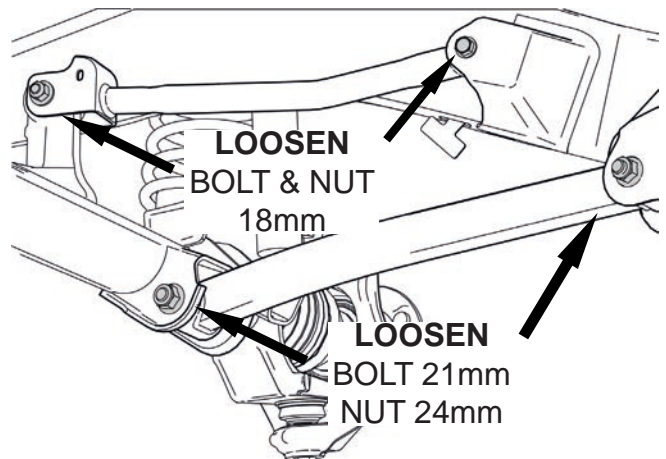
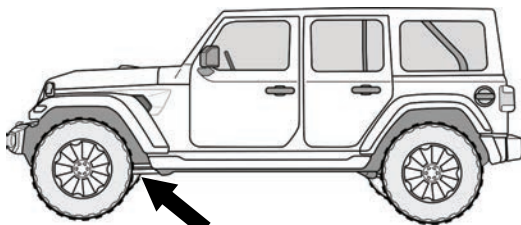
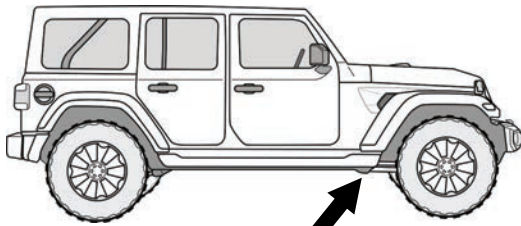

**2X**  
**8**

### REMOVE FRONT SHOCKS

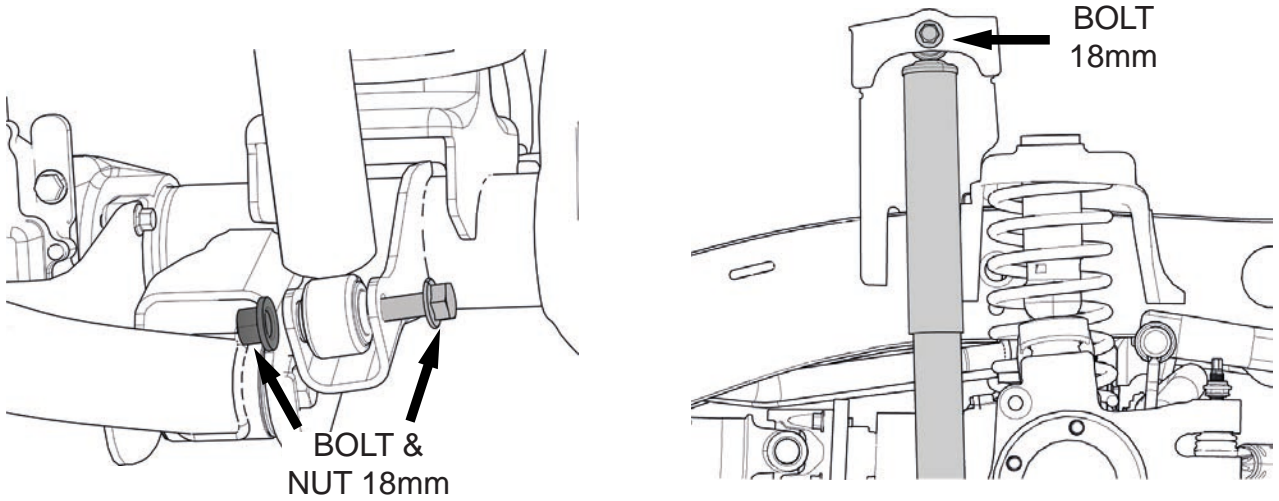

2X

9

BOLT & NUT 18mm

BOLT 18mm

### LOWER AXLE AND REMOVE FRONT SPRINGS

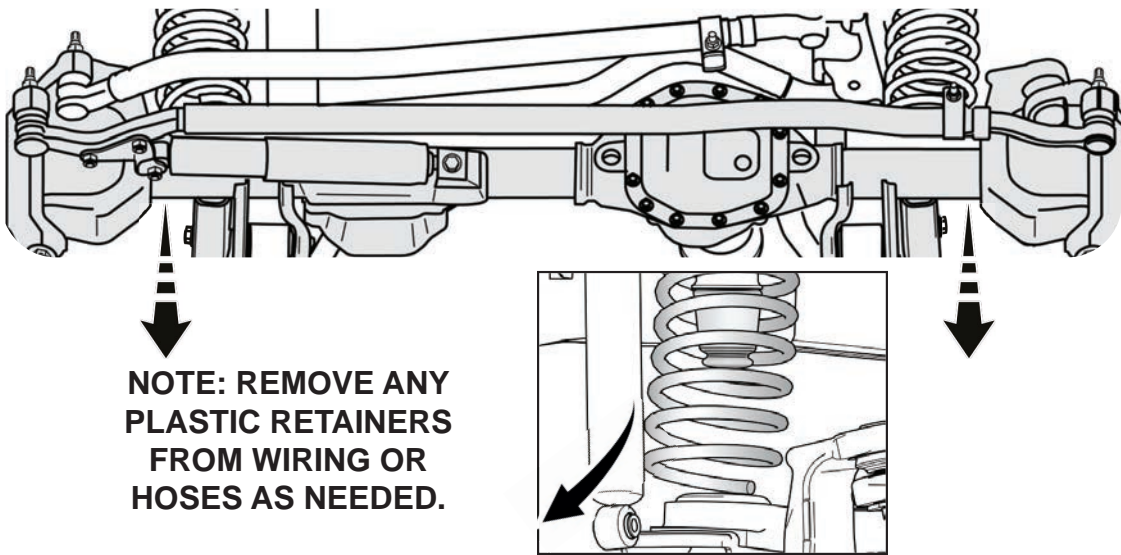

2X

10

NOTE: REMOVE ANY PLASTIC RETAINERS FROM WIRING OR HOSES AS NEEDED.

### INSTALL BUMPSTOP INTO NEW FRONT SPRING

Note: If installing Falcon Jounce Bumpers refer to instruction #999308 before installing springs.



2X

11

TIP: ZIP TIE BUMPSTOP TO SPRING

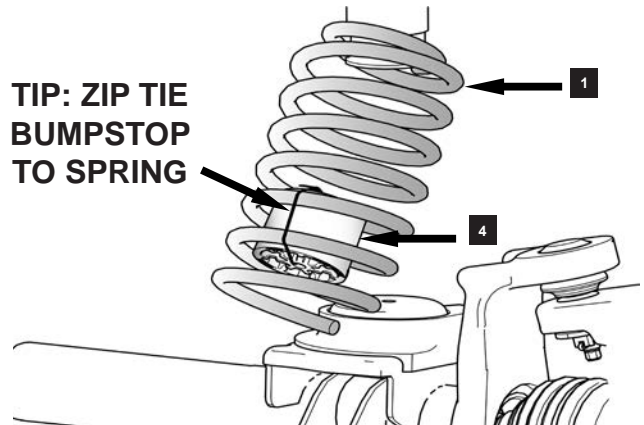

**NOTE: REFER TO PAGE 17 FOR BUMPSTOP SPACER GUIDE**

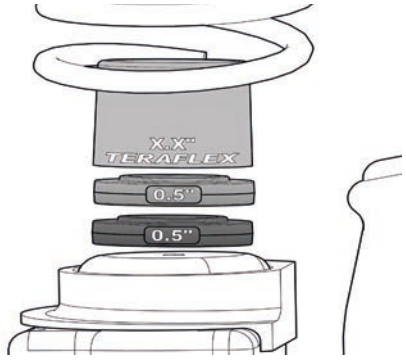

**2X**

**12**

**TORQUE 12 FT-LBS**

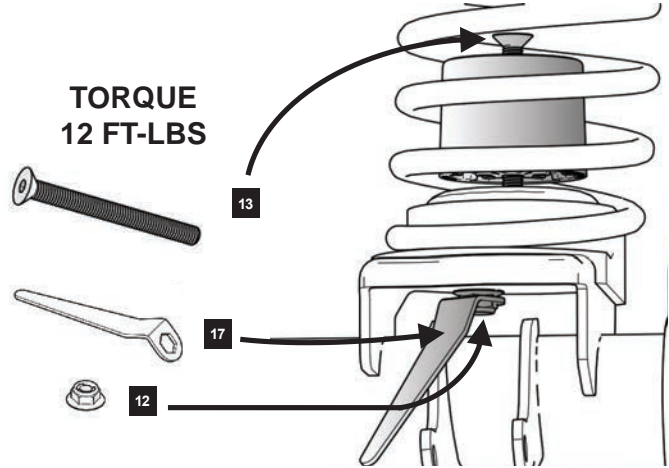

**FULLY SEAT THE SPRINGS INTO THE LOWER SPRING ISOLATOR**

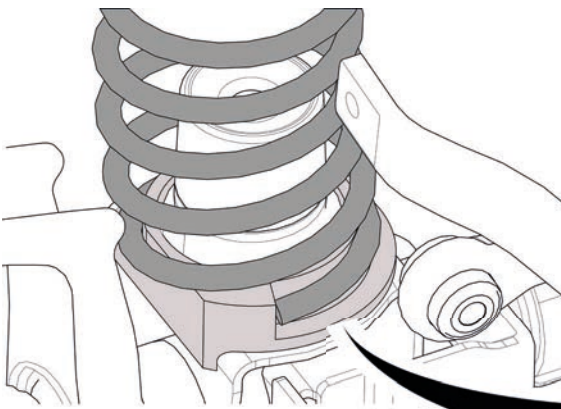

**2X**

**13**

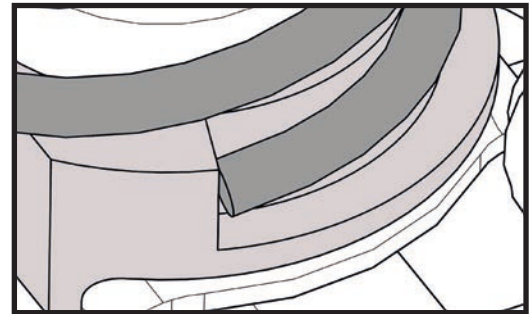

**RAISE AXLE & INSTALL SHOCKS**

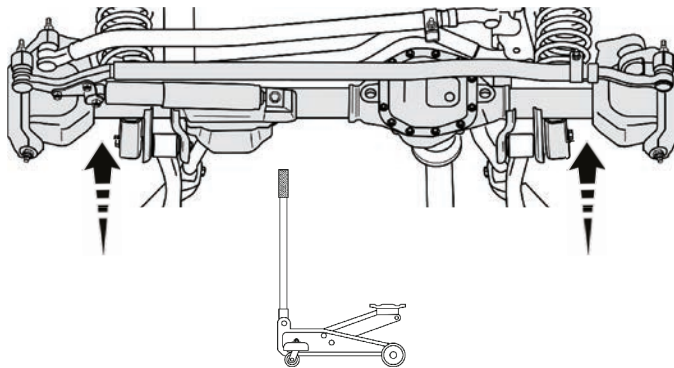

**14**

**INSTALL FRONT FALCON SHOCKS AT THIS TIME**

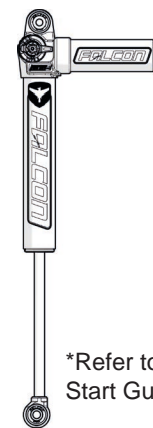

*\*Refer to the Quick Start Guide.*

**INSTALL NEW SWAY BAR LINKS**

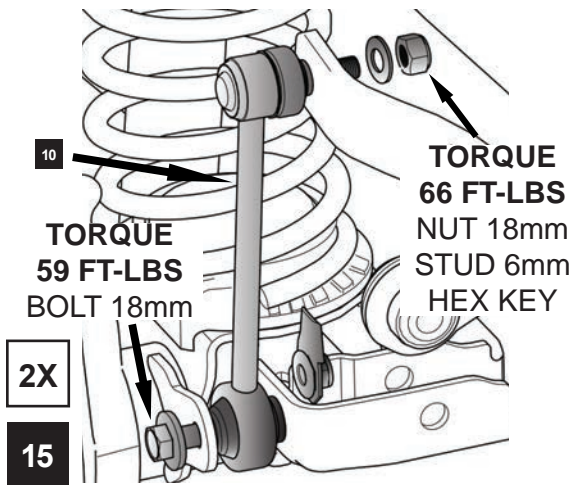

**RECONNECT CONNECTIONS TO FRONT AXLE**

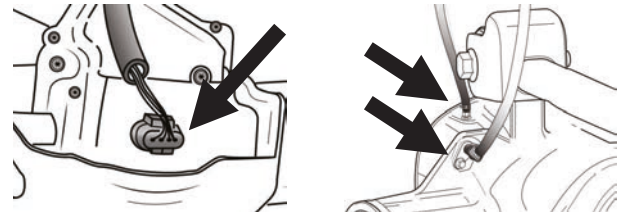

**RECONNECT PLASTIC RETAINERS FROM WIRING OR HOSES AS NEEDED.**

**NOTE: DO NOT TIGHTEN THE CONTROL ARM BOLTS UNTIL THE JEEP IS ON THE GROUND**

**16** **WAIT TO RE-INSTALL TRACK BAR UNTIL THE END OF THE LIFT KIT INSTALL.**

**NOTE: IF ONLY FRONT OF JEEP WAS LIFTED, REINSTALL TIRES AND LOWER JEEP BACK TO THE GROUND BEFORE LIFTING THE REAR**

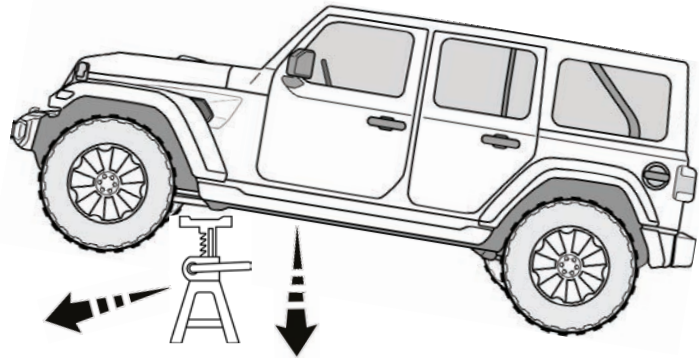
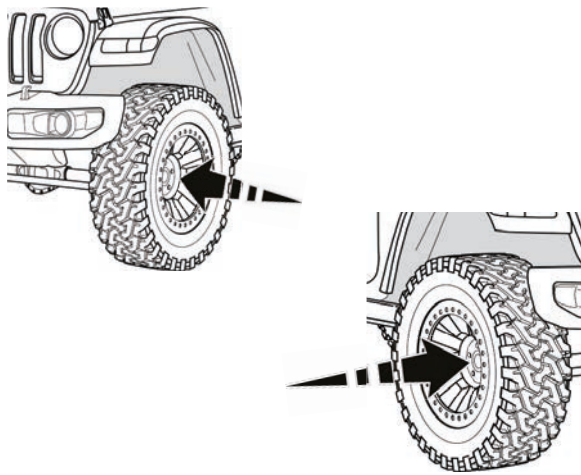

**\*TORQUE THE FRONT TIRES TO 130 FT LBS\***

### REAR INSTALL LIFT AND SUPPORT AT FRAME

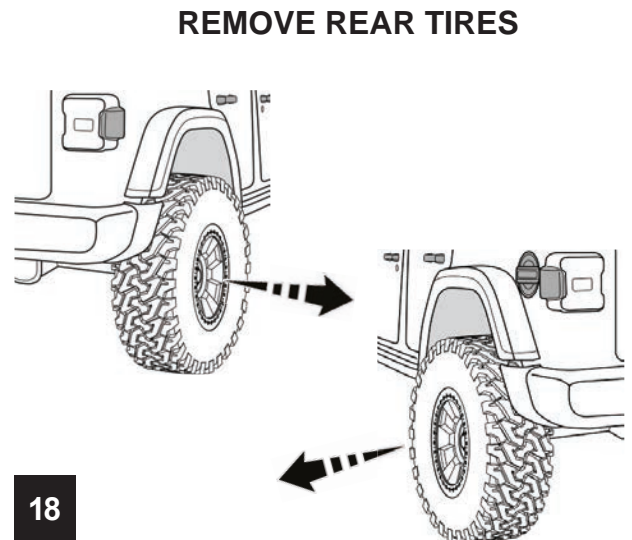
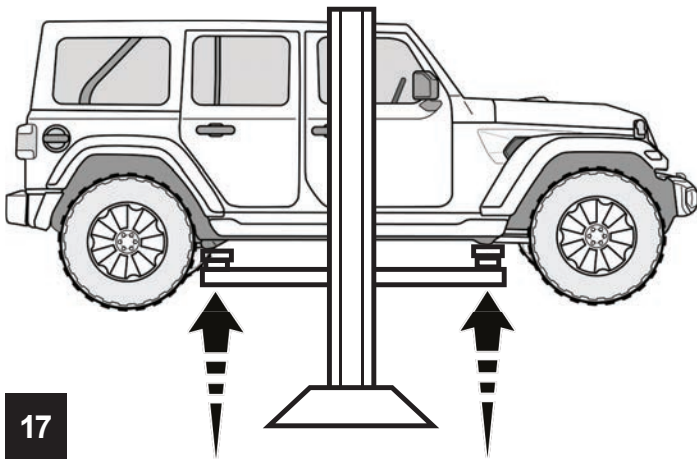
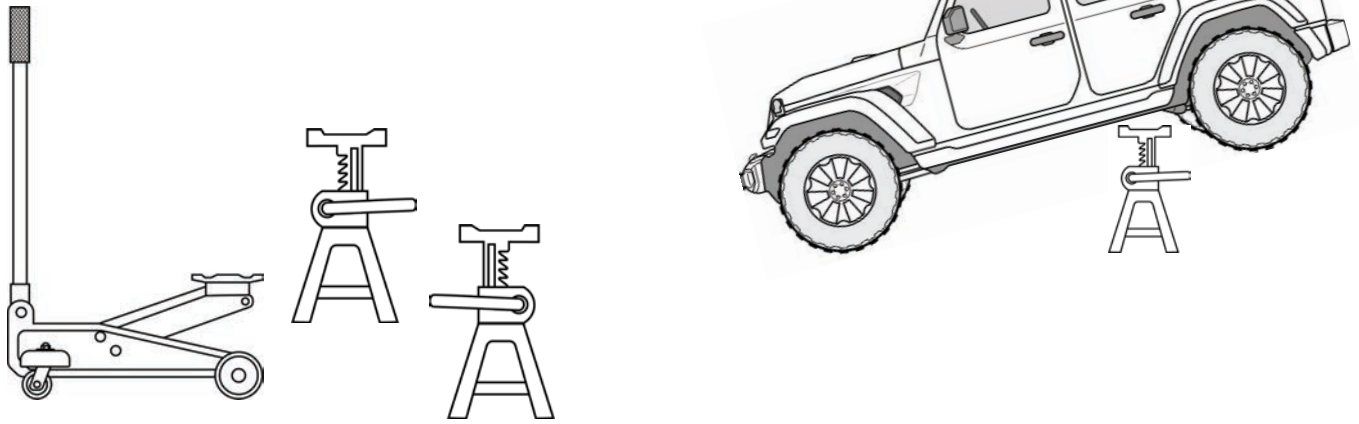

### SUPPORT REAR AXLE

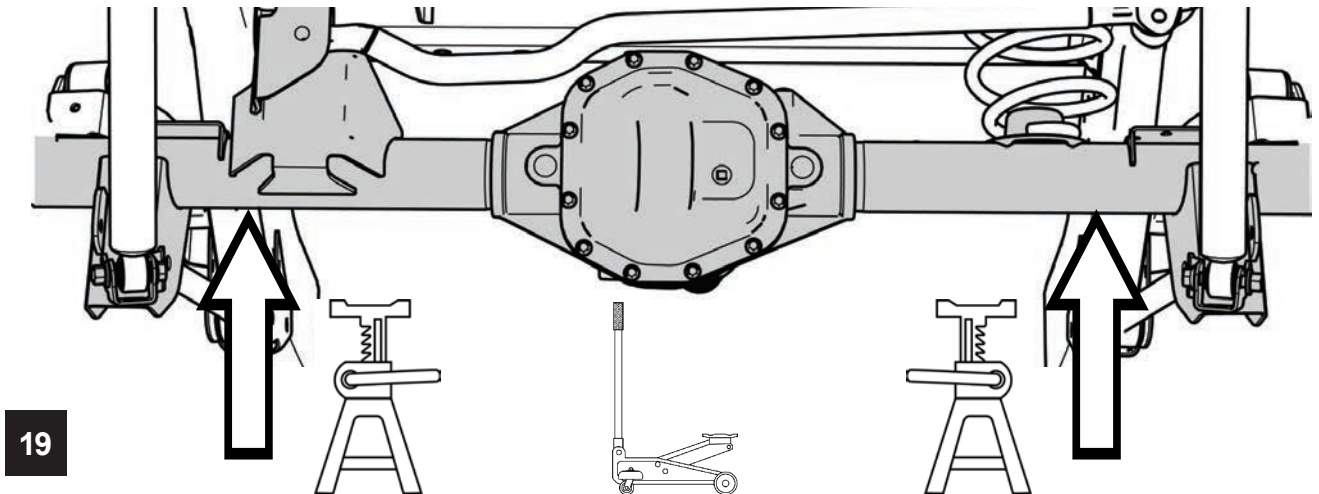

**REMOVE E-BRAKE CABLE BRACKET AND DISCARD**

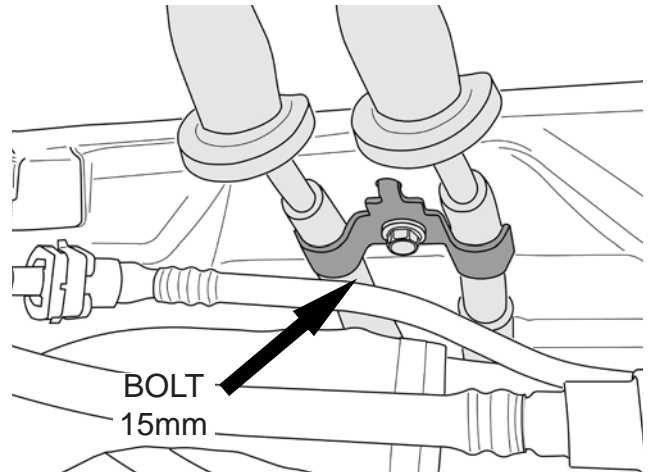
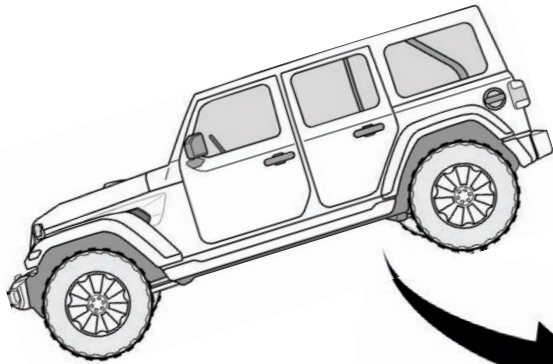

**20**

**SET THE E-BRAKE AND CLAMP BOTH E-BRAKE EYELETS AGAINST BACKING PLATES WITH LOCKING PLIERS**

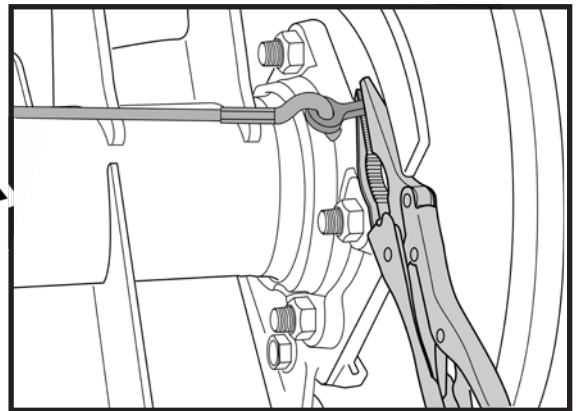
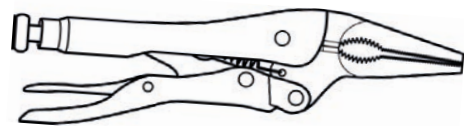
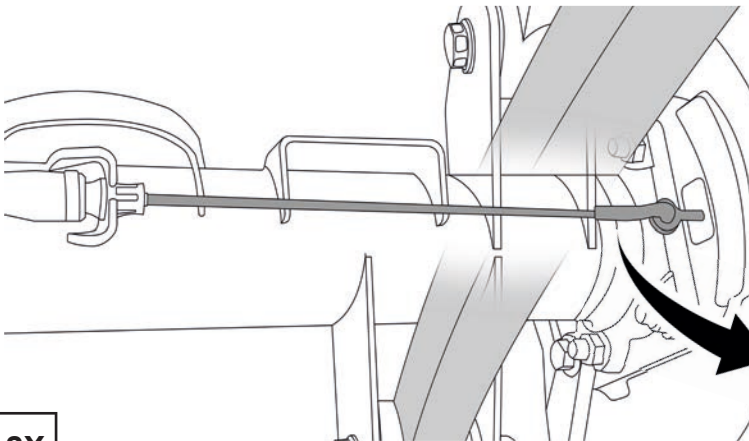

**2X**

**21**

**RELEASE E-BRAKE AND DISCONNECT CABLES FROM BOTH EYELETS AND AXLE BRACKETS**

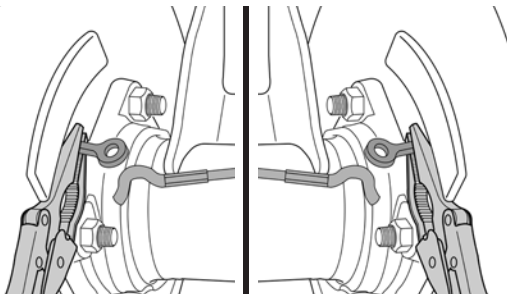

**2X**

**22**

**NOTE: DO NOT REMOVE LOCKING PLIERS FROM E-BRAKE EYELETS**

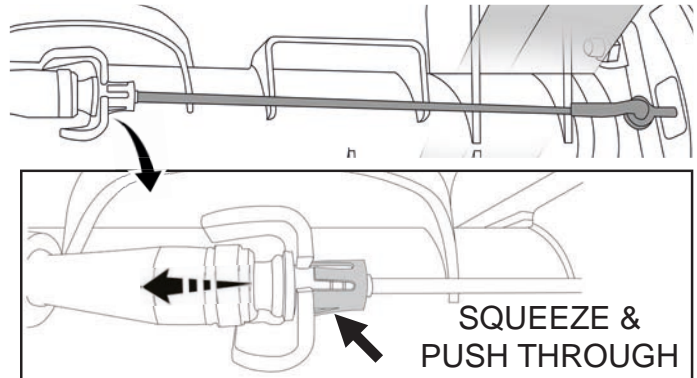

**SQUEEZE & PUSH THROUGH**

**ROUTE E-BRAKE CABLES UNDER CROSS MEMBER AND FUEL LINES.**

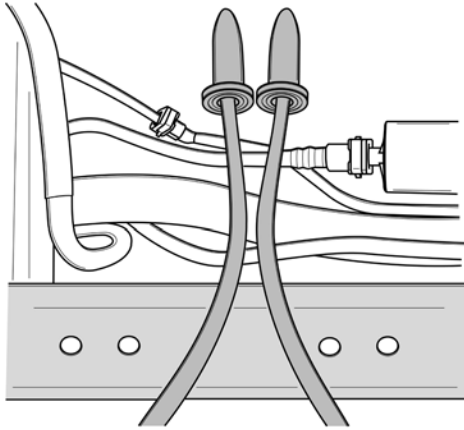

**23**

**RECONNECT E-BRAKE CABLES TO THE AXLE BRACKETS AND THEN THE E-BRAKE EYELETS.**

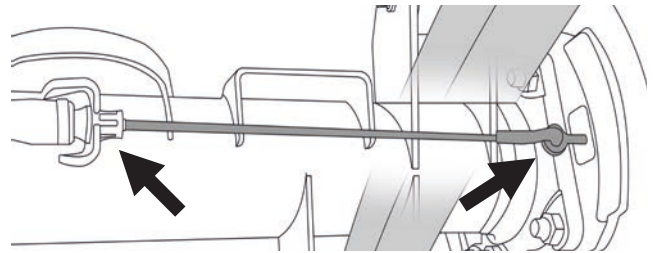

**2X**

**REMOVE PLIERS FROM E-BRAKE EYELETS**

**24**

**LOOSEN REAR CONTROL ARM BOLTS**

**DO NOT REMOVE THE CONTROL ARM BOLTS**

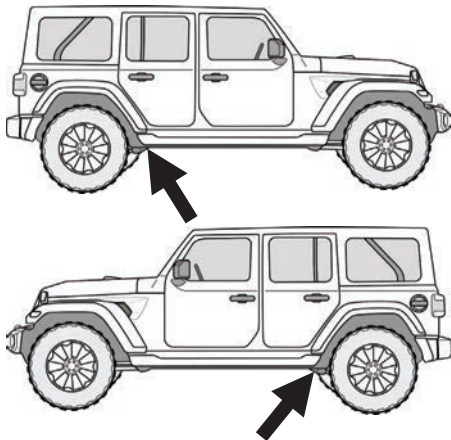

**2X**

**25**

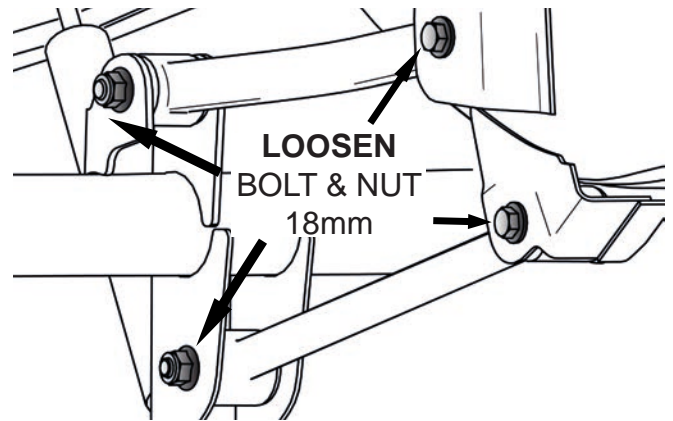

**REMOVE AND DISCARD SWAY BAR LINKS**

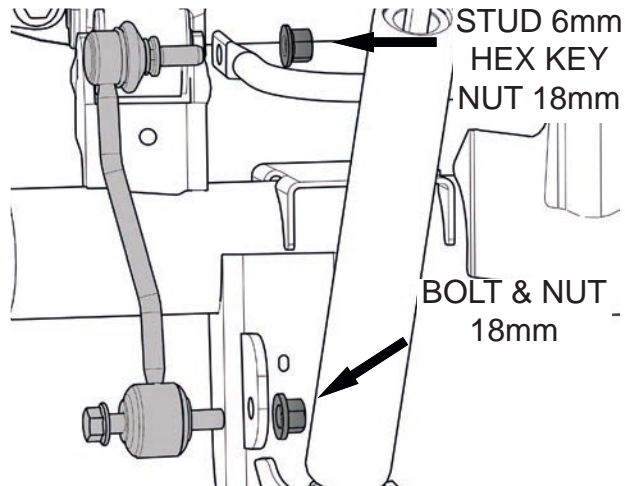

**2X**

**26**

**REMOVE BRAKE LINE BRACKETS FROM BOTH SIDES OF THE AXLE**

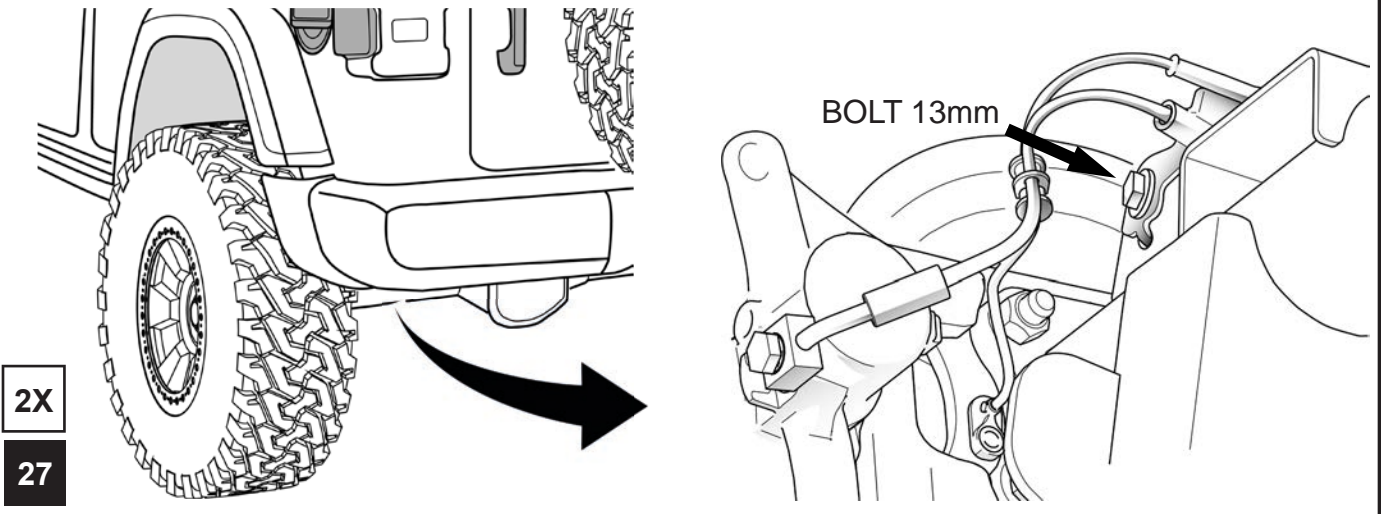

**REMOVE THE TRACK BAR FROM THE AXLE**

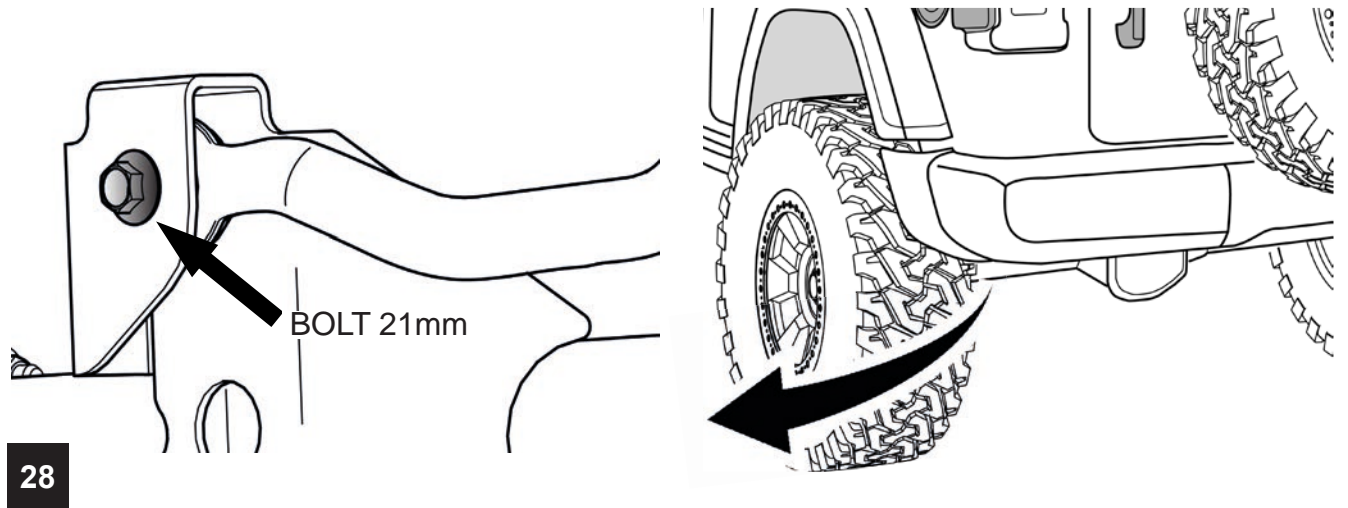

**REMOVE THE REAR SHOCKS**

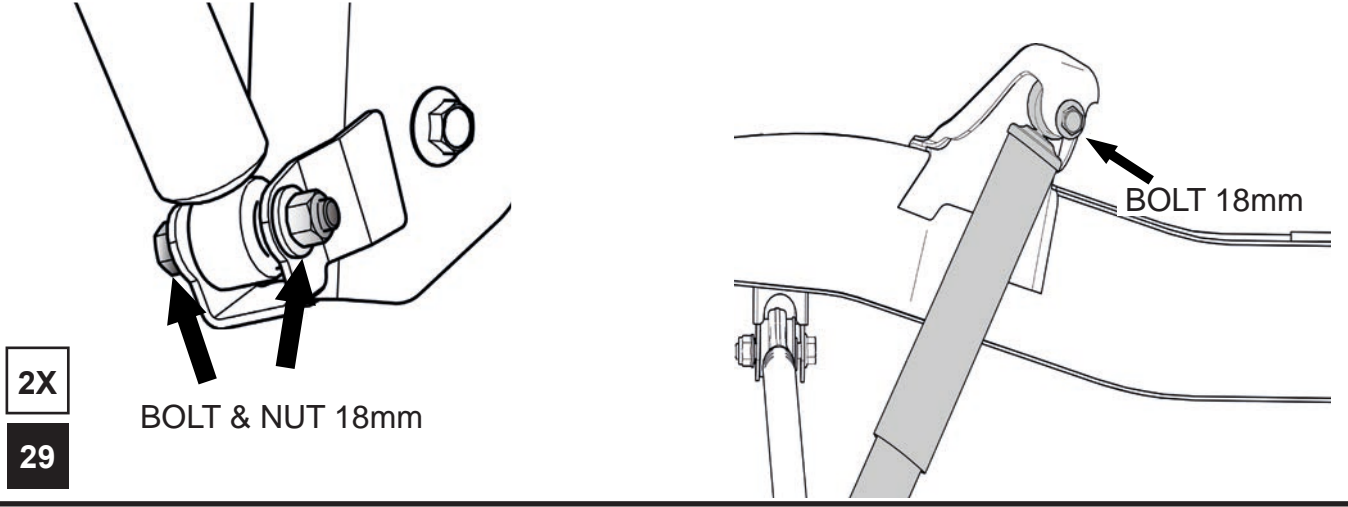

**LOWER AXLE TO REMOVE & DISCARD REAR SPRINGS**

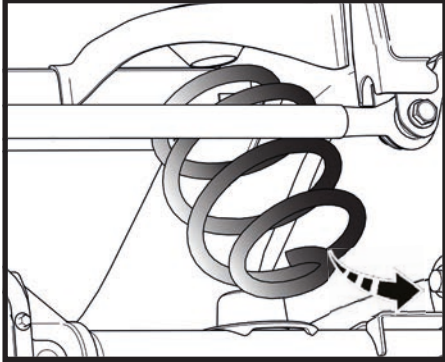
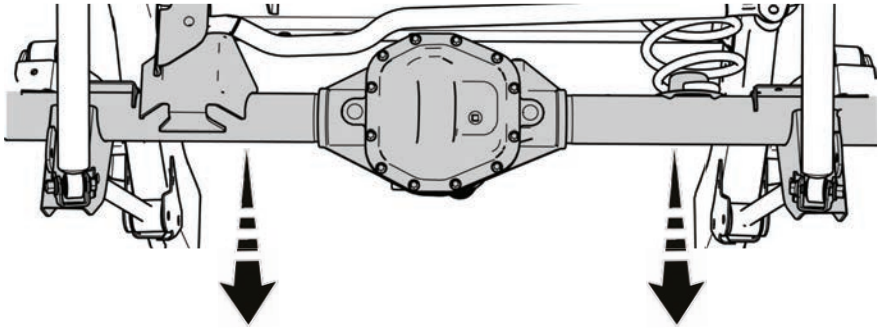

**NOTE: REMOVE ANY PLASTIC RETAINERS FROM WIRING OR HOSES AS NEEDED.**

**30**

**INSTALL NEW REAR SPRINGS**

**INSTALL THE DRIVERS SIDE SPRING FIRST**

**LEFT REAR SPRINGS**  
4 DOOR: 02-22-211-250-1  
2 DOOR: 02-22-311-250-1

**NOTE: PAY SPECIAL ATTENTION TO INSTALL THE CORRECT SPRING ON THE CORRECT SIDE OF THE JEEP. THE REAR SPRINGS ARE SIDE SPECIFIC.**

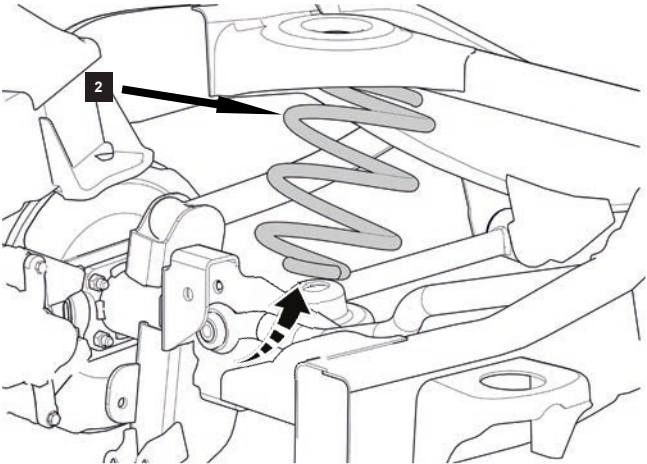

**31**

**INSTALL THE PASSENGERS SIDE SPRING**

**RIGHT REAR SPRINGS**  
4 DOOR: 02-22-221-250-1  
2 DOOR: 02-22-321-250-1

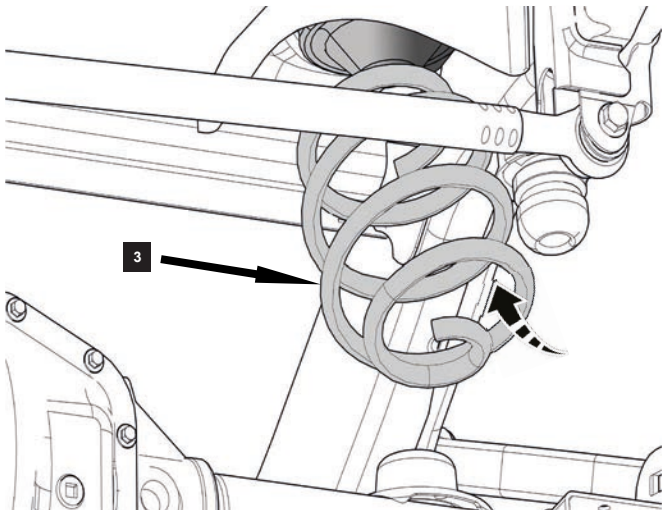

**32**

### RAISE THE REAR AXLE AND INSTALL SHOCKS

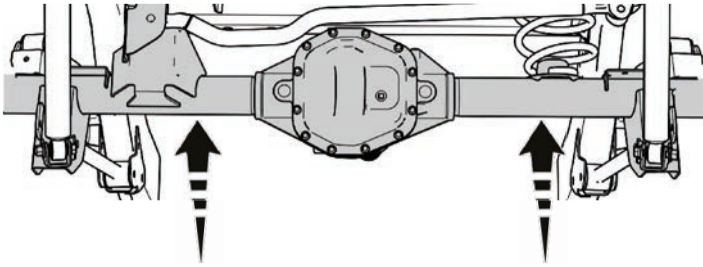

**MAKE SURE TO FULLY SEAT THE SPRINGS INTO THE UPPER SPRING ISOLATOR**

**33**

### INSTALL REAR FALCON SHOCKS AT THIS TIME

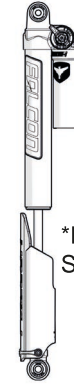

\*Refer to the Quick Start Guide.

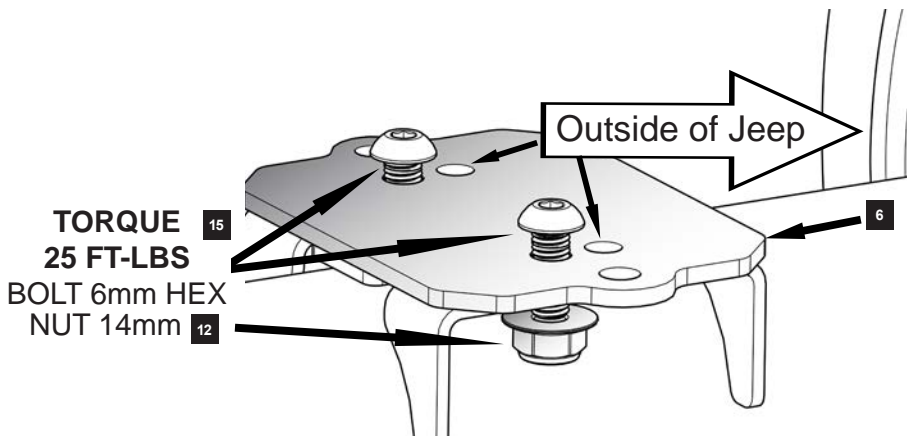

**TORQUE 25 FT-LBS**  
**BOLT 6mm HEX**  
**NUT 14mm**

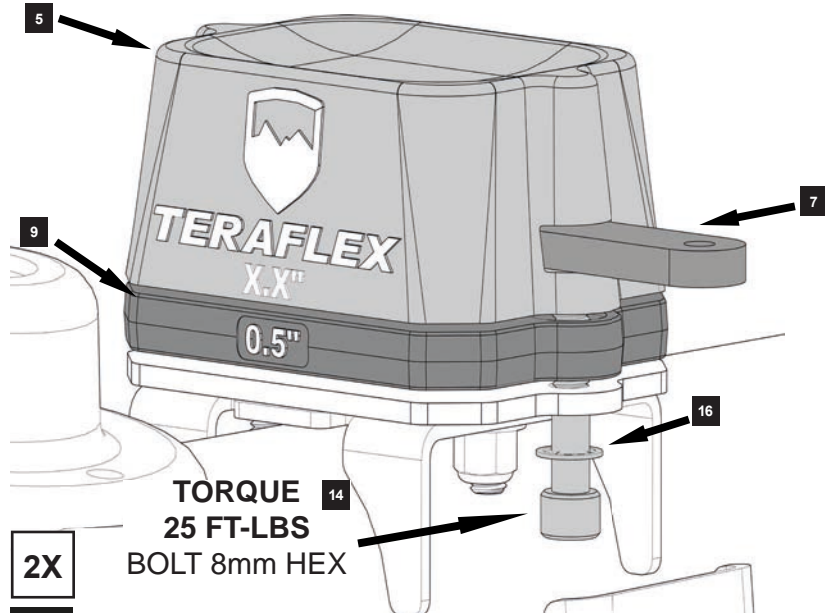

**TORQUE 25 FT-LBS**  
**BOLT 8mm HEX**

**2X**

**34**

### NOTE: REFER TO PAGE 17 FOR BUMPSTOP SPACER GUIDE

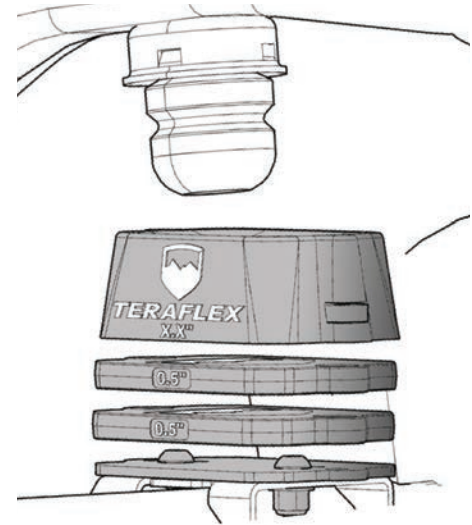

**REINSTALL BRAKE LINE BRACKETS**

**RECONNECT PLASTIC RETAINERS FROM WIRING OR HOSES AS NEEDED**

REINSTALL BOLT 13mm

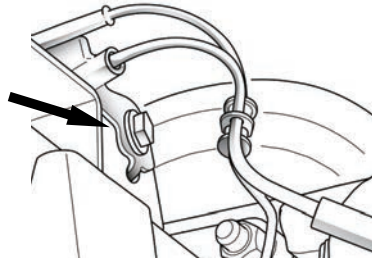

2X  
35

**NOTE: DO NOT TIGHTEN THE CONTROL ARM BOLTS UNTIL THE JEEP IS ON THE GROUND**

**INSTALL NEW SWAY BAR LINKS**

**TORQUE 45 FT-LBS**  
NUT 19 mm  
BOLT 8mm  
HEX KEY

**TORQUE 66 FT-LBS**  
NUT 19mm  
STUD 6mm  
HEX KEY

2X  
36

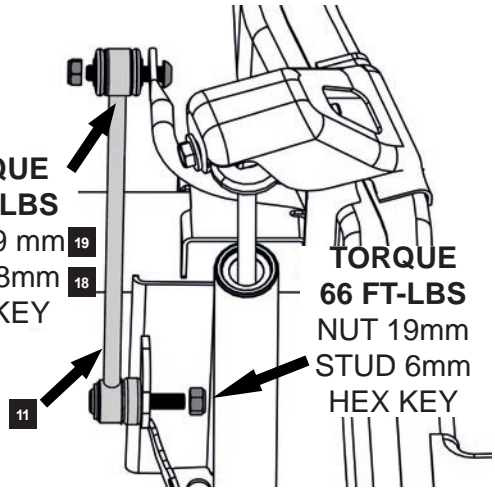

**REINSTALL TIRES AND LOWER TO THE GROUND**

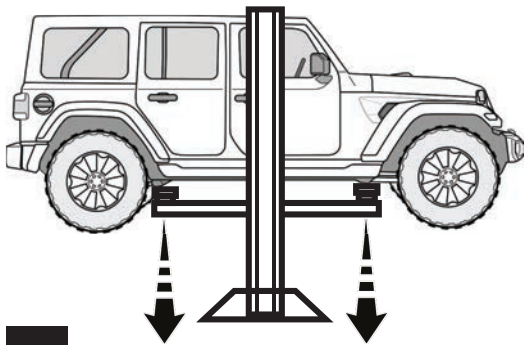

37

**TORQUE TO 130 FT LBS**

**REINSTALL TRACK BARS AND TORQUE TO THE FOLLOWING SPECS**

**TORQUE REAR**  
BOLT 21mm  
74 Ft Lbs + 60°

38

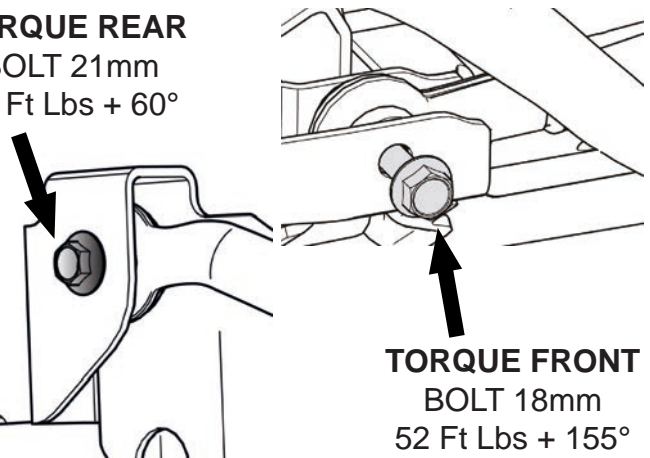

**TORQUE FRONT**  
BOLT 18mm  
52 Ft Lbs + 155°

**TORQUE CONTROL ARMS**

REAR

**TORQUE 21mm**  
74Ft Lbs + 65°

**TORQUE 21mm**  
74Ft Lbs + 80°

**TORQUE 21mm**  
74Ft Lbs + 50°

2X  
39

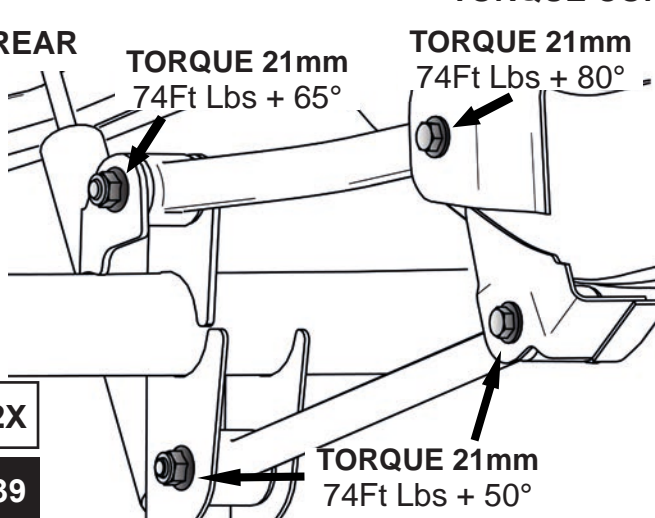

FRONT

**TORQUE 18mm**  
41Ft Lbs + 185°

**TORQUE 18mm**  
37 Ft Lbs +135°

**TORQUE 103 Ft Lbs +145°**  
BOLT 21mm  
NUT 24mm

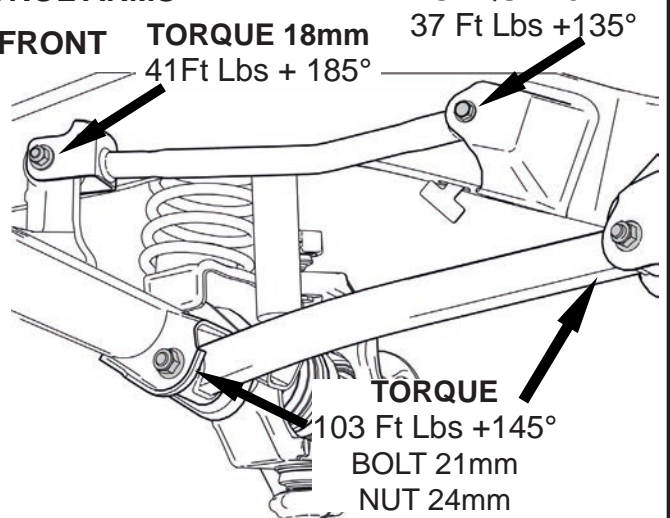

# JL Tire Clearance Guide (FACTORY FENDERS)

By limiting suspension up travel, TeraFlex Bump Stops allow the use of larger tires while keeping the factory fenders.

JL Rubicon models feature high-clearance fenders that allow for more up travel, while the lower-clearance fenders on JL Sport and Sahara restricts tire size due to fender rubbing.

In order to address these fender differences, TeraFlex designed a proprietary modular bump stop system, which can be adapted to fit several different lift height and tire size configurations.

In addition to the main 2" bump stop spacers, this system includes multiple 0.5" interlocking spacers that can be added to fine tune bump stop height to limit suspension up travel.

JL RUBICON

## JL Rubicon with Factory Fenders:

See Notes: Not all Tires Measure the Same

- 33" - No Bump Stops
- 35" - 2" Front & 2" Rear Bump Stops



- 37" - 2.5" Front & 3" Rear Bump Stops

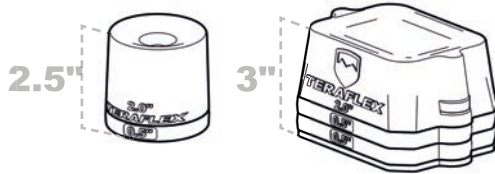

JL SPORT/SAHARA

## JL Sport/Sahara with Factory Fenders:

See Notes: Not all Tires Measure the Same

- 33" - No Bump Stops
- 35" - 3" Front & 2.5" Rear Bump Stops

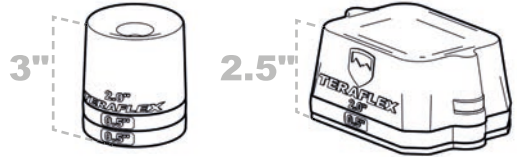

- 37" - 3.5" Front & 4" Rear Bump Stops

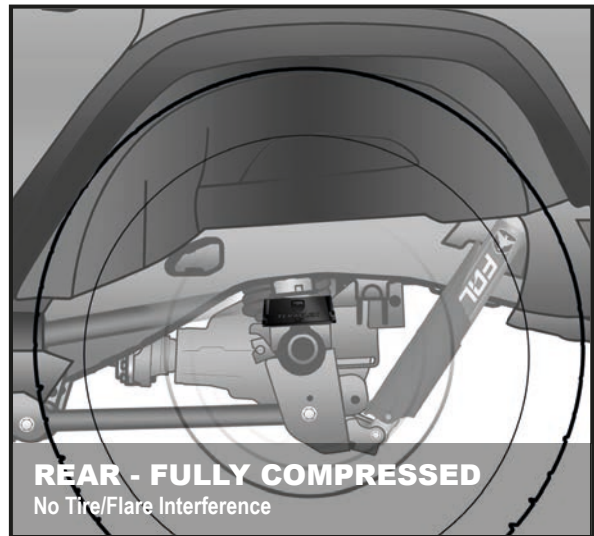
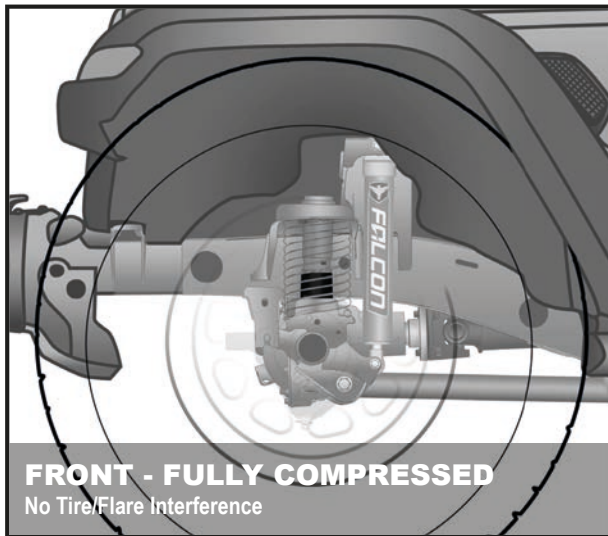
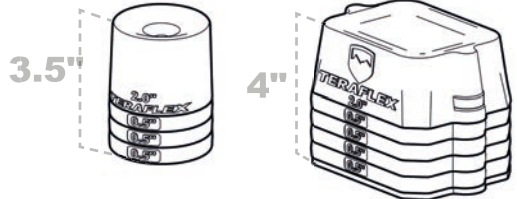

## 2-4 Inch Shock Options

### JL Falcon Adjustable PiggyBack Shocks

- 4 Door Series 3.3, 11-01-33-400-200-3
- 2 Door Series 3.3, 10-01-33-400-200-3

- \*Fast Adjust Knob
- \*High Flow Oil Channel
- \*Offset Sleeve Design
- \*PiggyBack Reservoir

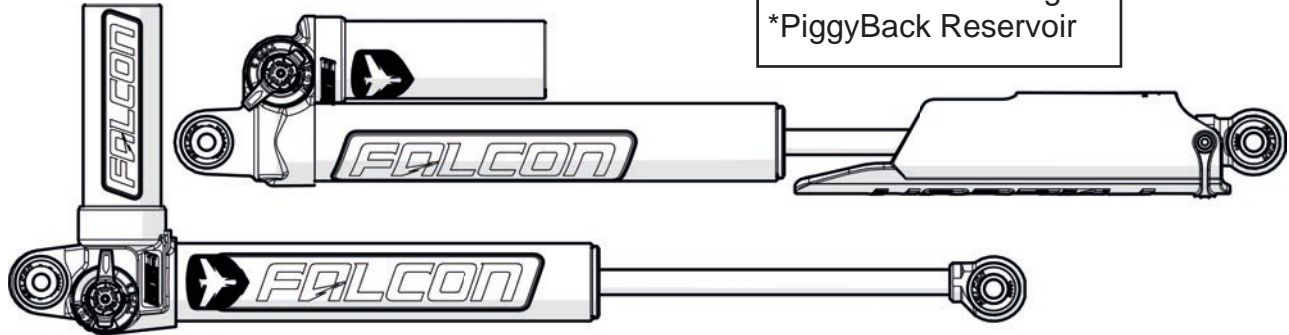

### JL Falcon PiggyBack Shocks

- 4 Door Series 3.1, 11-01-31-400-200-3
- 2 Door Series 3.1, 10-01-31-400-200-3

- \*Series 3.3 Upgradable
- \*High Flow Oil Channel
- \*Offset Sleeve Design
- \*PiggyBack Reservoir

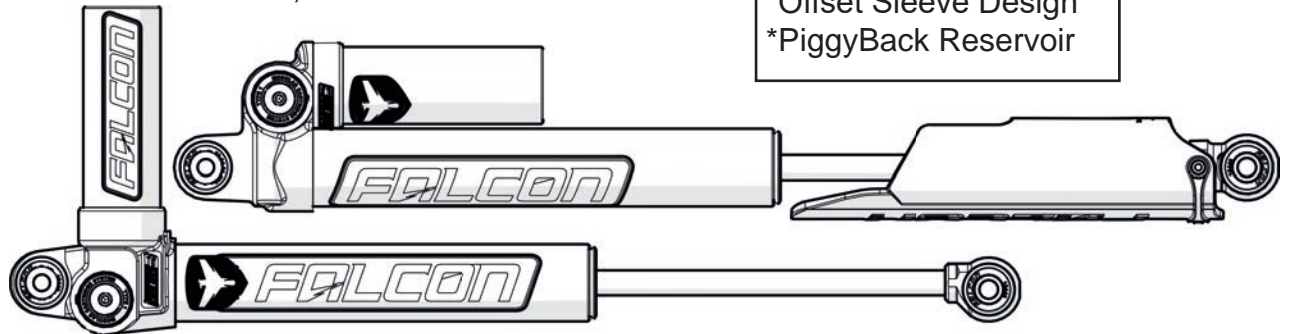

### JL Falcon Monotube Shocks

- 4 Door Series 2.1, 11-01-21-400-200-3
- 2 Door Series 2.1, 10-01-21-400-200-3

- \*Oil Gas Separator
- \*3/4" Chrome Shaft
- \*Offset Sleeve Design
- \*JL Specific Shock



# TERAFLEX

## PRODUCT INFORMATION

### MAINTENANCE INFORMATION:

It is the buyer's responsibility to have all suspension, drivetrain, steering, and other components checked for proper tightness and torque after the first 100 miles and every 3000 miles after that.

### NOTICE TO INSTALLER:

The enclosed "Warning to Driver" sticker must be installed in the vehicle in driver's view. This sticker is to act as a constant safety reminder when operating the vehicle. It is your responsibility as the equipment installer to install the provided sticker and to forward the product instructions to the vehicle's owner for review. If a "Warning to Driver" sticker or product installation guide were not included in the kit, FREE replacement stickers and instructions are available by request. It is the installer's duty to ensure a safe and controllable vehicle after the modifications have been performed.

### WARNING:

Neither the seller nor the manufacturer will be liable for any loss, damage, or injury directly or indirectly arising from the use of or inability to determine the use of these products. Before using, the user shall determine the suitability of the products for its intended use, and the user shall assume all responsibility and risk in connection therewith.

### WARNING TO DRIVER:

This vehicle has been modified to enhance off road performance and has unique handling characteristics. Use in harsh environments can cause extreme stress on the components. Vehicle should be inspected after being off road to make sure that all the components are in working order and safe to travel on the highway. All fasteners should be checked so that they are at the correct torque specifications as the vibration and stresses from off roading may cause critical fasteners to work loose. Extra care should be taken to inspect the critical components, steering, and brake systems. During each oil change components such as arms, tie rod ends, etc should be greased and checked for excessive wear. Any worn components should be replaced. When returning to the pavement always set or restore tire air pressure to the factory recommendation and connect or engage any disabled sway bar mechanisms. Because of the higher center of gravity and larger tires, this vehicle handles and reacts differently than many passenger cars, both on and off road. You must drive it safely! Extreme care should be taken to prevent vehicle rollover or loss of control, which can result in serious injury or death. Avoid sudden sharp turns or abrupt maneuvers. Generally, braking performance and capabilities are decreased when significantly larger/heavier tires are used, especially when used in combination with transfer case low-range reduction kits. Take this into consideration while driving. Do not add, alter or fabricate any factory or aftermarket parts to increase vehicle height over the intended height of the TeraFlex product purchased. Mixing component brand is not recommended. TeraFlex Inc. will not be responsible for any altered product or any improper installation or use of our products. We will be happy to answer any questions concerning the design, function, and correct use of our products. It is ultimately the buyer's responsibility to have all bolts/nuts checked for tightness after the first 100 miles and then every 3000 miles. Wheel alignment, steering system, suspension and drive line systems must be inspected by a qualified professional mechanic at least every 3000 miles.