

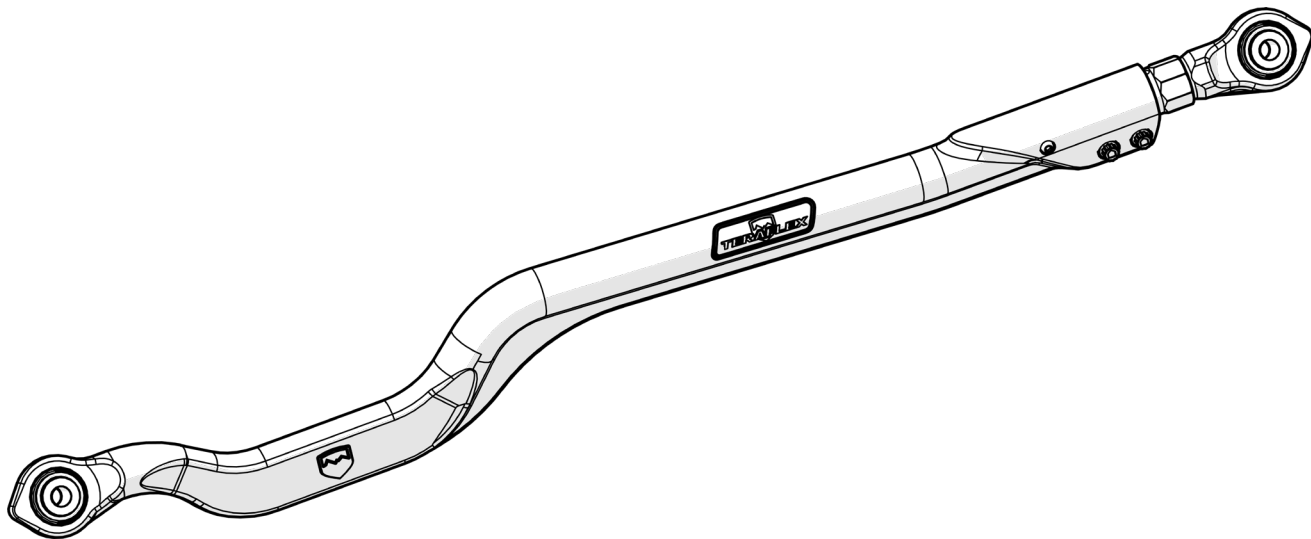

# JL REAR TRACK BAR

# 1754420



## Important Notes:

Prior to beginning this install, or any installation, read the instructions thoroughly to familiarize yourself with the required steps. Evaluate if you are experienced and capable to personally perform these modifications. A factory service manual should be used in conjunction with these installation instructions.

This product will change the highway handling characteristics of your vehicle, exercise caution. After altering the suspension it is always advisable to have an alignment done by a competent 4 wheel drive shop or by an alignment shop that is experienced with lifted 4 wheel drive vehicles.

Refer to the parts list to ensure that all necessary components and hardware has been included. If any parts are missing please contact your local TeraFlex dealer for assistance.

**When reinstalling OEM hardware, refer to the torque specs given in the Factory Service Manual.**

### Tools Needed:

- Metric Sockets and Open End Wrenches
- Torque Wrench
- Factory Service Manual
- General Mechanics Tools

### Maintenance Note:

After the first 300 miles and every 3,000 miles after that, re-torque all the suspension components and bolts.

**ADJUST NEW TRACK BAR TO APPROXIMATE LENGTH NEEDED  
TO CENTER AXLE UNDER JEEP**

**STOCK LENGTH IS  
37 9/16" LONG**

**LOOSEN CLAMP SCREWS  
USING A 12 POINT 10 mm SOCKET**

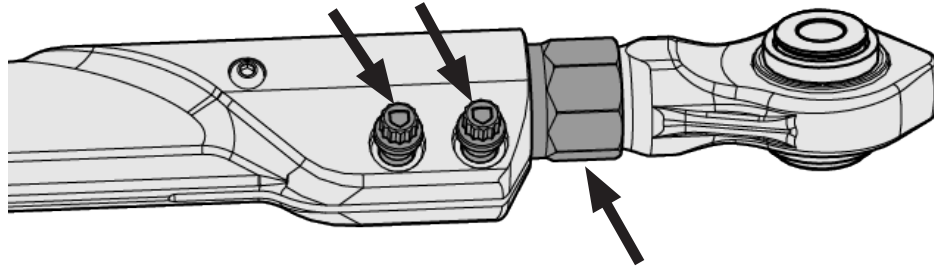

**USING A 1 3/8" WRENCH,  
ADJUST LENGTH BY  
TURNING THE SLEEVE**

**1**

**REMOVE THE REAR TRACK BAR**

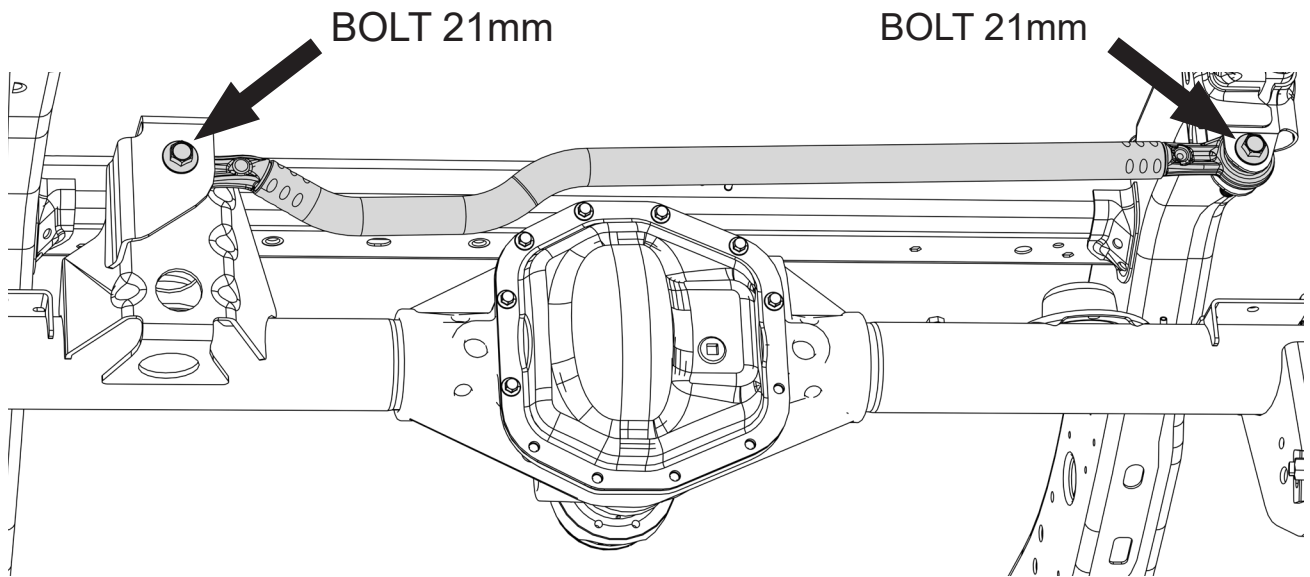

**2**

## INSTALL THE NEW REAR TRACK BAR

REUSE THE FACTORY HARDWARE TO INSTALL NEW TRACK BAR

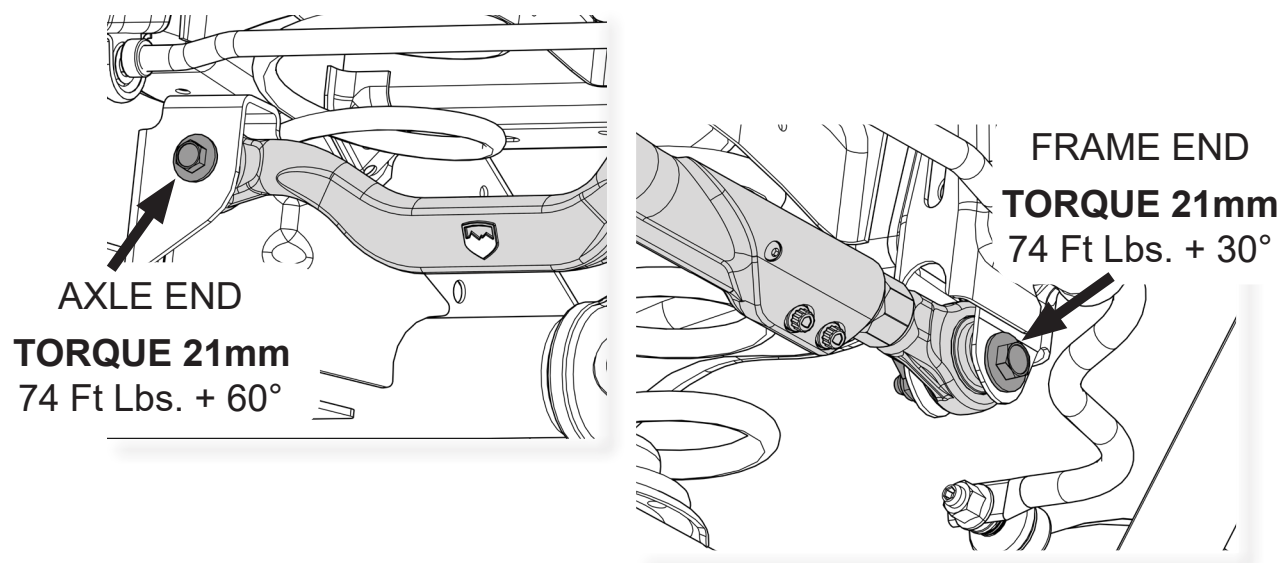

3

VERIFY THAT THE AXLE IS CENTERED UNDER THE JEEP  
AND ADJUST AS NEEDED

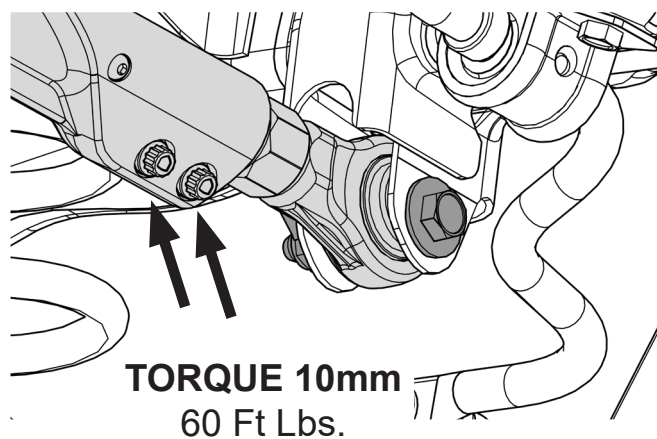

ONCE THE AXLE IS CENTERED UNDER THE JEEP  
TIGHTEN THE CLAMP SCREWS.

4