

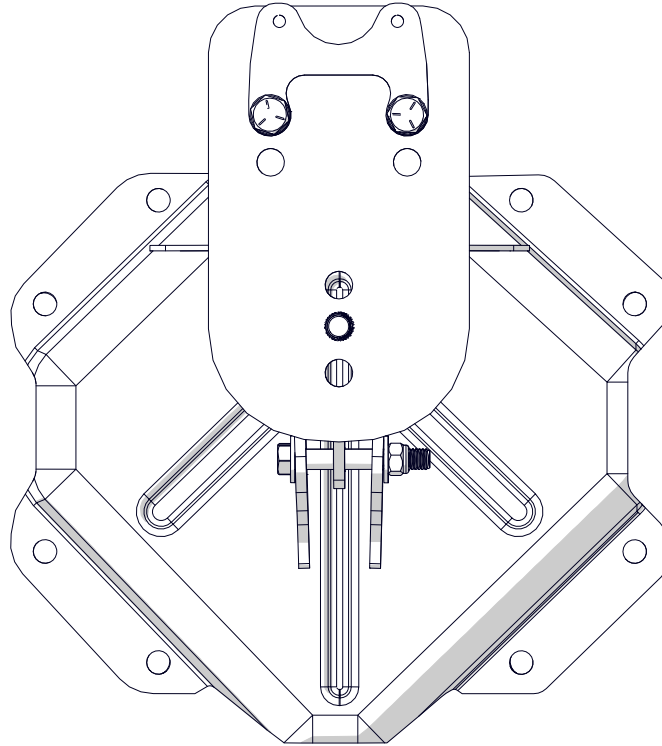

JK HD ADJUSTABLE SPARE TIRE MOUNTING KIT

#4838130

#4838135



Important Notes:

Prior to beginning this or any installation read these instructions to familiarize yourself with the required steps and evaluate if you are experienced and capable to personally perform these modifications. A factory service manual should be used in conjunction with these installation instructions.

Refer to the parts list to ensure that all necessary components and hardware has been included.

If you are using the factory wheels, you will also need to use a wheel spacer in conjunction with this kit. Kit #1055005.

Tools needed:

- Lug Wrench
- 13 mm socket
- 16 mm socket
- Ratchet
- Blue thread locking compound
- Cut off wheel and grinder or other method to cut factory third brake light

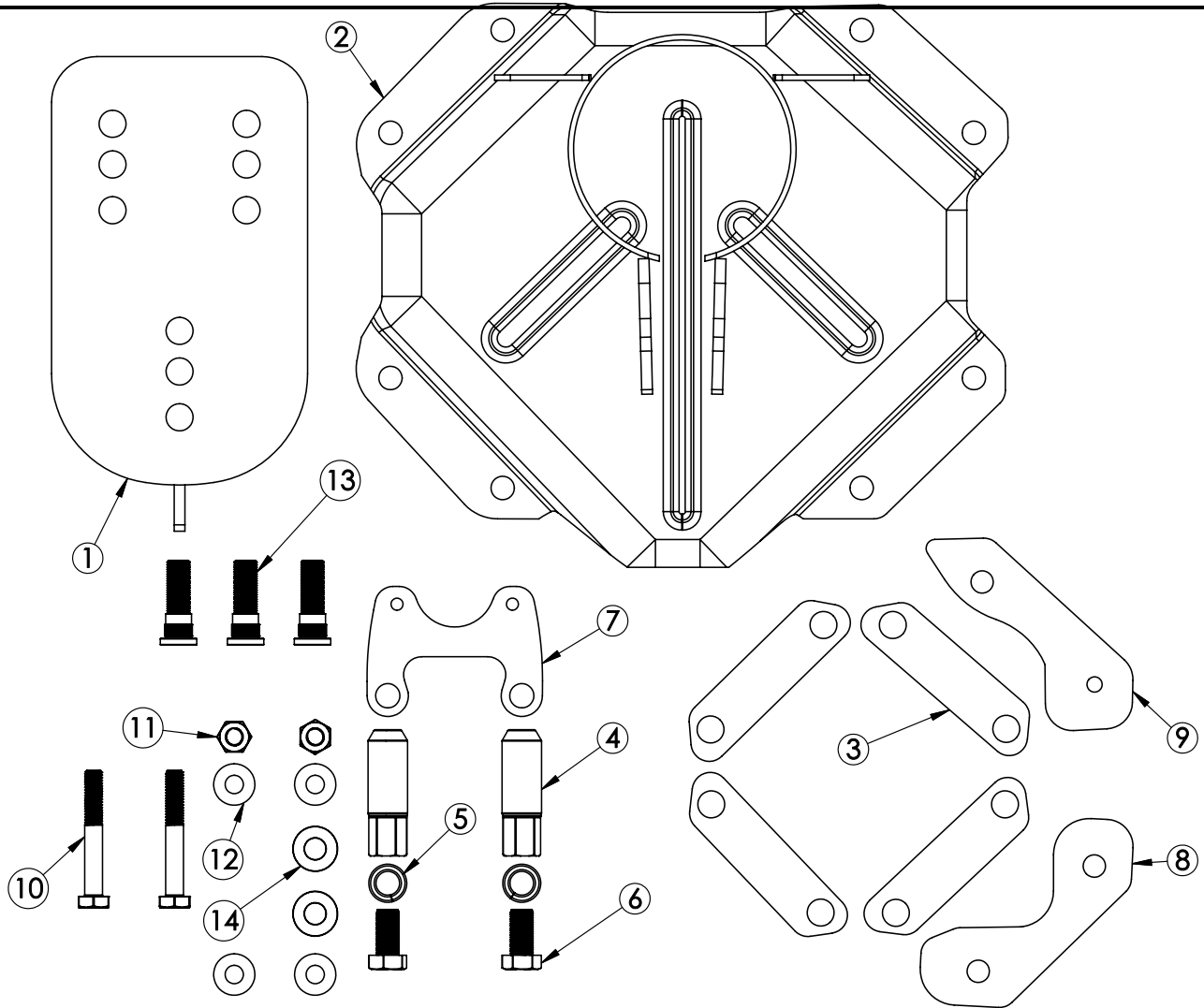

Call Out	Item Number	Description	4838130 Quantity	4838135 Quantity
1	838117	Adjustable Tire Mount Plate	1	1
2	838124	Adjustable Tire Mount Base	1	1
3	610039	Spacer Plate Gasket	4	4
4	838128	1/2"-20 Lug Nut	2	2
5	351	1/2" Split Lock Washer	2	2
6	235	1/2"-20 UNF x 1" Long Bolt	2	2
7	838149	High Mount Center Lamp Mounting Plate	1	1
8	838104	JK Spare Tire Carrier Lower Plate Spacer	1	-
9	838105	JK Spare Tire Carrier Upper Plate Spacer	1	-
10	252	M10 x 1.5 x 70mm Long Bolt	2	2
11	253	M10 x 1.5 Lock Nut	2	2
12	254	M10 Flat Washer	4	4
13	53007463	1/2"-20 x 1.7" Long Wheel Stud	3	3
14	838106	Adjustable Mount Anti-Rotation Spacer	2	2

The following instruction sheet details the installation of the HD Adjustable Spare Tire Mount on the tailgate as a stand alone tire mount, as well as in conjunction with the HD Hinged Carrier. Skip forward to step 10 if installing with the HD hinge kit.

Remove existing spare tire and original spare tire bumpers from tailgate, if present.

1

2

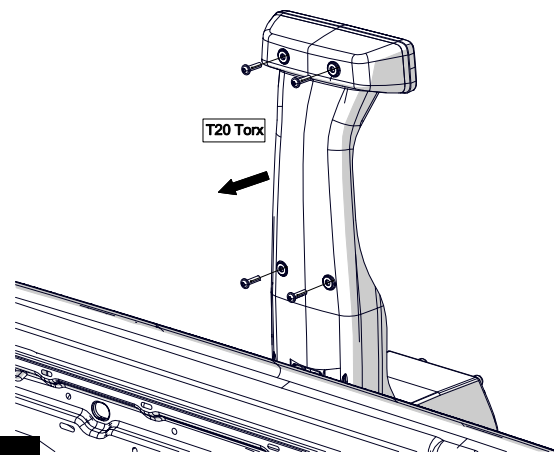

Unplug light connector

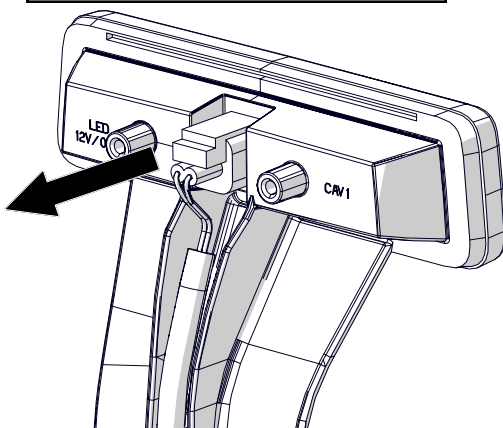

3

Remove tire mount

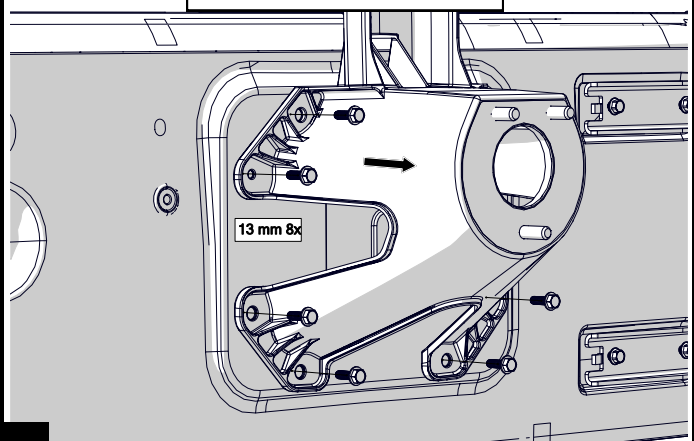

4

Place gaskets between tailgate and mount, apply thread locking compound and loosely install 4 of the original bolts

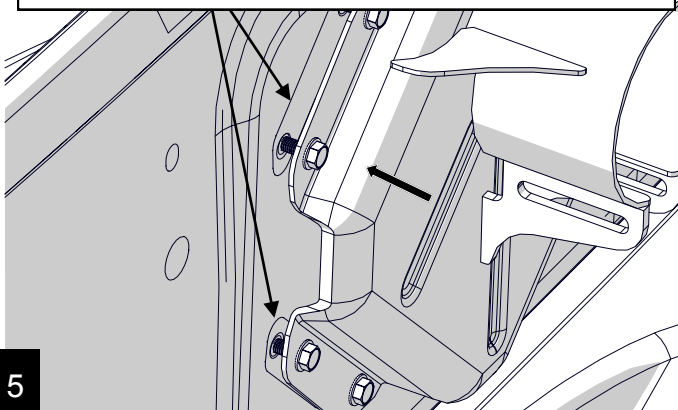

5

Orient spacers as illustrated



6

Place gaskets between tailgate and spacers, apply thread locking compound and loosely install remaining 4 original bolts

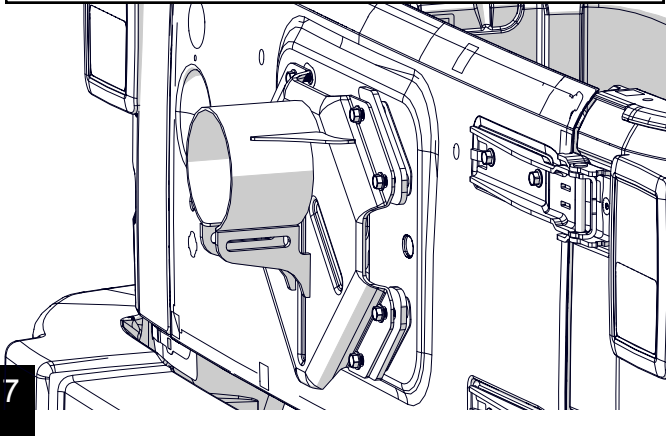

7

Torque the 8 mounting bolts to 15 ft-lbs (20 N-m)

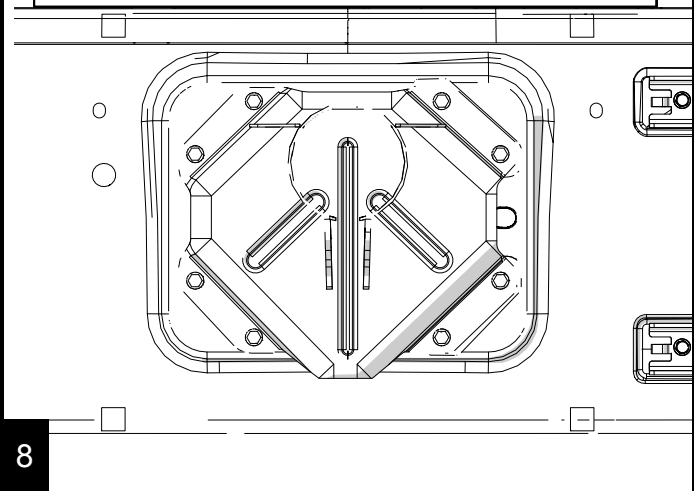

8

Steps 10-12 outline the installation of the adjustable tire mount base when installed in conjunction with the HD hinged carrier #4838100. Skip ahead to step 13 for tire mounting plate installation and adjustment.

9

Place gaskets between tailgate and mount, apply thread locking compound and loosely install 4 of the original bolts

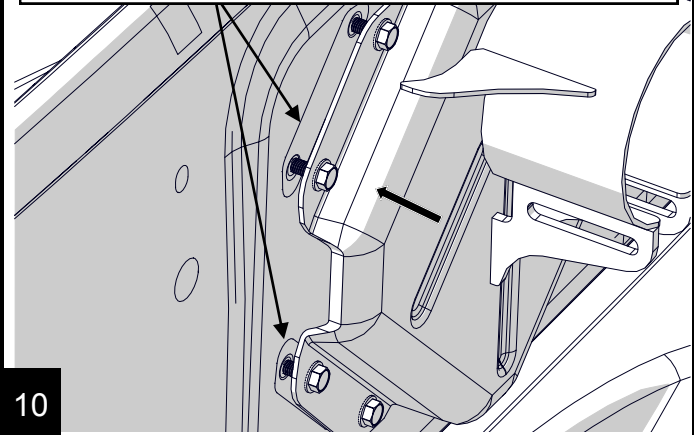

10

Place gaskets between cast hinge and mount, apply thread locking compound and loosely install remaining 4 original bolts

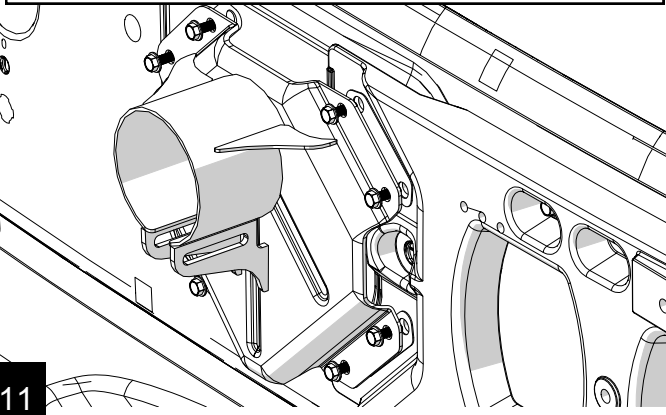

11

Torque the 8 mounting bolts to 15 ft-lbs (20 N-m)

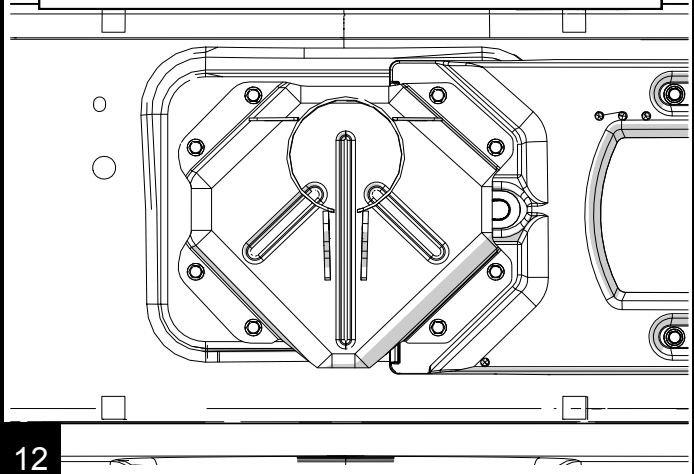

12

Press the included wheel studs into the appropriate set of holes for your tire size

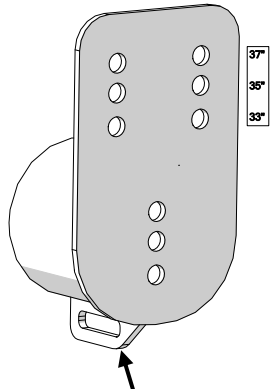

13

Check for wheel clearance here. If it hits, you will need a wheel spacer.

Attach the mount to the tire using 1 lug nut

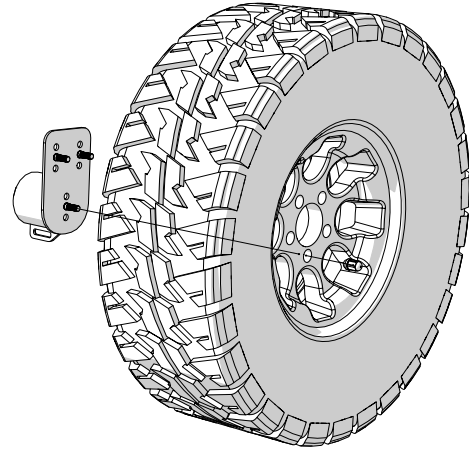

14

Slide the mount into the base on the tailgate, push the tire firmly up against the cast hinge

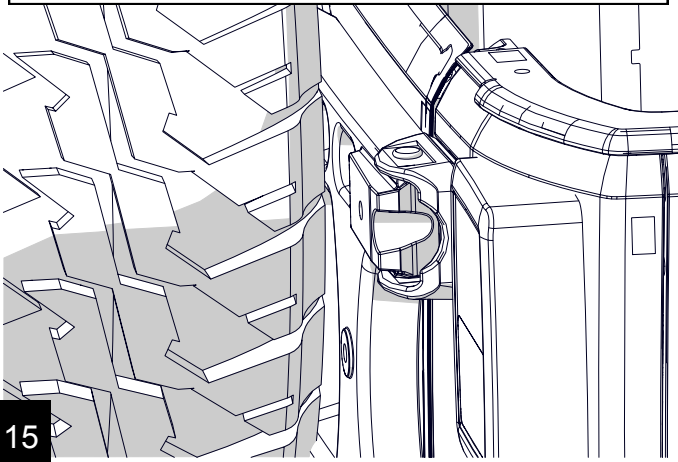

15

Mark a line on the mount where it meets the base, remove spare tire and mount assembly

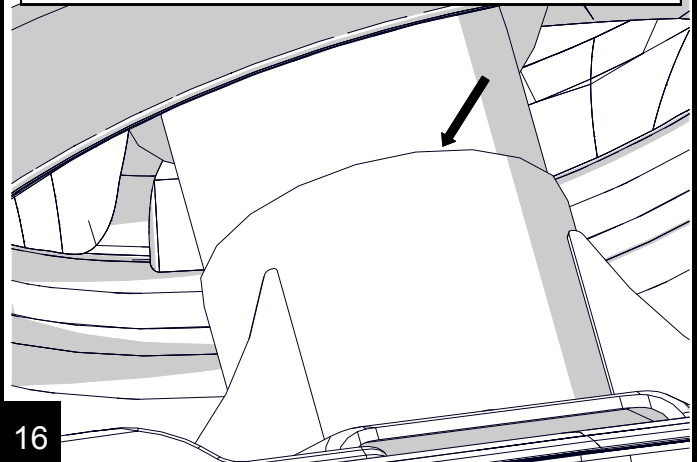

16

Remove the mount from the tire, using marked line as a reference, push mount in $1/8'' - 3/16''$ (3 - 4 mm) past line

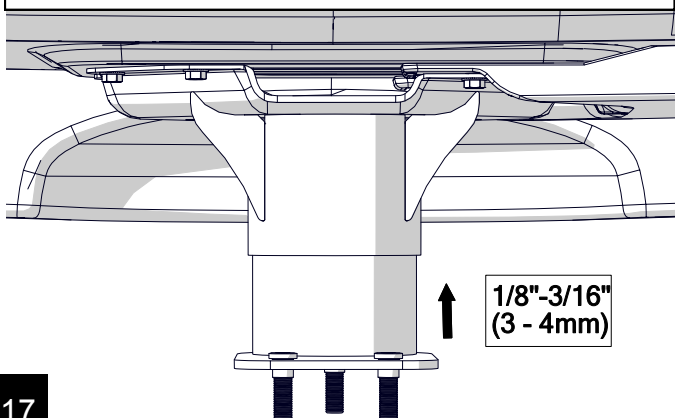

17

Install pinch bolts. Install the included spacers as shown to prevent the tire mount from rotating in the base. Ensure at least 1 bolt is installed through slot on mount. Torque bolts to 55 ft-lbs (75 N-m)

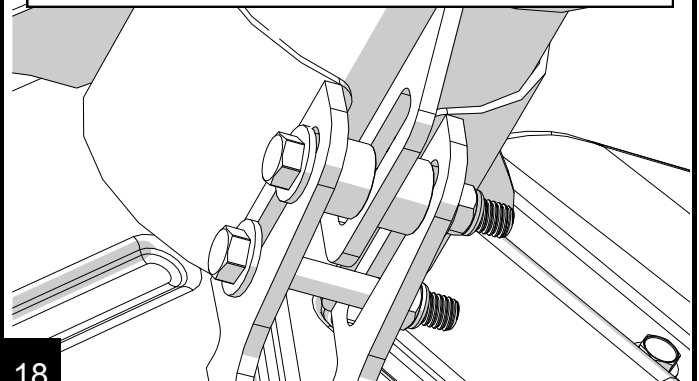

18

$1/8'' - 3/16''$
(3 - 4mm)

Cut factory third brake light along black line

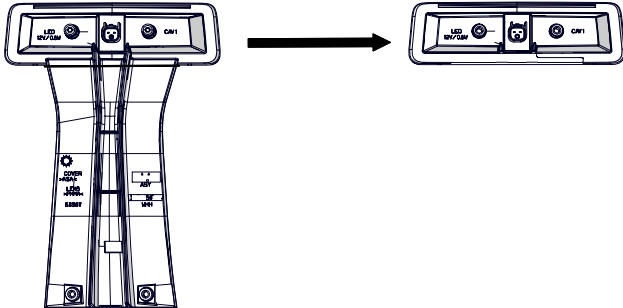

19

Use 2 original T20 Torx screws to mount the cut third brake light to bracket

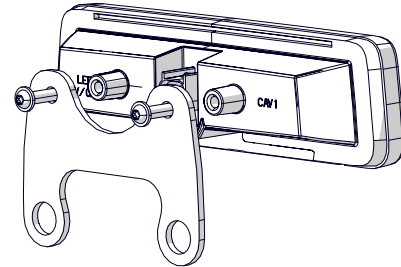

20

Install spare tire using the two lug nuts included in the kit and one original, torque to 65 ft-lbs (87 N-m)

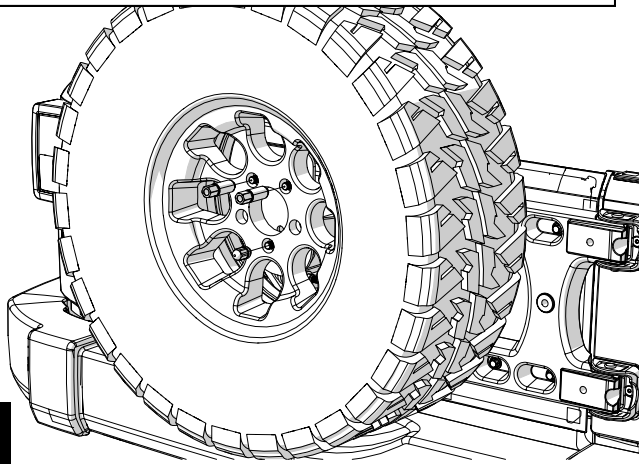

21

Route brake light wiring through wheel, plug light in and torque bolts to 37 ft-lbs (50 N-m)

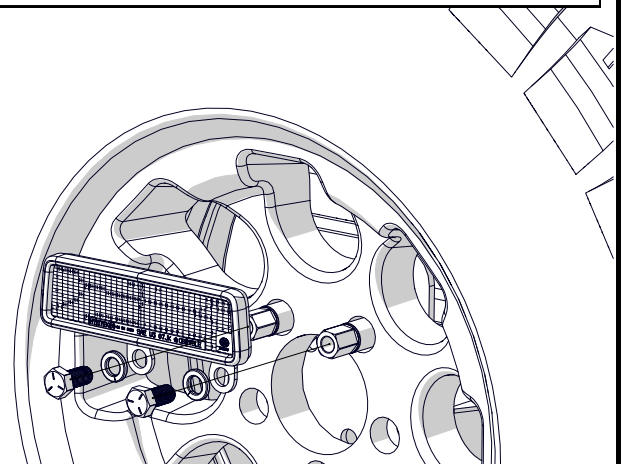

22

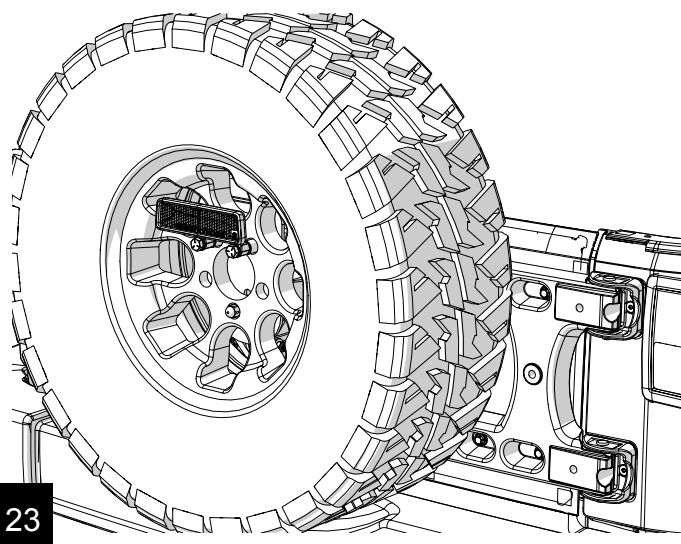

23

- Open and close tailgate to ensure proper function if cast hinge was installed.
- Ensure tire is **firmly** pressed against the cast hinge or against the factory tire bumpers on the tailgate if the cast hinge was not used

24

PRODUCT INFORMATION

MAINTENANCE INFORMATION:

It is the buyer's responsibility to have all suspension, drivetrain, steering, and other components checked for proper tightness and torque after the first 100 miles and every 3000 miles after that.

NOTICE TO INSTALLER:

The enclosed "Warning to Driver" sticker must be installed in the vehicle in driver's view. This sticker is to act as a constant safety reminder when operating the vehicle. It is your responsibility as the equipment installer to install the provided sticker and to forward the product instructions to the vehicle's owner for review. If a "Warning to Driver" sticker or product installation guide were not included in the kit, FREE replacement stickers and instructions are available by request. It is the installer's duty to ensure a safe and controllable vehicle after the modifications have been performed.

WARNING:

Neither the seller nor the manufacturer will be liable for any loss, damage, or injury directly or indirectly arising from the use of or inability to determine the use of these products. Before using, the user shall determine the suitability of the products for its intended use, and the user shall assume all responsibility and risk in connection therewith.

WARNING TO DRIVER:

This vehicle has been modified to enhance off road performance and has unique handling characteristics. Use in harsh environments can cause extreme stress on the components. Vehicle should be inspected after being off road to make sure that all the components are in working order and safe to travel on the highway. All fasteners should be checked so that they are at the correct torque specifications as the vibration and stresses from off roading may cause critical fasteners to work loose. Extra care should be taken to inspect the critical components, steering, and brake systems. During each oil change components such as arms, tie rod ends, etc should be greased and checked for excessive wear. Any worn components should be replaced. When returning to the pavement always set or restore tire air pressure to the factory recommendation and connect or engage any disabled sway bar mechanisms. Because of the higher center of gravity and larger tires, this vehicle handles and reacts differently than many passenger cars, both on and off road. You must drive it safely! Extreme care should be taken to prevent vehicle rollover or loss of control, which can result in serious injury or death. Avoid sudden sharp turns or abrupt maneuvers. Generally, braking performance and capabilities are decreased when significantly larger/heavier tires are used, especially when used in combination with transfer case low-range reduction kits. Take this into consideration while driving. Do not add, alter or fabricate any factory or aftermarket parts to increase vehicle height over the intended height of the TeraFlex product purchased. Mixing component brand is not recommended. TeraFlex Inc. will not be responsible for any altered product or any improper installation or use of our products. We will be happy to answer any questions concerning the design, function, and correct use of our products. It is ultimately the buyer's responsibility to have all bolts/nuts checked for tightness after the first 100 miles and then every 3000 miles. Wheel alignment, steering system, suspension and drive line systems must be inspected by a qualified professional mechanic at least every 3000 miles.