

➤ Instructions

Thule ReVert 6 Bike



9026500



**EN**

IMPORTANT - READ THE INSTRUCTIONS CAREFULLY BEFORE USE AND KEEP FOR FUTURE REFERENCE.



Symbols

-  **WARNING** indicates a hazardous situation which, if not avoided, could result in death or serious injury.
-  **CAUTION** indicates a hazardous situation which, if not avoided, could result in minor or moderate injury.
-  **Note** indicates additional information that is useful for trouble-free and optimal use of the product.

ES

IMPORTANTE - LEER LAS INSTRUCCIONES CUIDADOSAMENTE ANTES DEL USAR Y CONSÉRVELAS PARA FUTURA REFERENCIA.



Símbolos

-  **ADVERTENCIA** indica una situación de posible peligro que, si no se evita, podría provocar lesiones graves o incluso la muerte.
-  **ATENCIÓN** indica una situación peligrosa que, si no se evita, podría provocar lesiones leves o moderadas.
-  **NOTA** indica información adicional que es útil para un uso óptimo y sin problemas del producto.

FR

IMPORTANT - LISEZ ATTENTIVEMENT LES INSTRUCTIONS AVANT UTILISATION ET CONSERVEZ-LES POUR RÉFÉRENCE FUTURE.



Symboles

-  **AVERTISSEMENT** indique une situation potentiellement dangereuse qui, si elle n'est pas évitée, pourrait provoquer des blessures graves, voire mortelles.
-  **ATTENTION** indique une situation potentiellement dangereuse susceptible qui, si elle n'est pas évitée, peut entraîner des blessures mineures ou modérées.
-  **REMARQUE** indique comment répondre à une situation donnée et vous donnent des conseils sur le fonctionnement des options disponibles.

PT

IMPORTANTE - LER CUIDADOSAMENTE AS INSTRUÇÕES ANTES DE USAR E GUARDÁ-LAS PARA FUTURA REFERÊNCIA.

Símbolos

-  **ATENÇÃO** indica uma situação perigosa que, se não for evitada, pode resultar em morte ou ferimentos graves.
-  **CUIDADO** indica uma situação perigosa que, se não for evitada, pode resultar em ferimentos ligeiros ou moderados.
-  **NOTA** indica informações adicionais que são úteis para a utilização ideal e sem problemas do produto.

**EN****FR****ES****PT**

Motorized RV* travel at 60% load capacity (i.e., 40% total load reduction) when mounted on van conversions or motorized RV vehicles with an overhang exceeding 230 cm (7.5 ft), measured from the center of the rear wheel to the most distant rear point of the vehicle.

Les voyages en VR motorisés* se font à 60 % de la capacité de charge (c'est-à-dire, une réduction de 40 % de la charge totale) lorsqu'ils sont montés sur des conversions de fourgon ou des véhicules VR motorisés avec un surplomb dépassant 230 cm (7,5 pieds), mesuré depuis le centre de la roue arrière jusqu'au point arrière le plus éloigné du véhicule.

Los viajes en vehículos recreativos motorizados* se realizan al 60 % de la capacidad de carga (es decir, una reducción del 40 % de la carga total) cuando se montan en conversiones de furgonetas o vehículos recreativos motorizados con un voladizo que excede los 230 cm (7,5 pies), medido desde el centro de la rueda trasera hasta el punto trasero más distante del vehículo.

Viagens em veículos recreativos motorizados* devem ser realizadas com 60% da capacidade de carga (ou seja, uma redução de 40% da carga total) quando montados em conversões de vans ou veículos recreativos motorizados com um balanço que exceda 230 cm (7,5 pés), medido a partir do centro da roda traseira até o ponto traseiro mais distante do veículo.

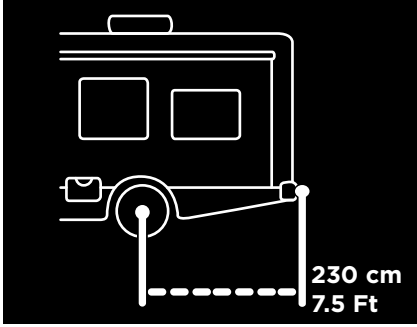

WARNING!

This carrier is not compatible with travel trailers/caravans, 5th wheels or any bumper mounted hitch receiver.

* Refer to definition 49 CFR 571.3 (c) "Motor home", National Highway Traffic Safety Administration, Department of Transportation.

AVERTISSEMENT!

Ce porte-vélos n'est pas compatible avec les caravanes de voyage, les caravanes à sellette ou tout récepteurs d'attelage de pare-chocs.

* Veuillez vous référer à la définition 49 CFR 571.3 (c) "motor home", national highway traffic safety administration, department of transportation.

ADVERTENCIA!

Este portabicicletas no es compatible con remolques de viaje/caravanas, casas rodantes de quinta rueda ni con ningún enganche montado en el parachoques.

* Consulte la definición 49 CFR 571.3 (c) "motor home", national highway traffic safety administration, departamento de transporte.

ATENÇÃO!

Este suporte não é compatível com reboques/caravanas de viagem, reboques de quinta roda ou com qualquer engate montado no para-choque. Armente como está a fixação da carga.

* Consulte a definição 49 CFR 571.3 (c) "Motor home", National Highway Traffic Safety Administration, Departamento de Transporte.

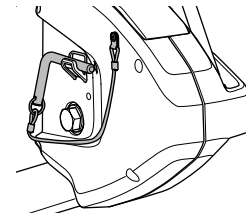
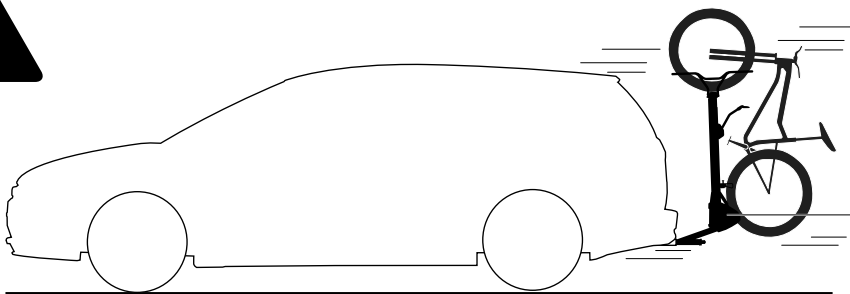
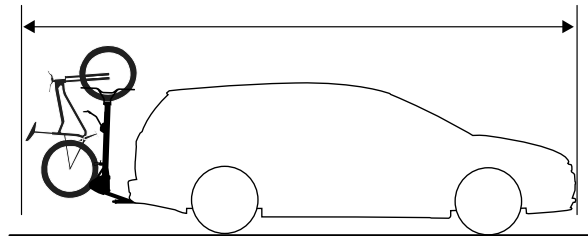
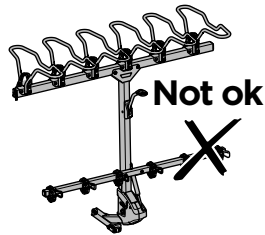
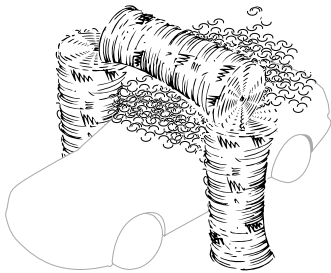

Not ok
X

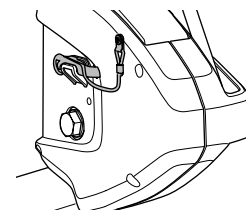
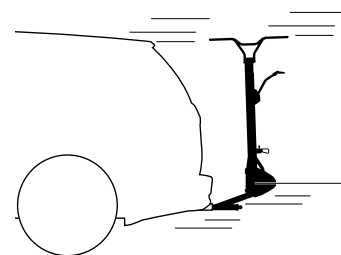
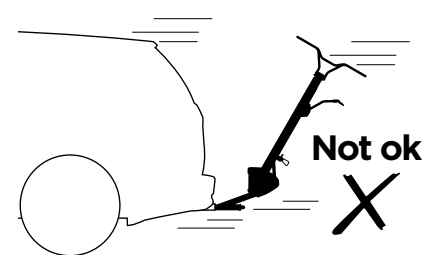

ok
✓

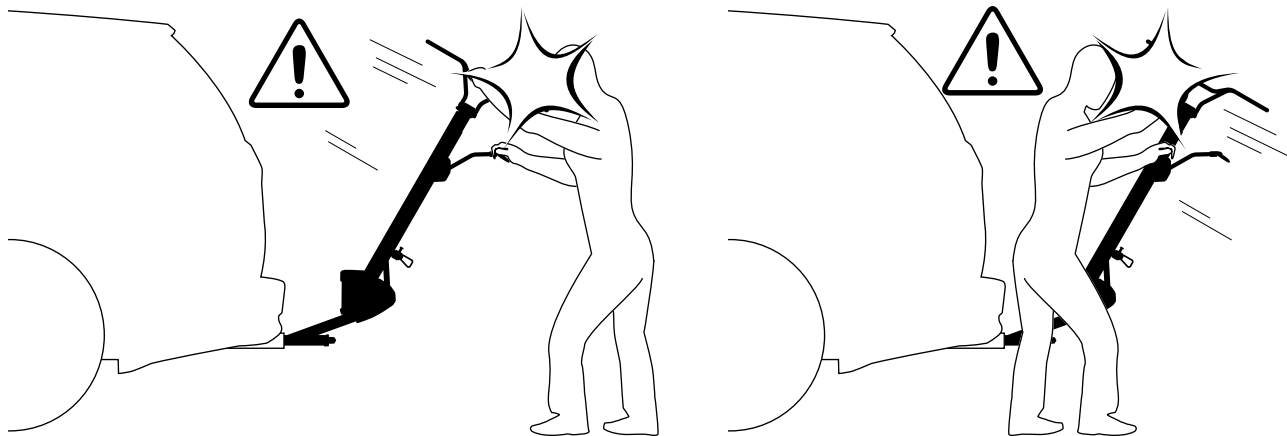

87 lbs.
(39.5 kg)

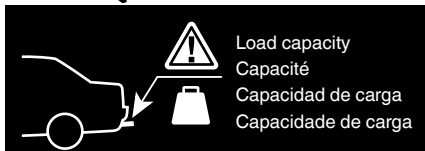

Max 55 lbs.
(25 kg)

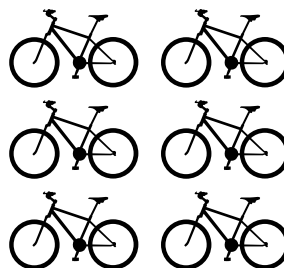

Max 250 lbs.
(113 kg)



ok
✓



Not ok
✗



Not ok
✗

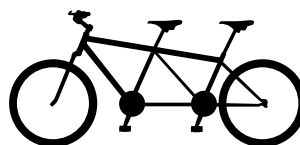

Not ok
✗



Not ok
✗

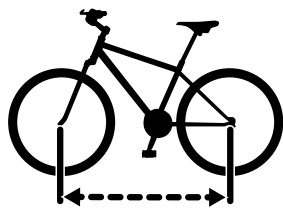

53" max
wheelbase



25" min and 29" max

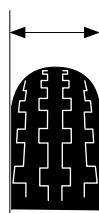

1" - 3" max

Thule ReVert Child
Bike Adapter
9020530



20" min and 24" max

Thule ReVert
Fatbike Adapter
9020540

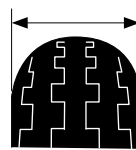

3" - 5" max

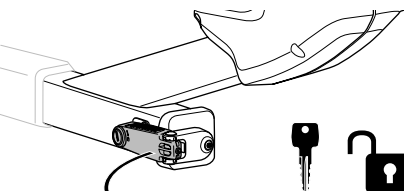

300 miles
500 km

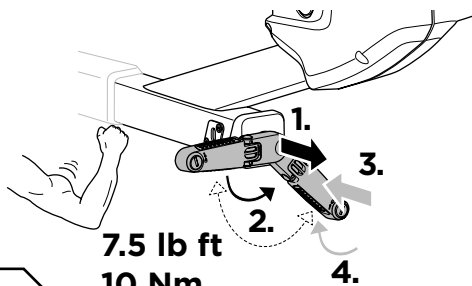

7.5 lb ft
10 Nm

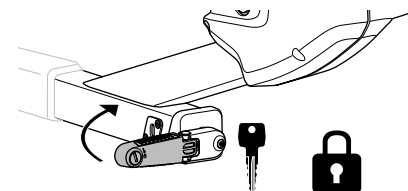

i

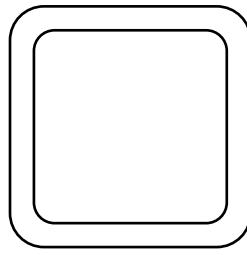
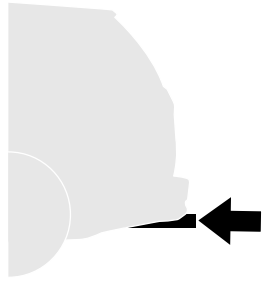

2"
51 mm

1

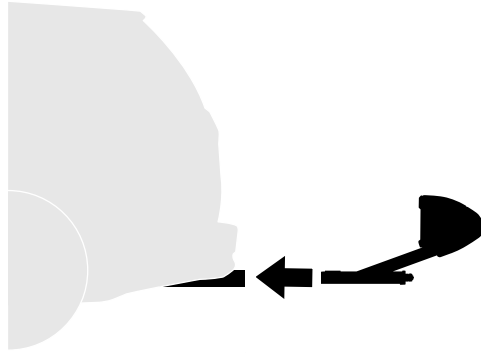

A

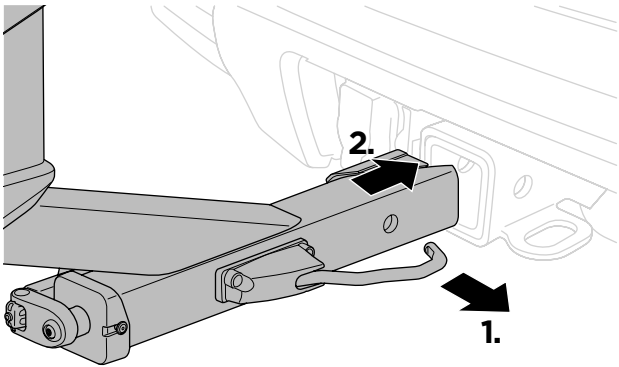

B

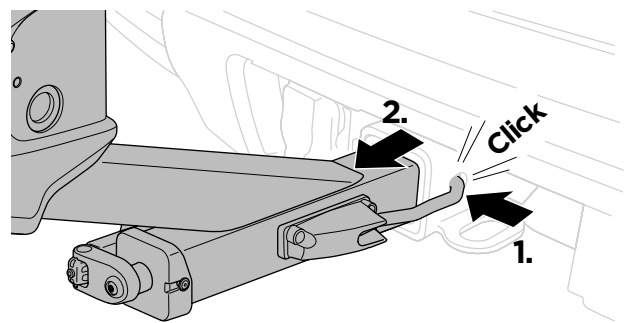

2

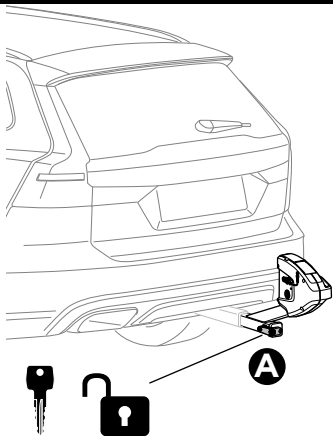

B

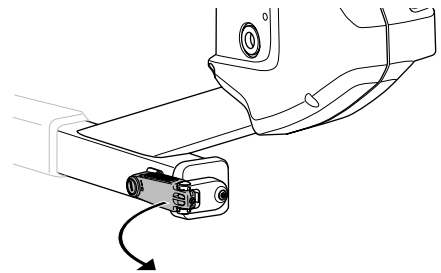

C

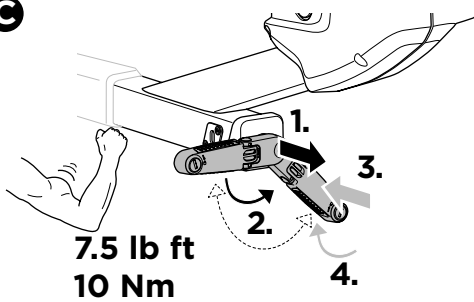

D

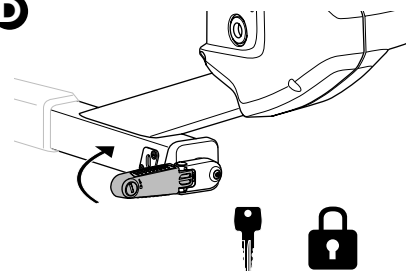

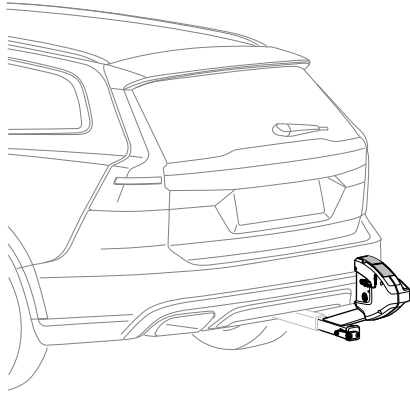

A

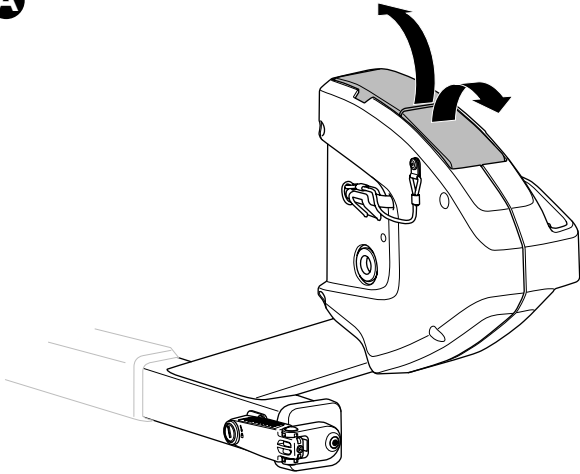

B

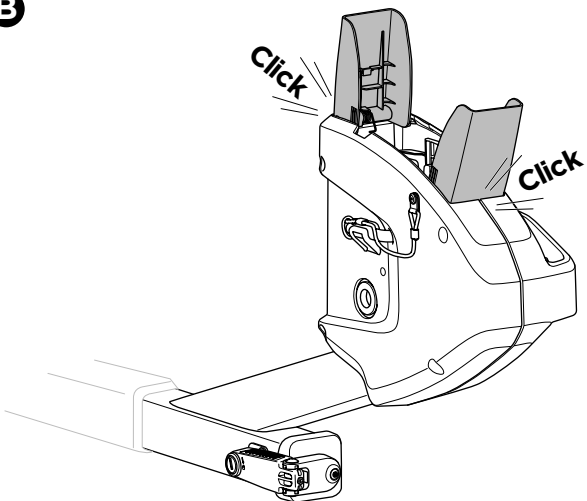

C

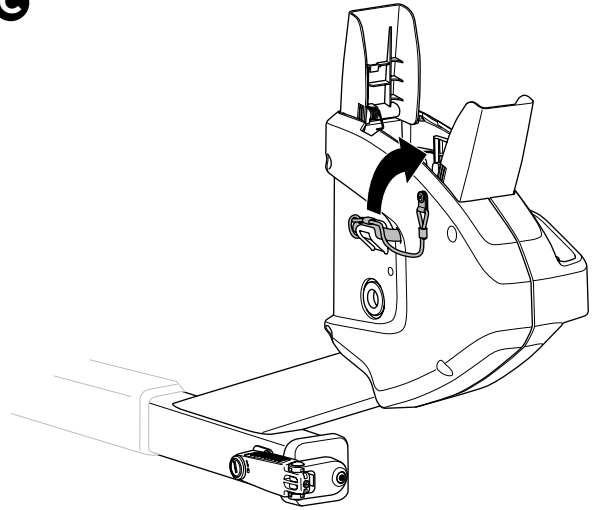

D

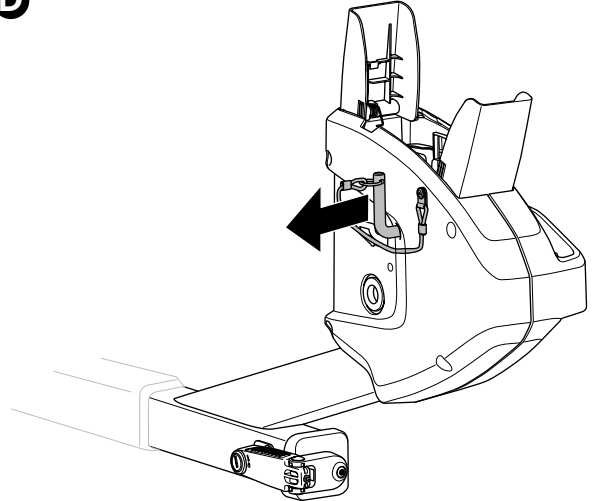

E

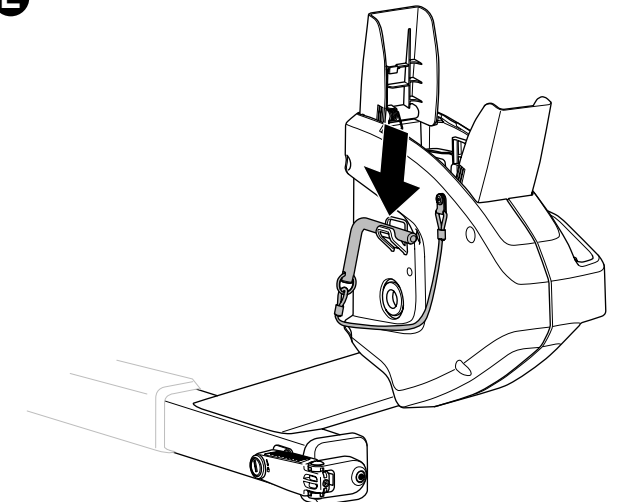

4

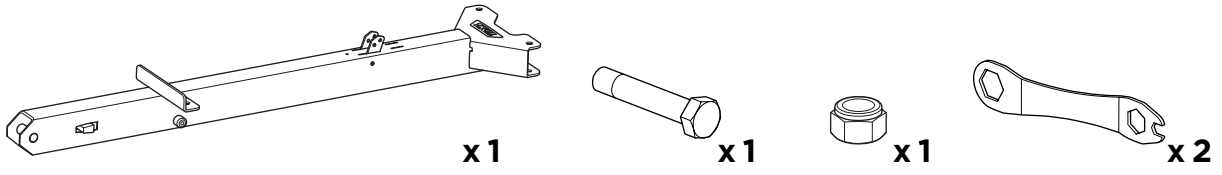

A

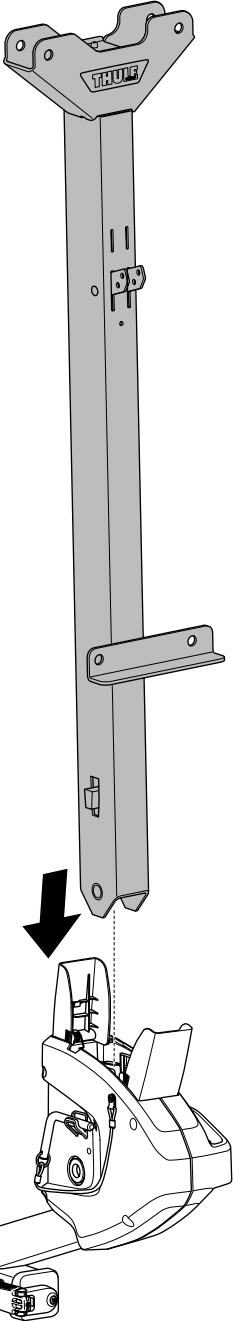

B

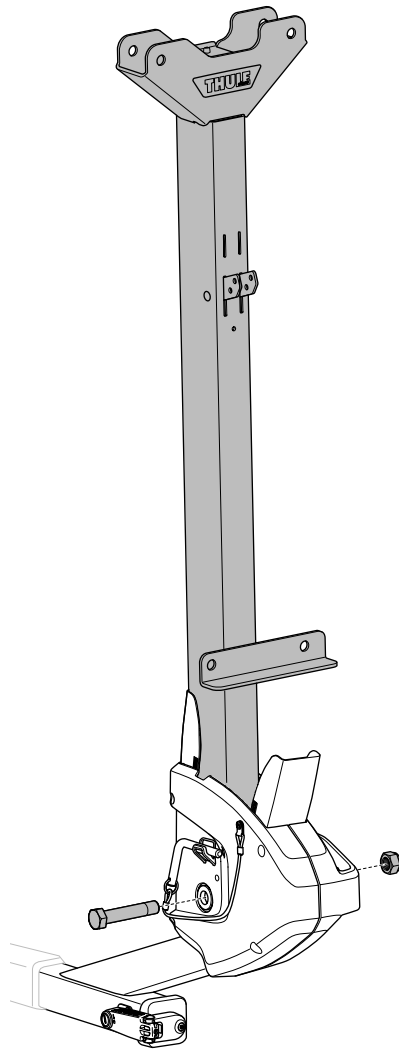

C

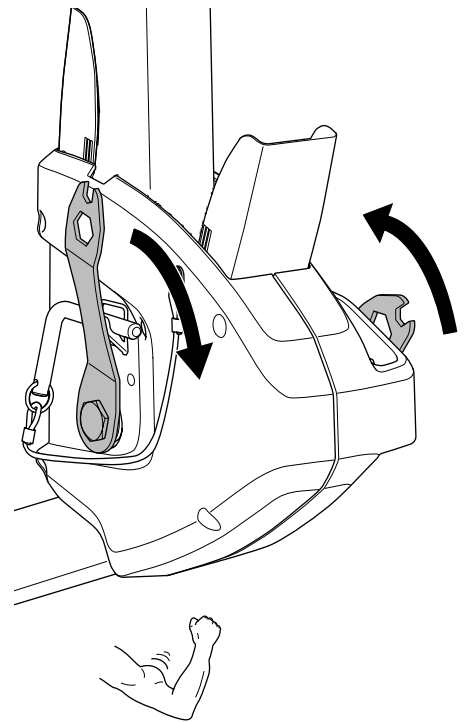

22.13 lb ft
30 Nm

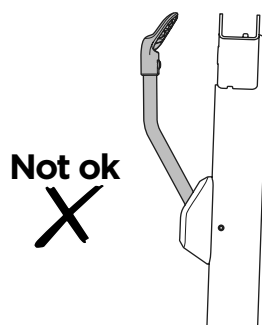
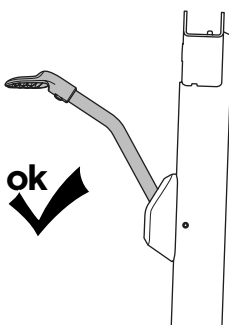
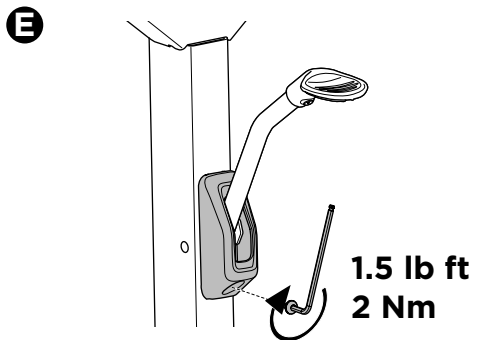
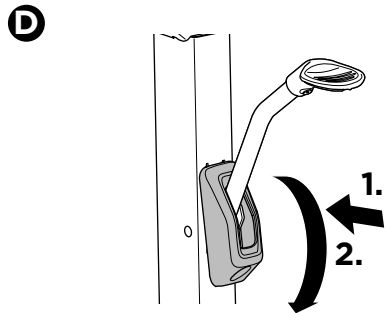
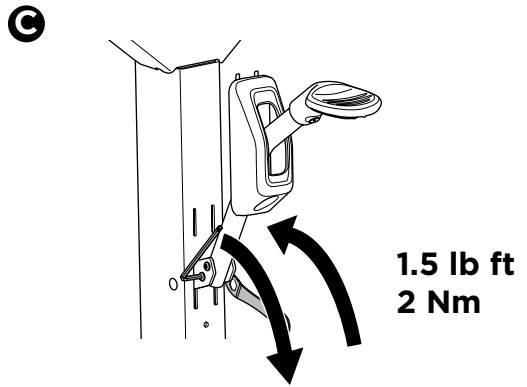
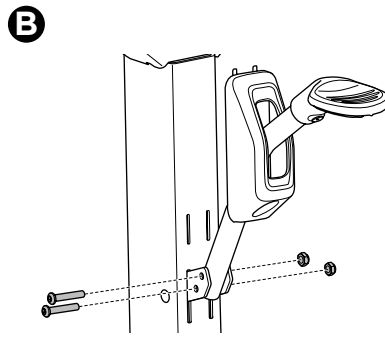
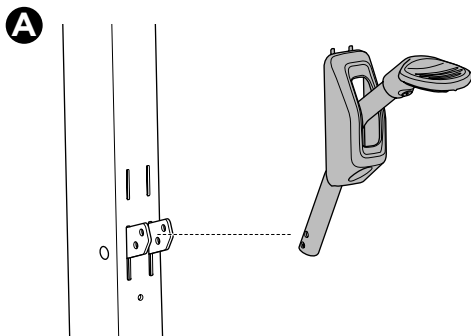
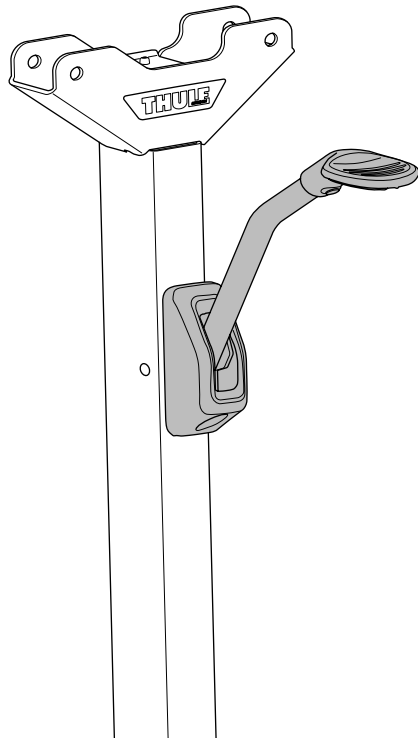
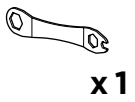
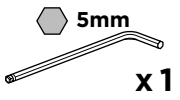
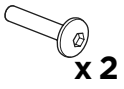
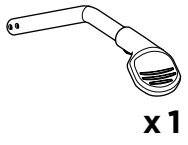
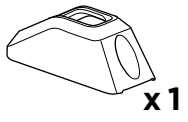

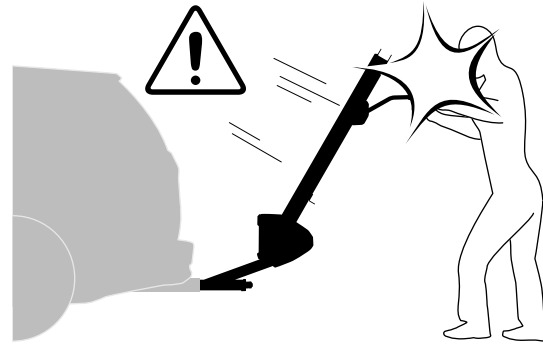

6

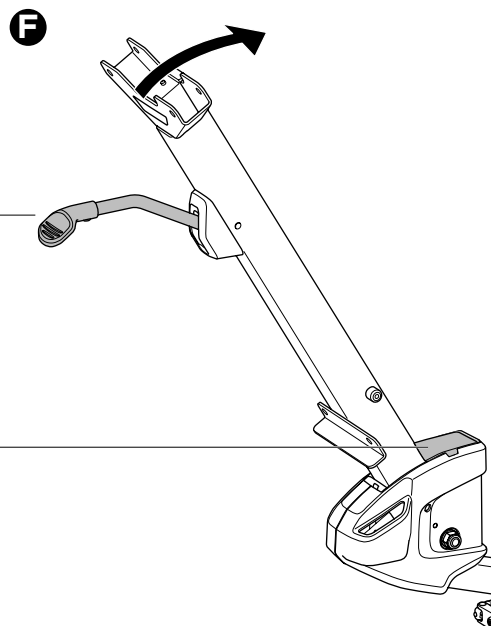
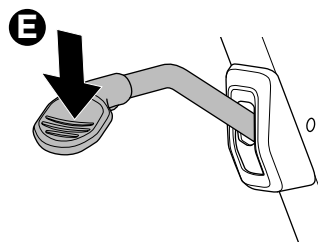
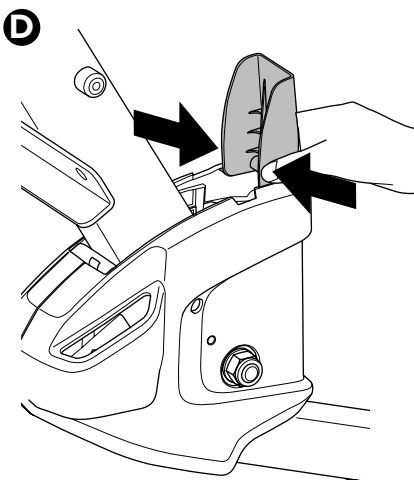
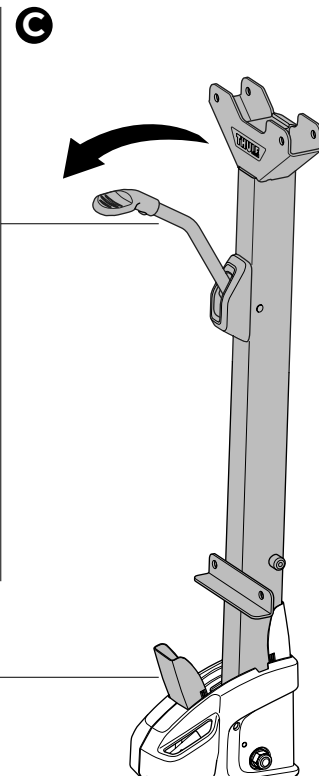
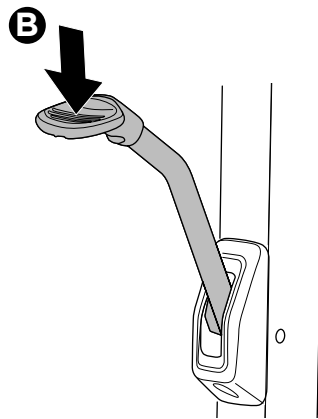
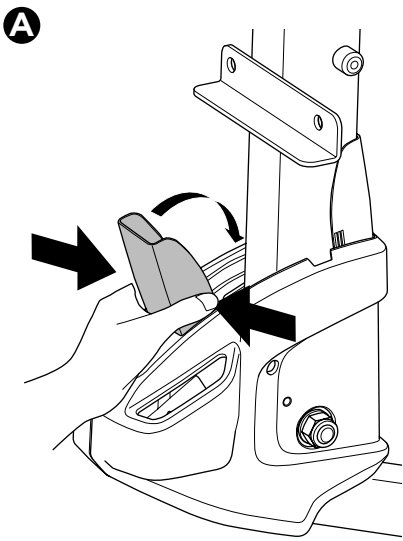

7

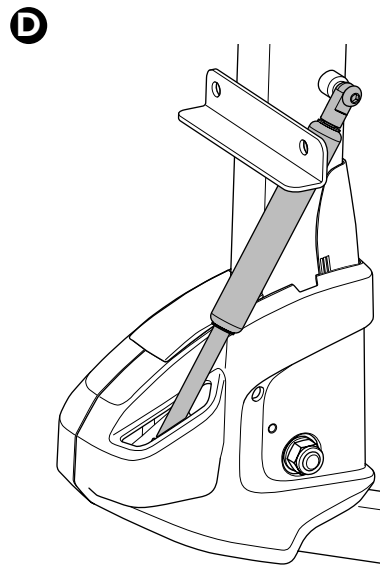
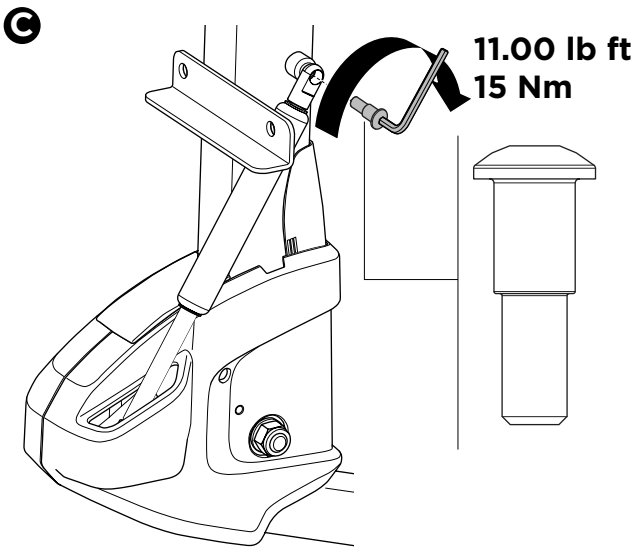
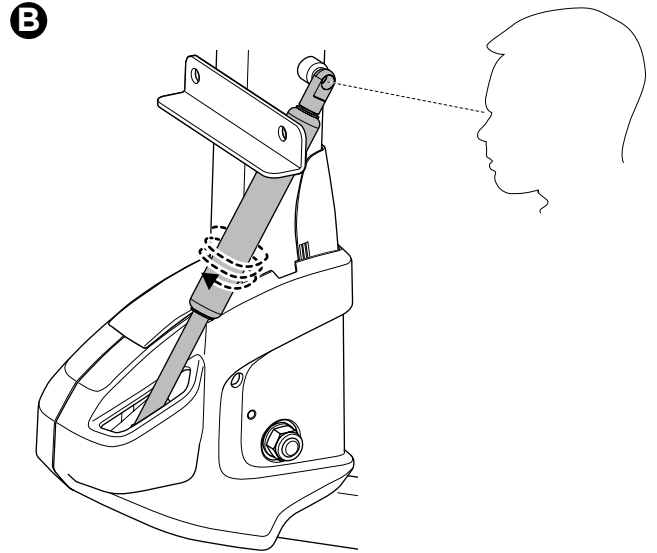
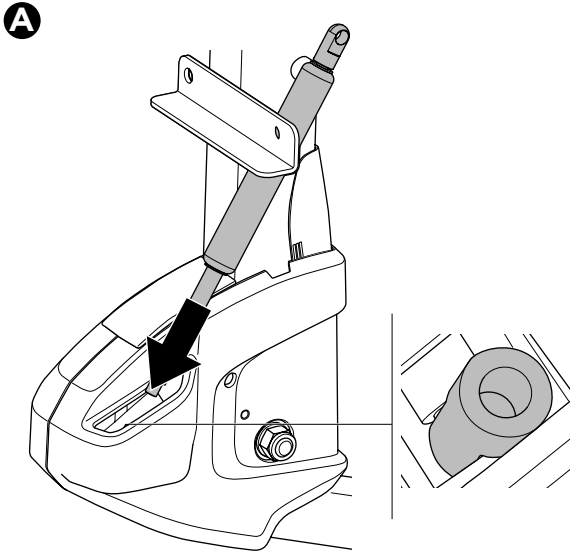
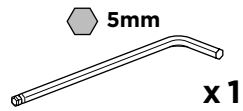
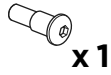
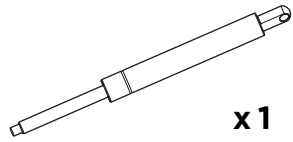

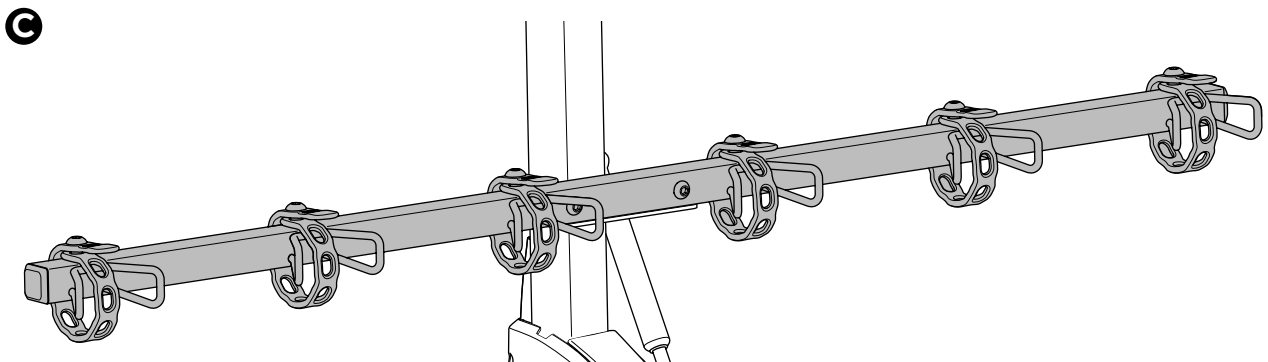
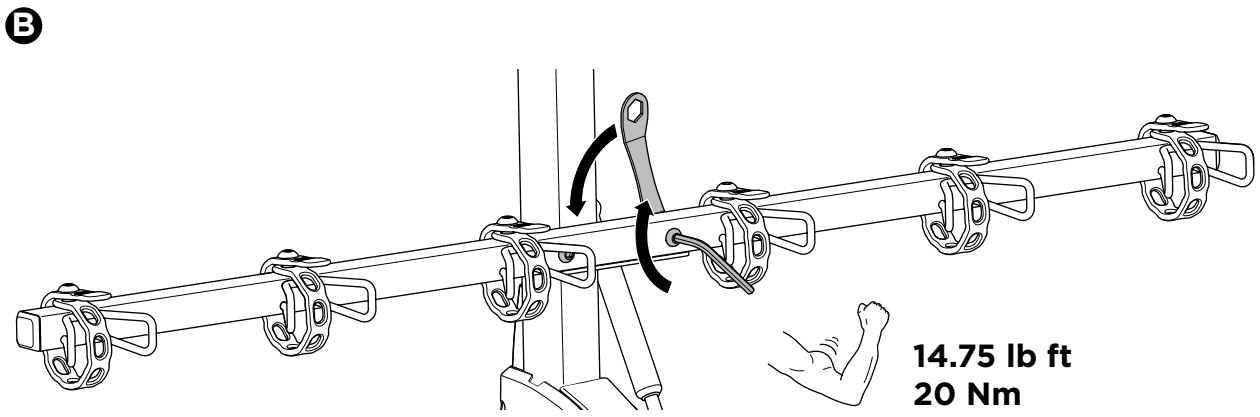
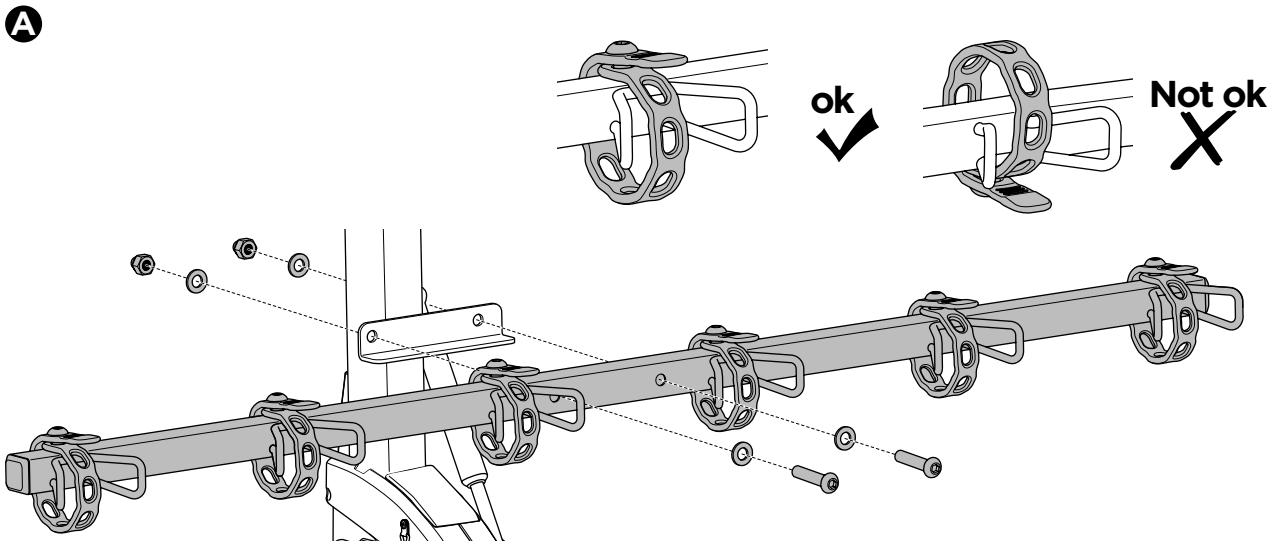
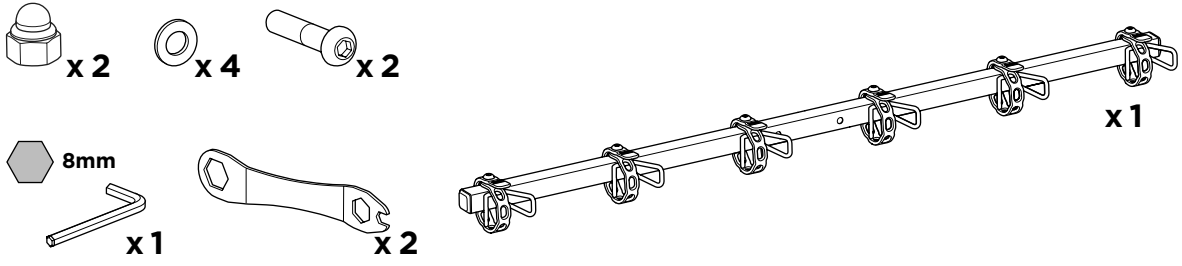

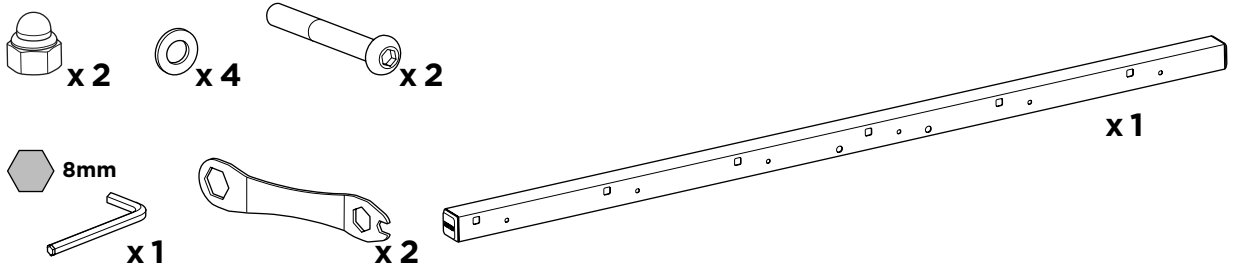

A

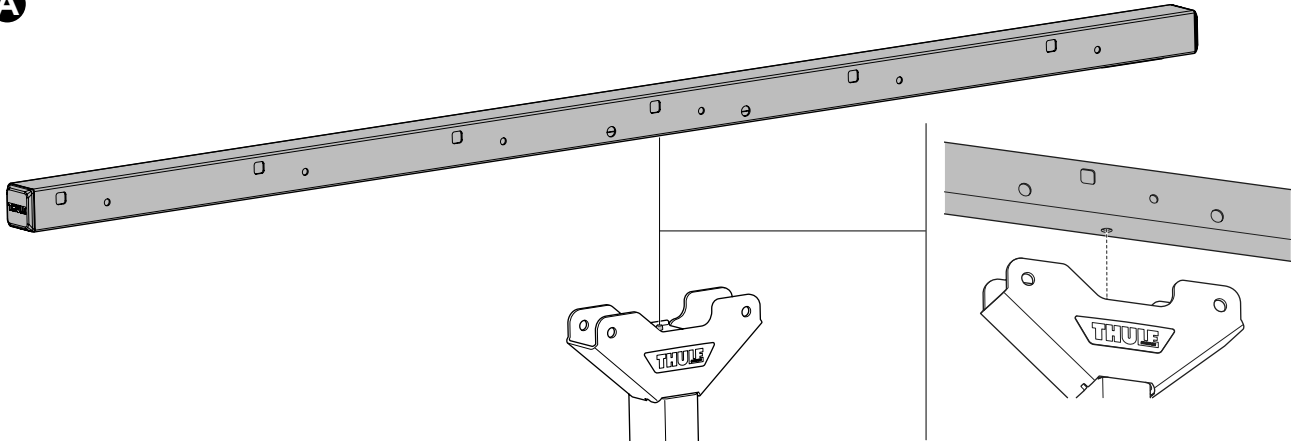

B

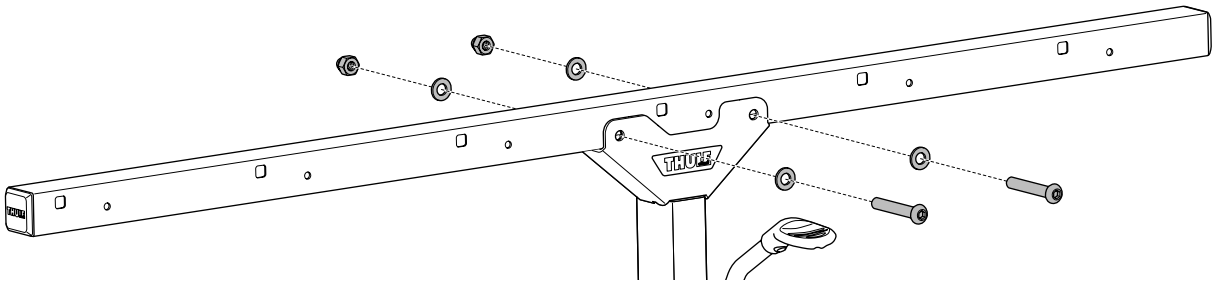

C

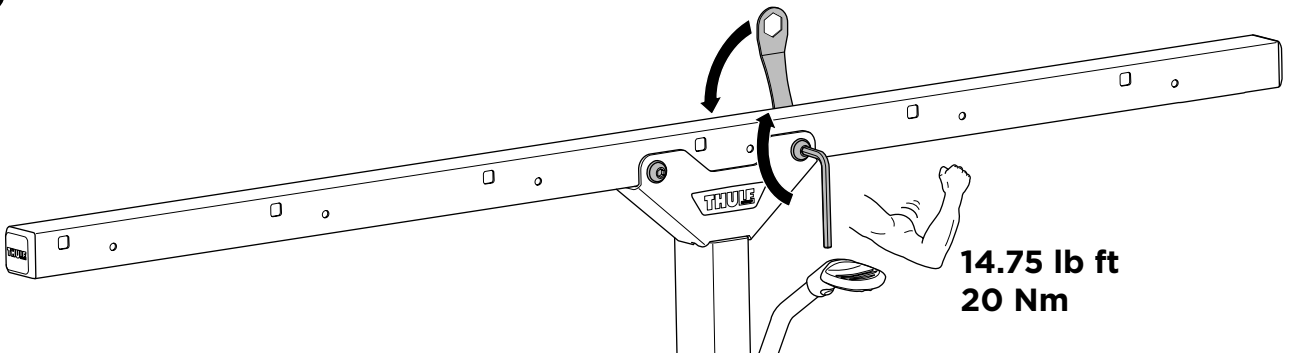

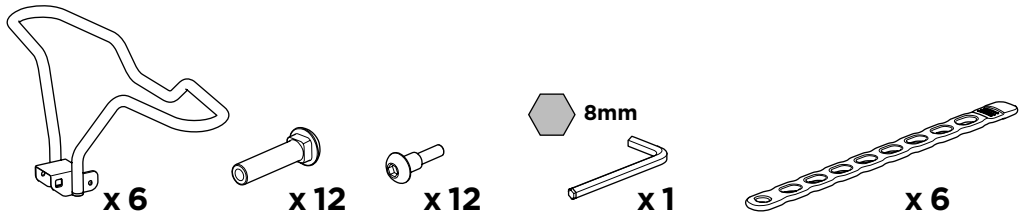

A

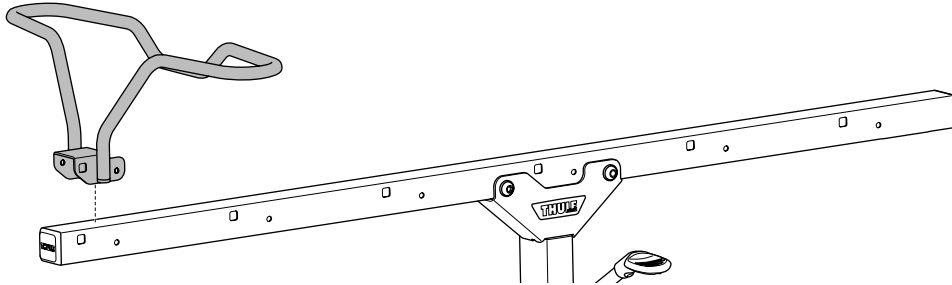

B

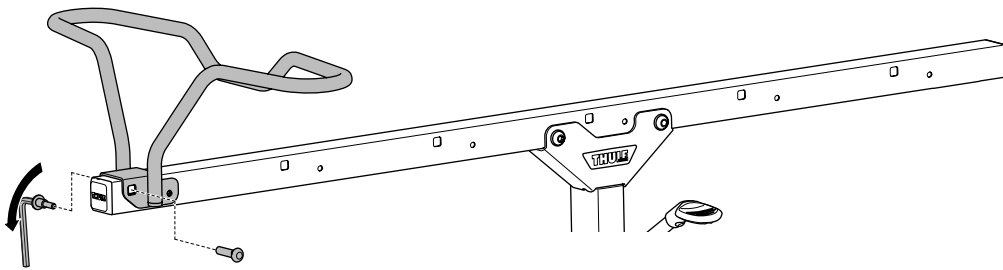

C

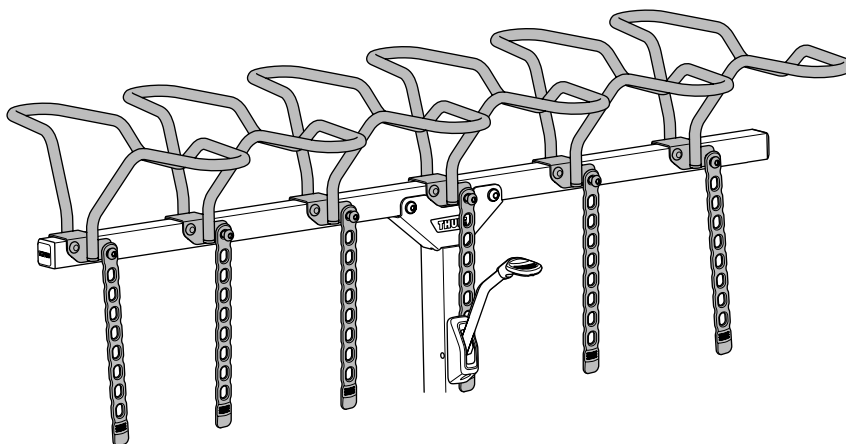
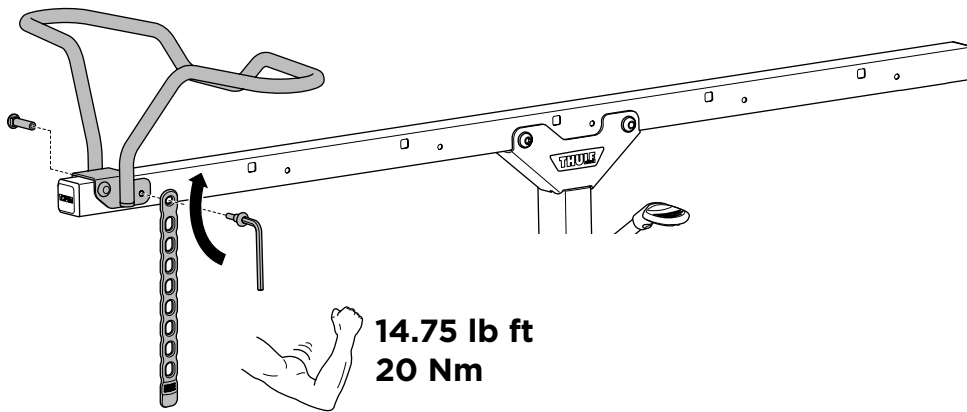

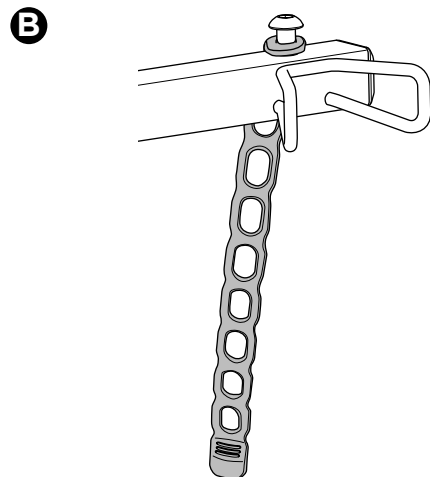
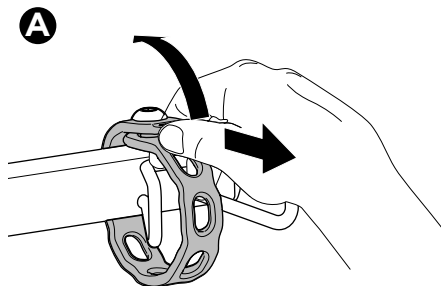
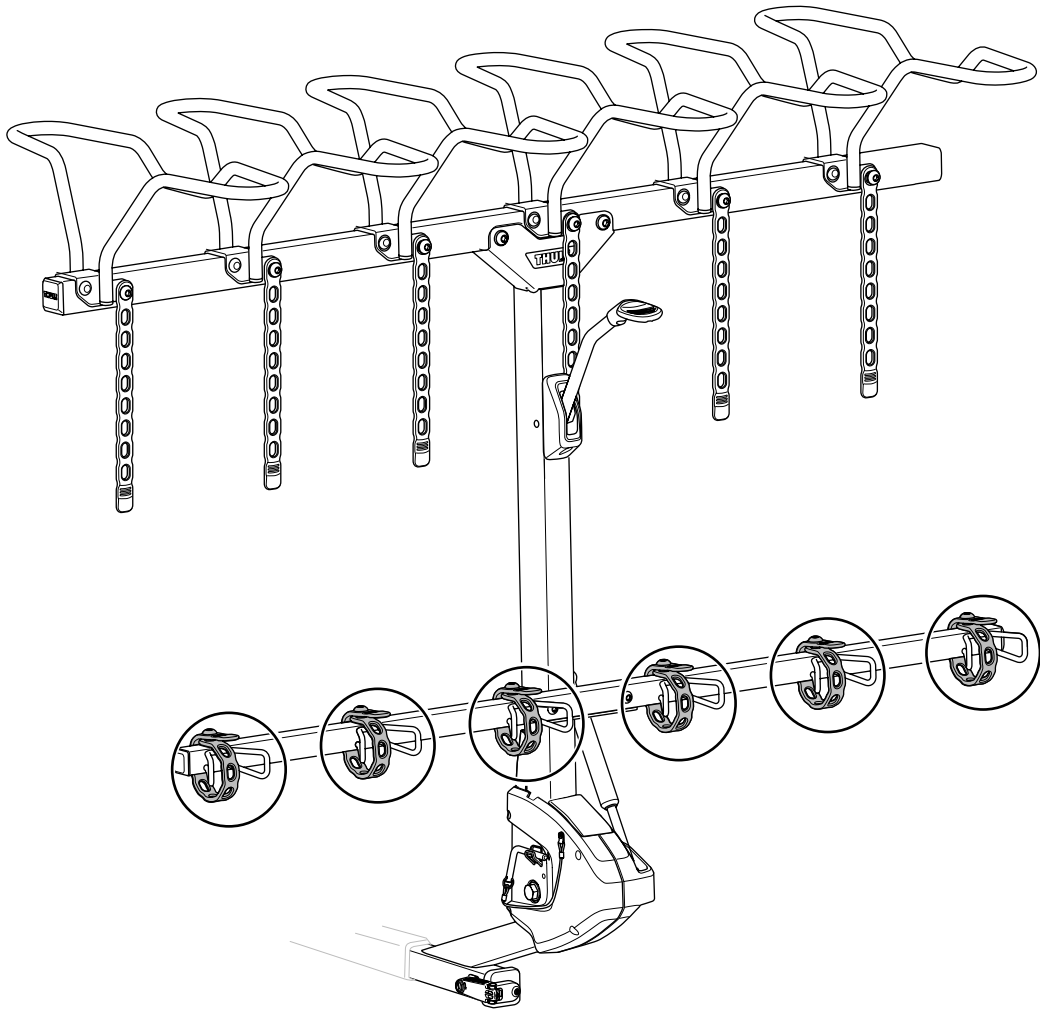

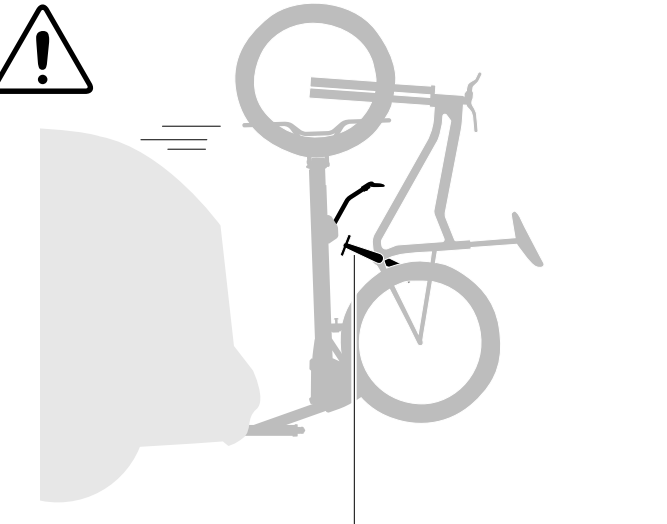
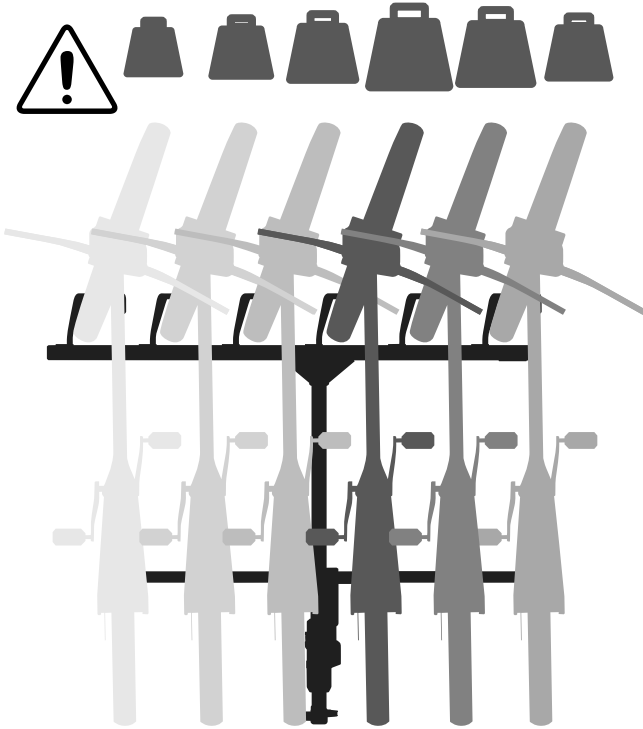
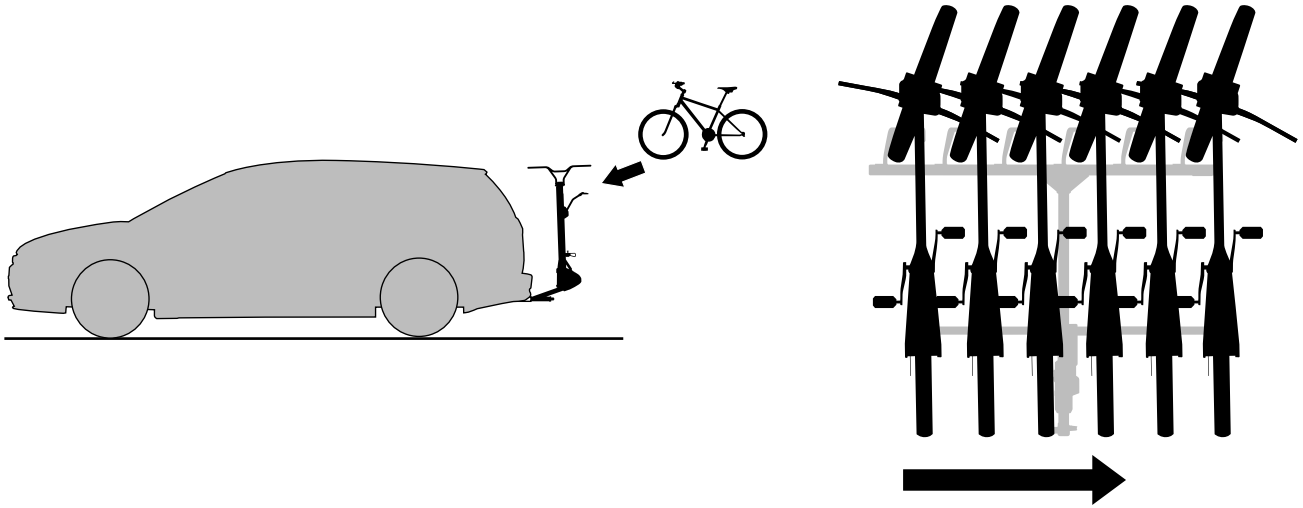

Not ok

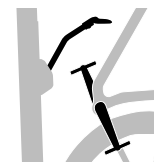

ok

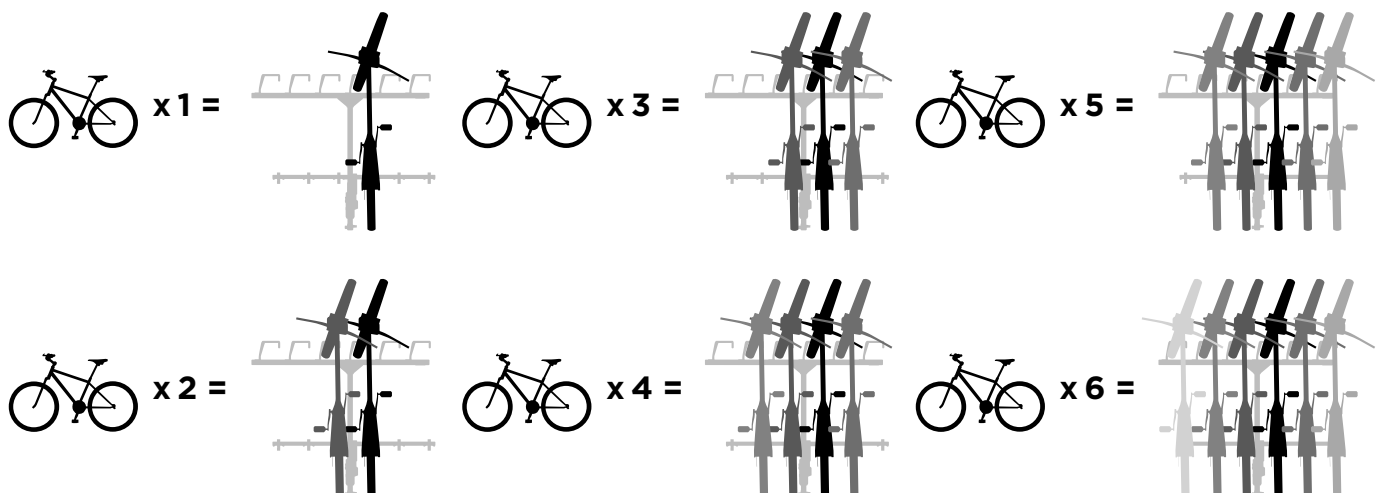
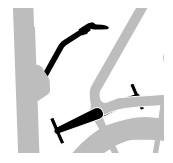

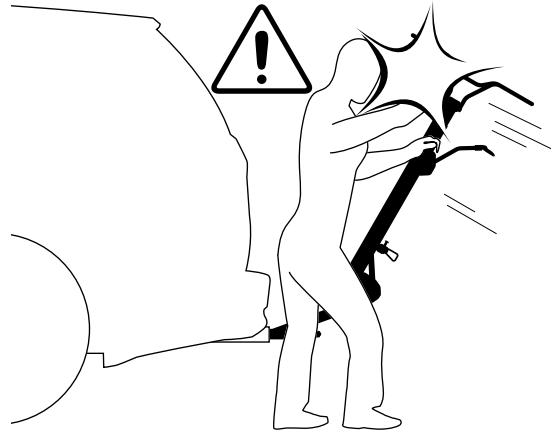
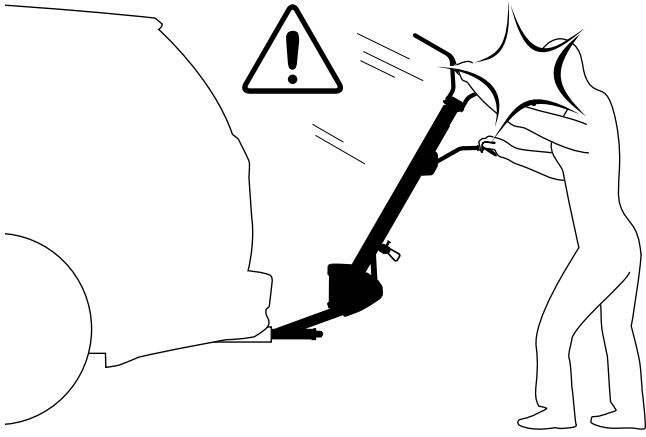

12

A

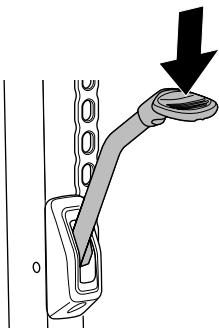

B

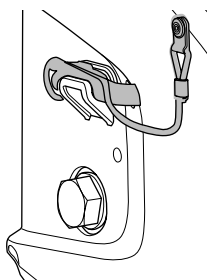
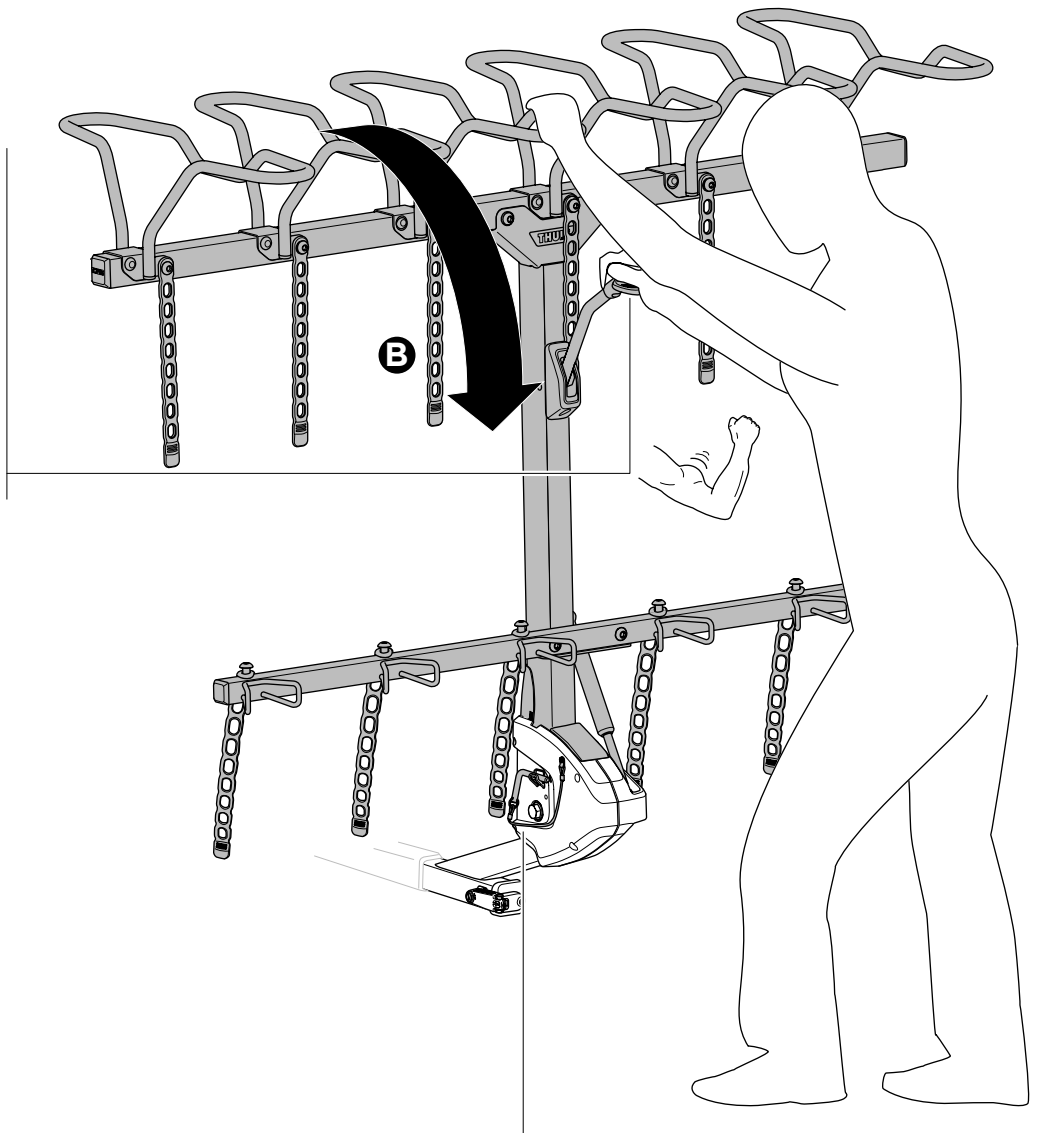

Not ok

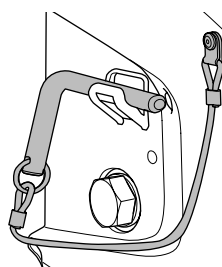

ok



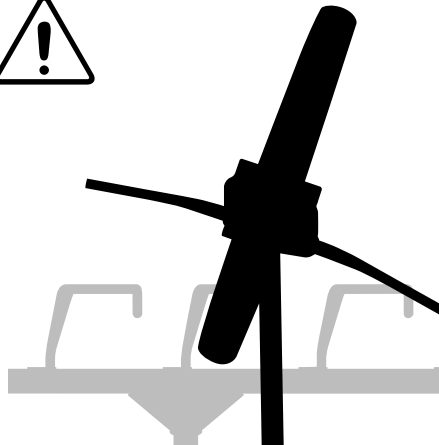
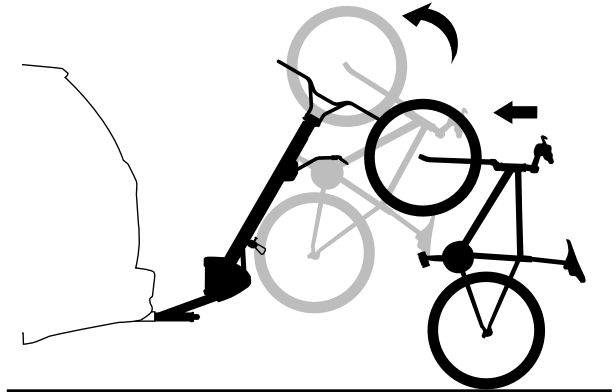
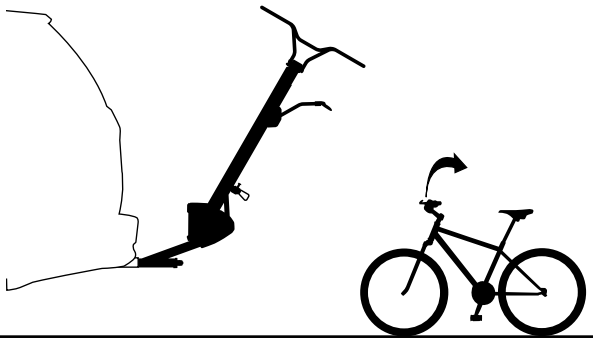
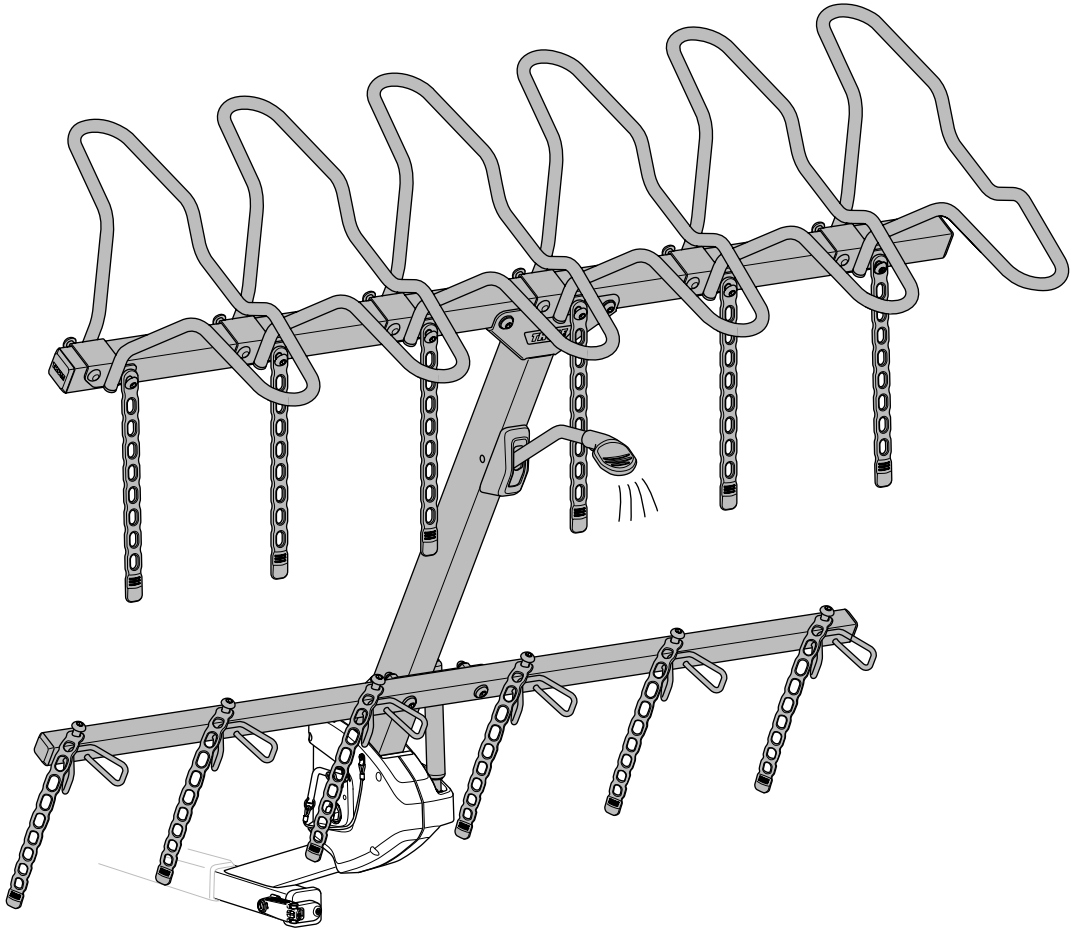

14

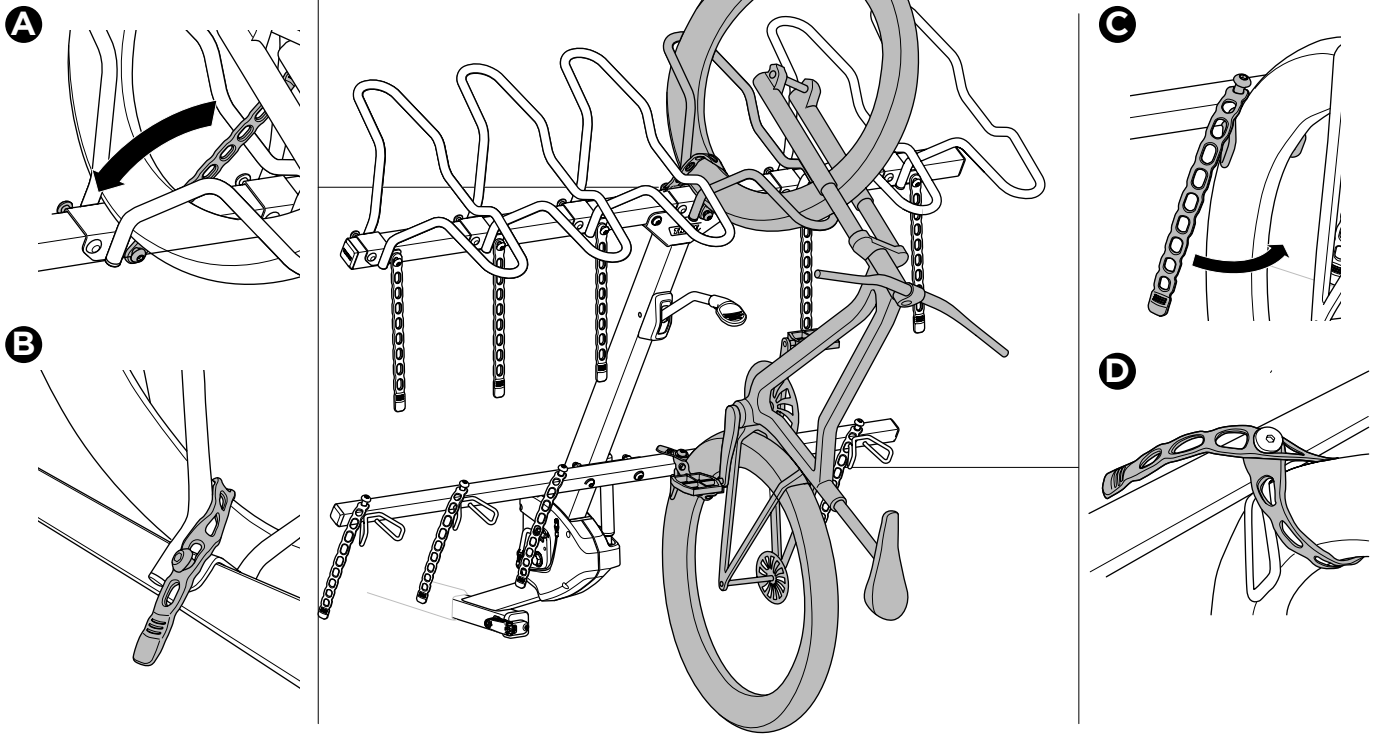

15

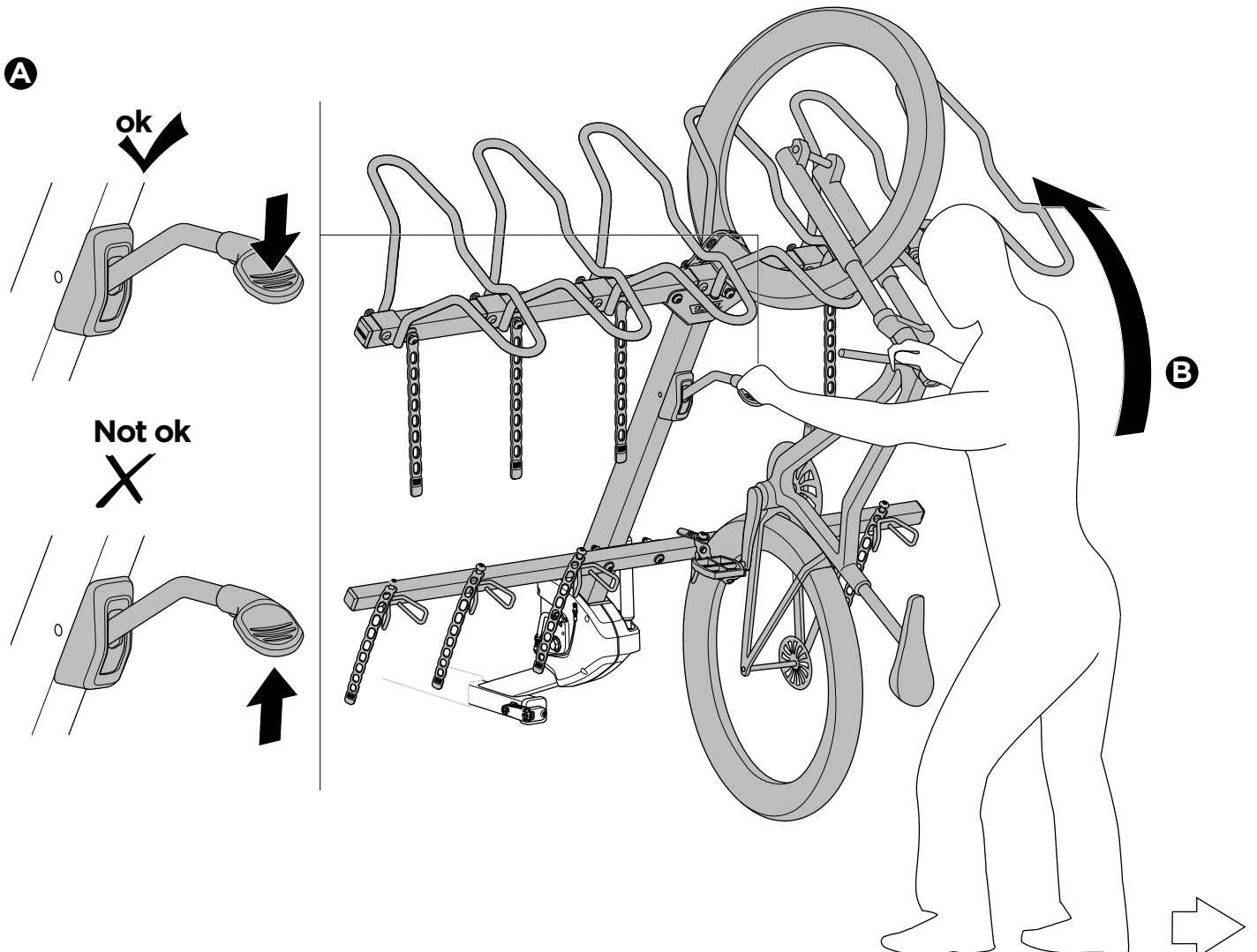

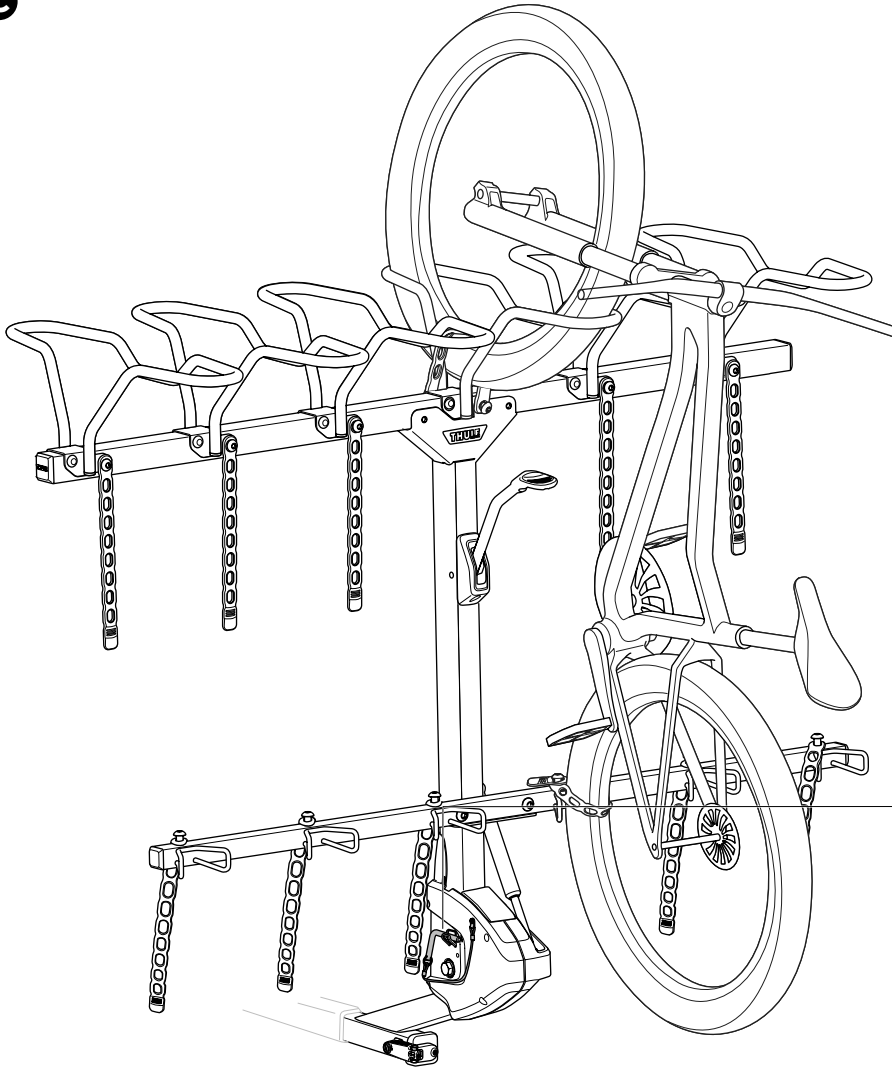
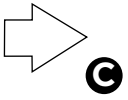

- 1.
- 2.
- 3.

i

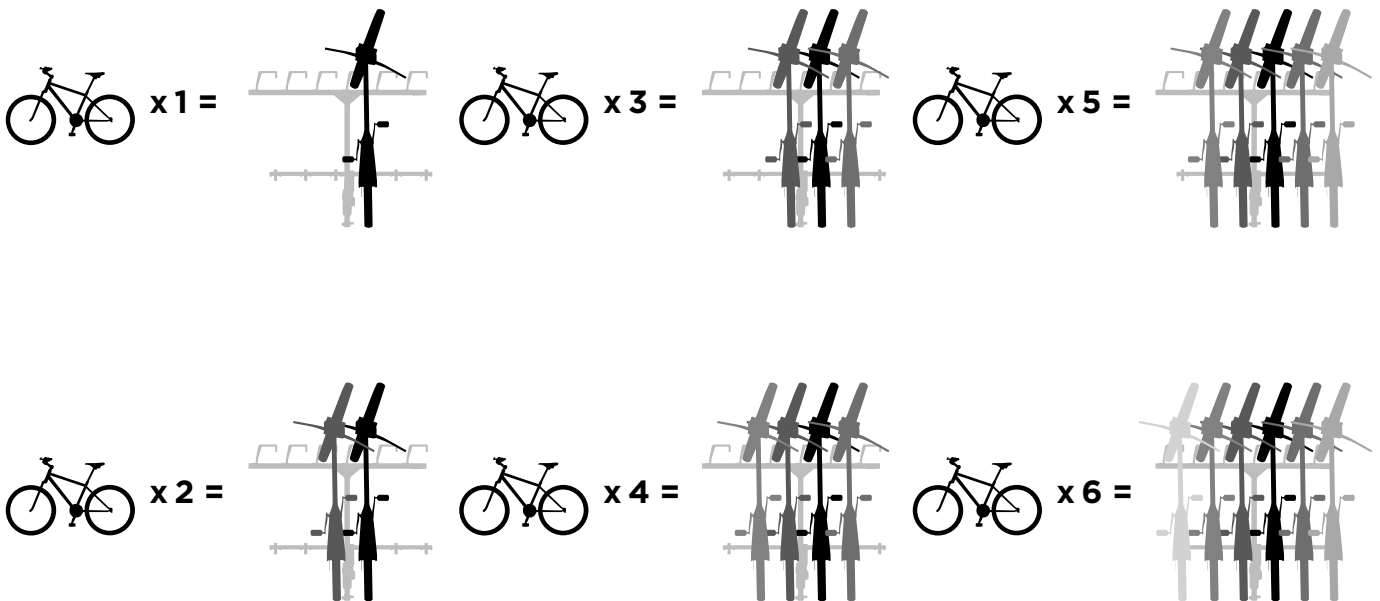

A

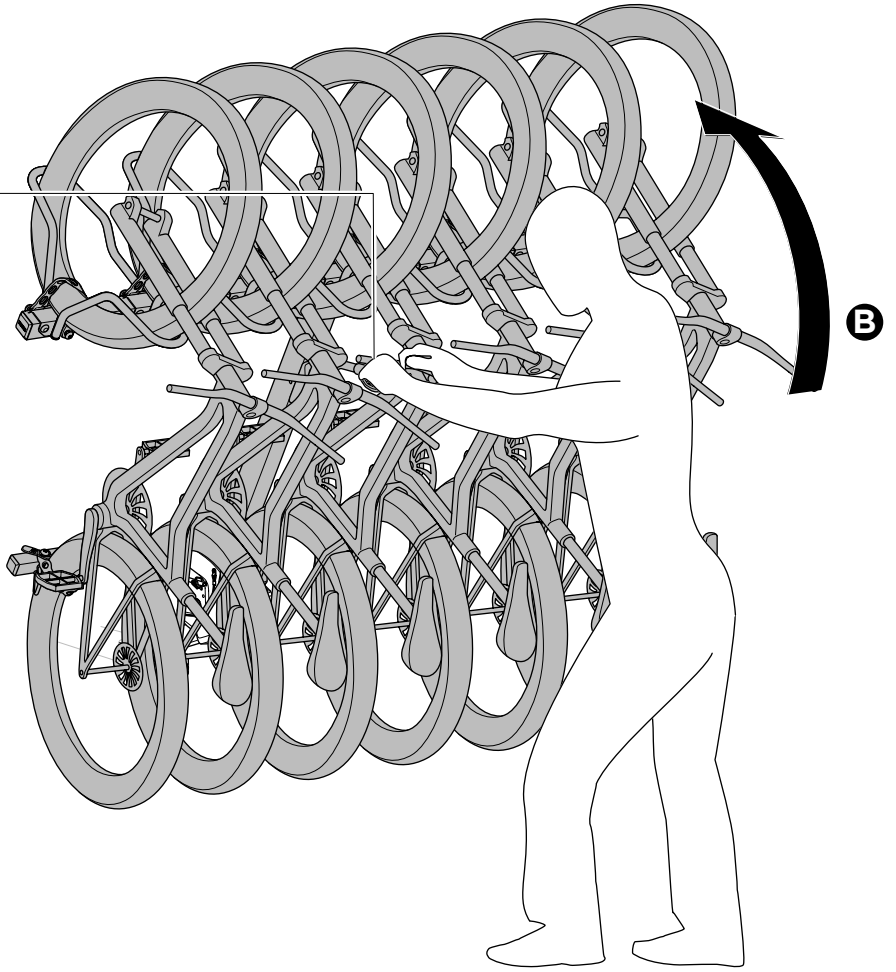
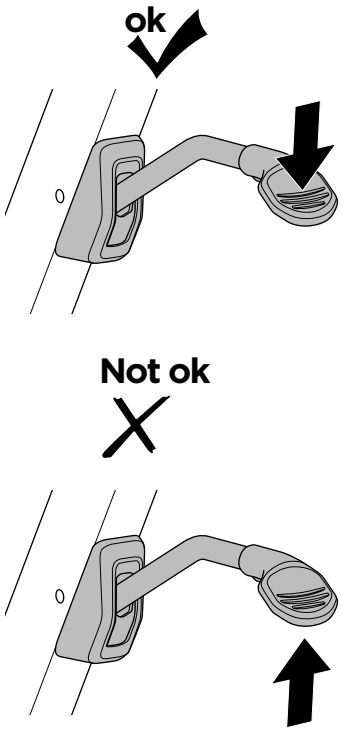

C

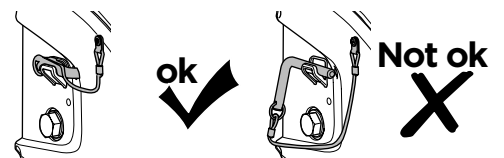
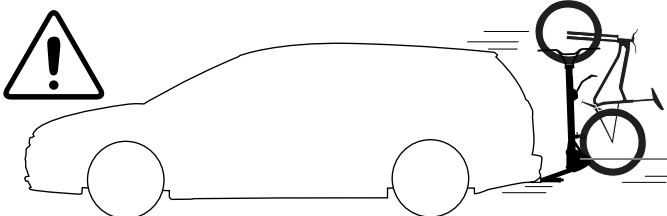
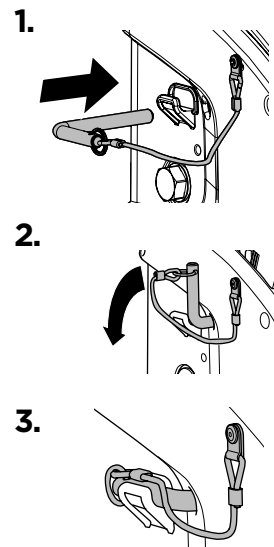
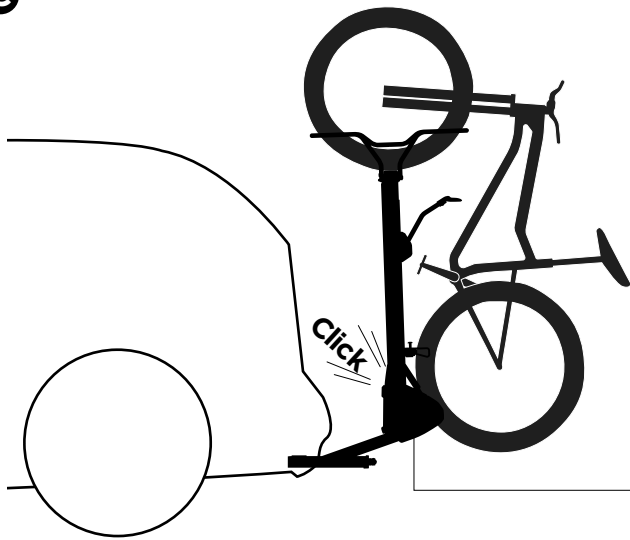

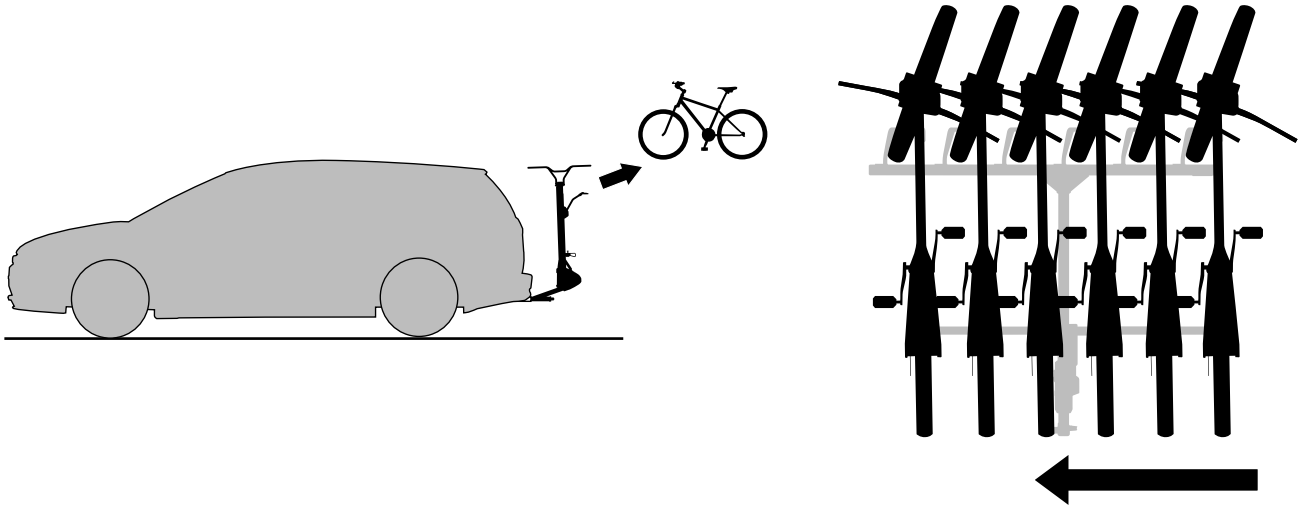

A

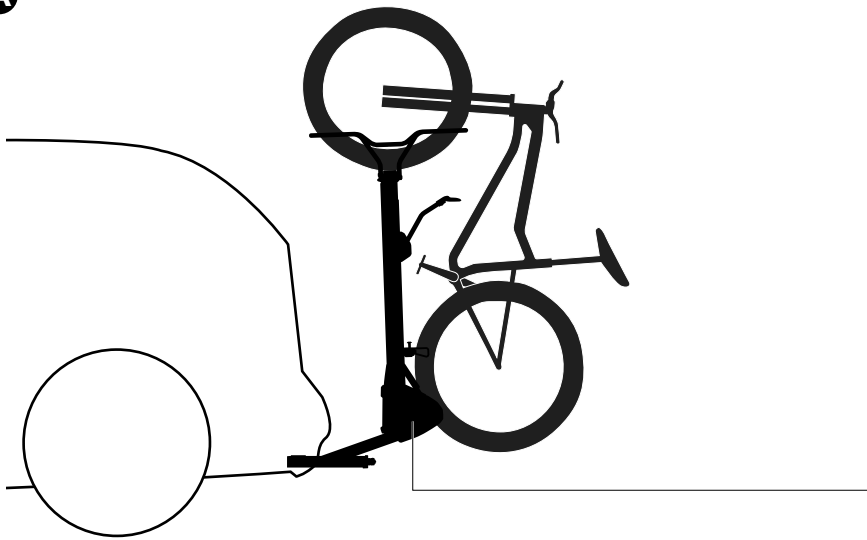

B

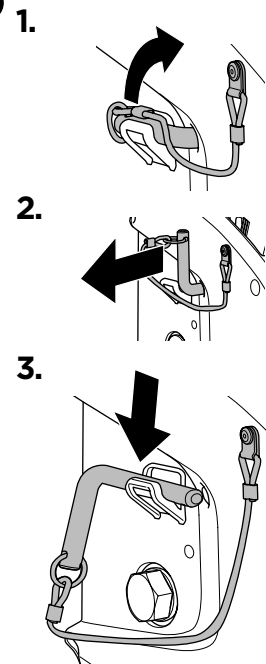

B

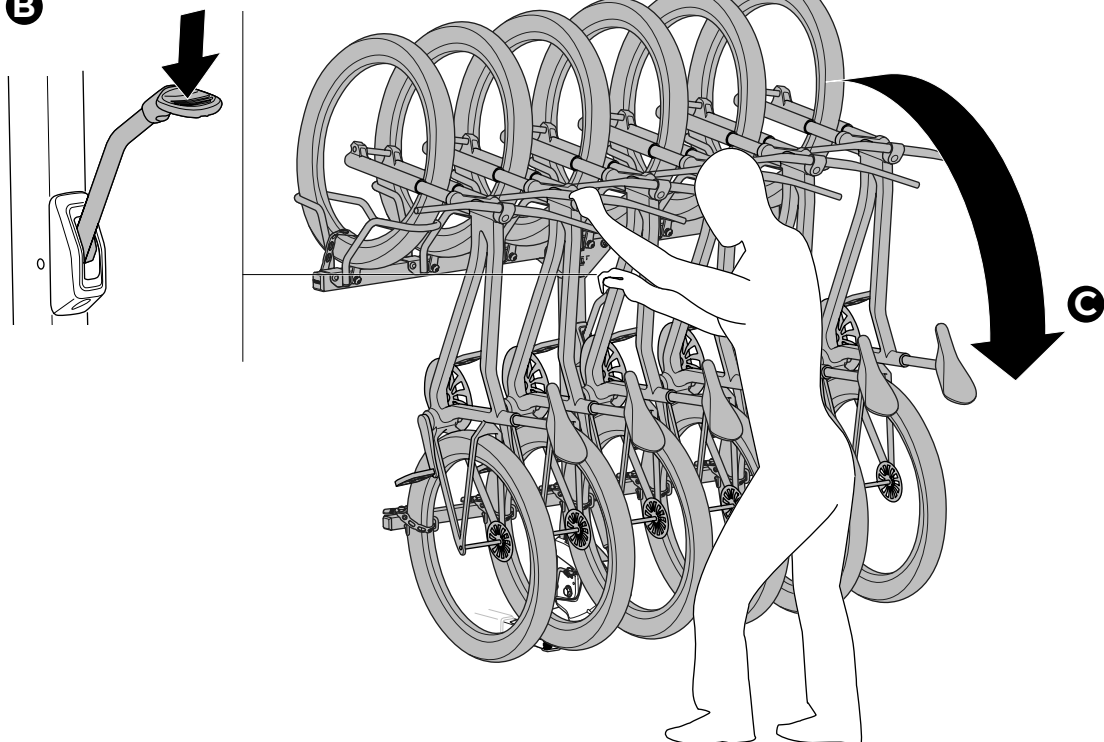

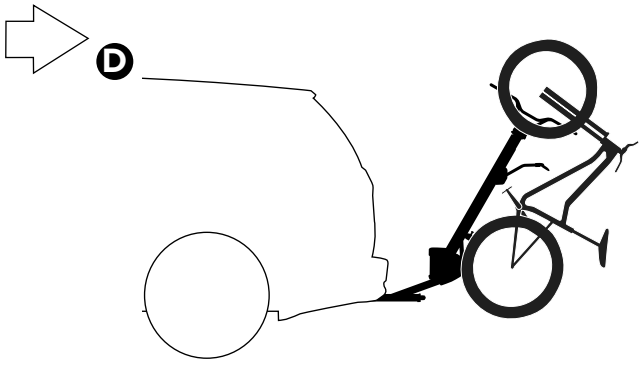

E

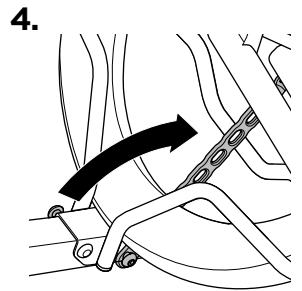
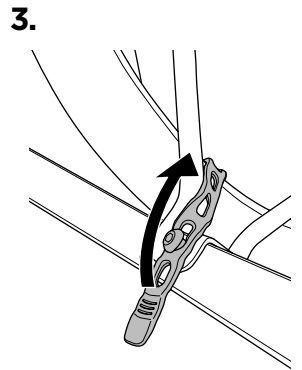
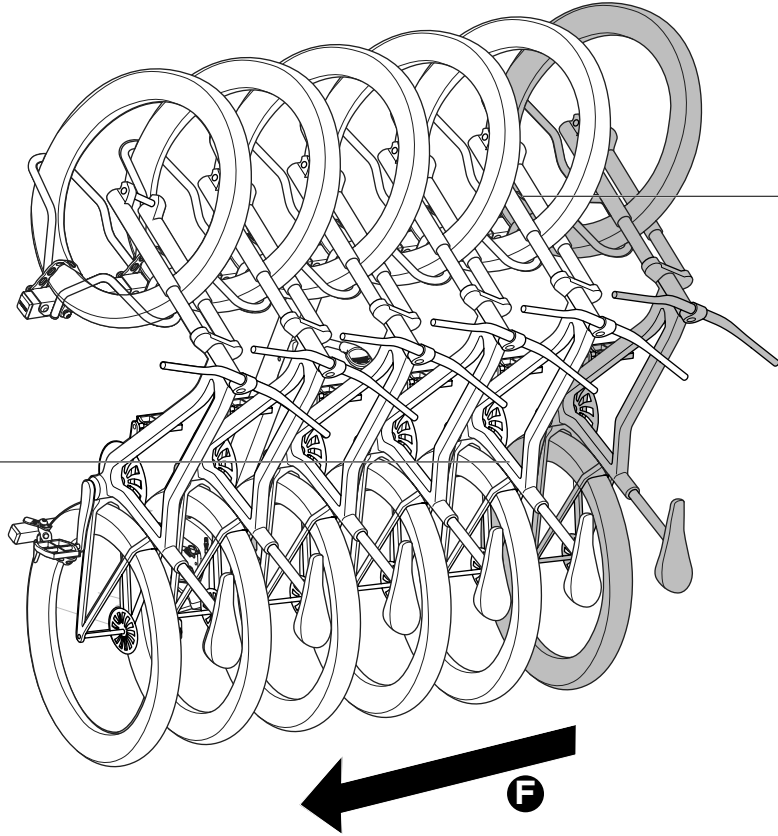
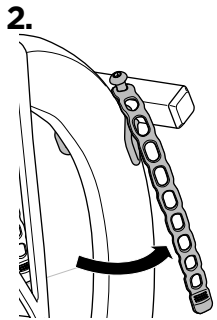
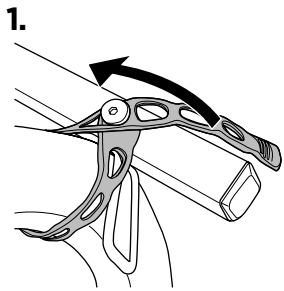

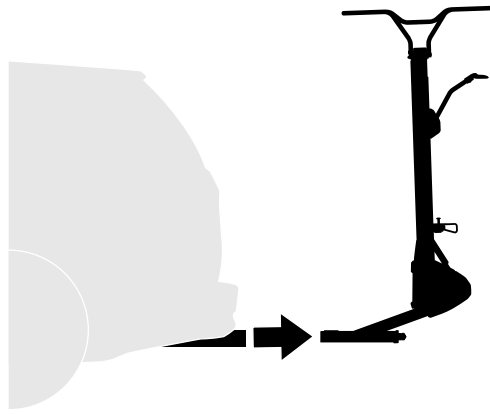

A

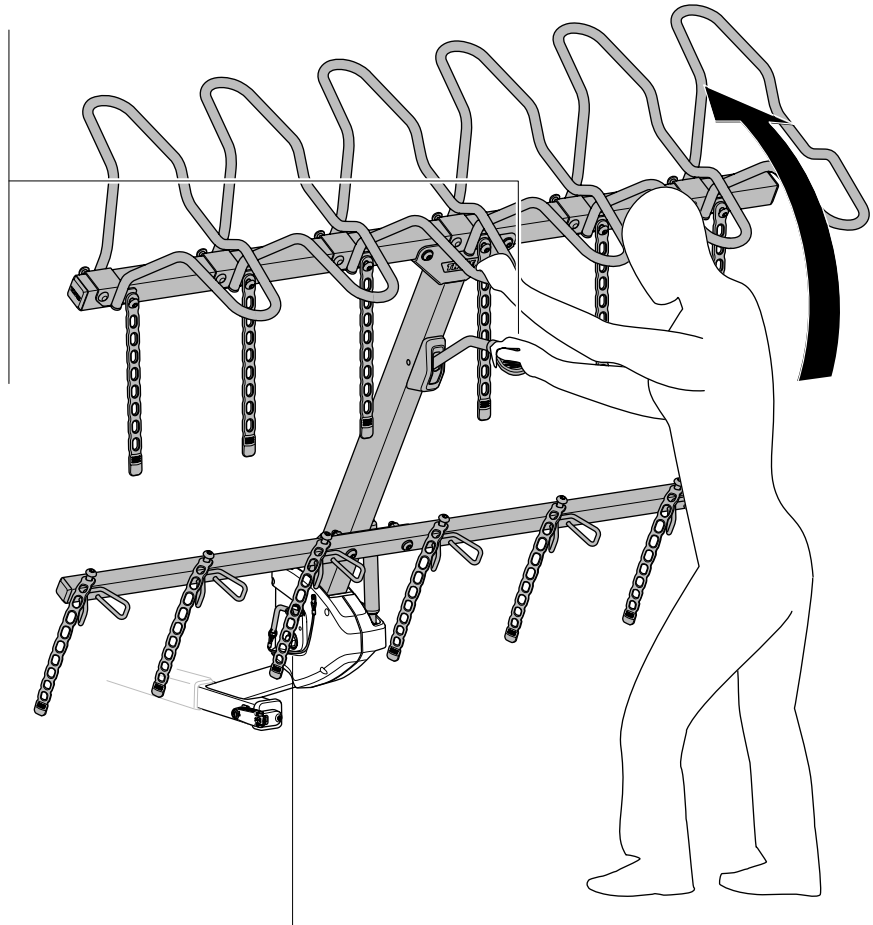
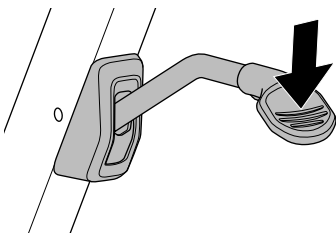

B

C

1.

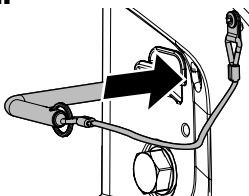

2.

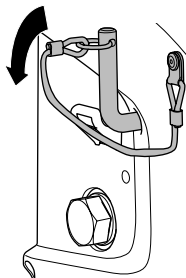

3.

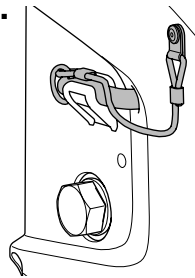

➔ **D**

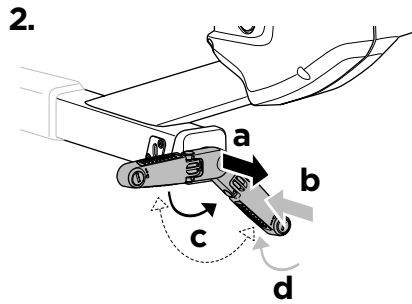
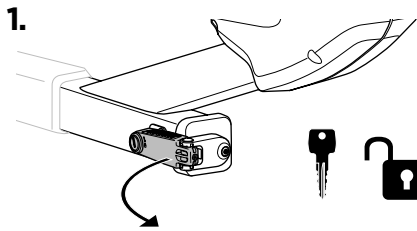
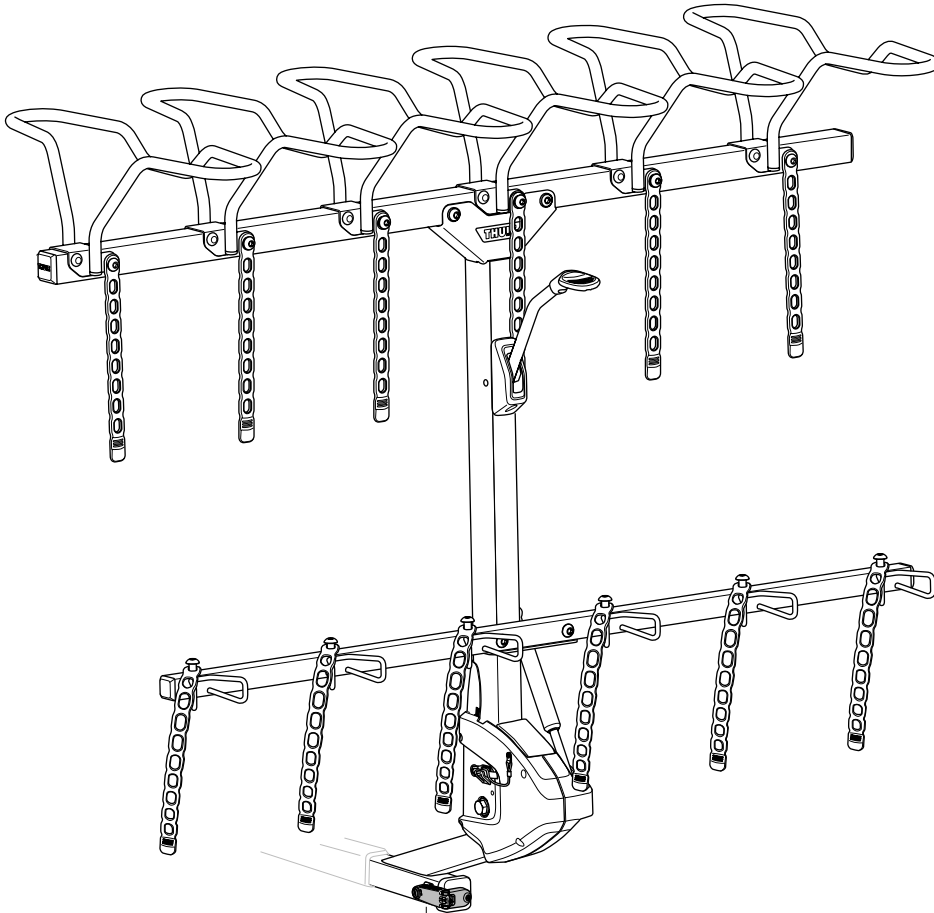

E

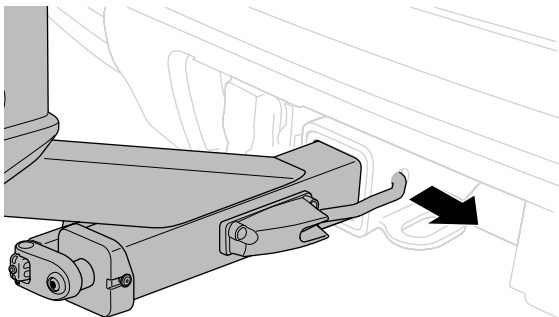

F

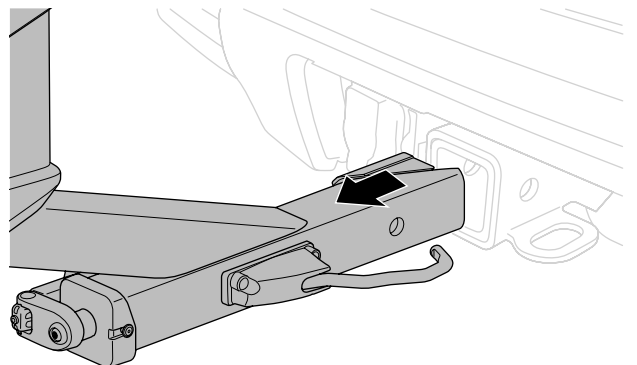

Thule ReVert 20/24" wheel adapter
9020530



Thule ReVert fatbike wheel basket
9020540

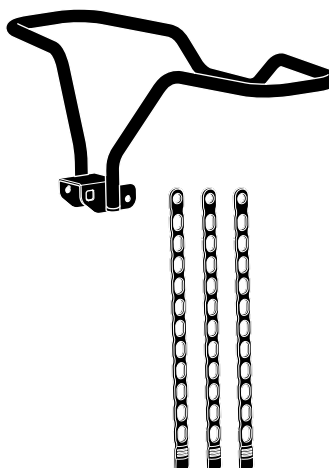

Thule ReVert bike repair holder
9020510



Thule ReVert integrated bike lock
9020520

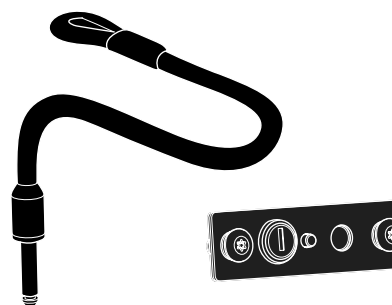

Thule One-Key System

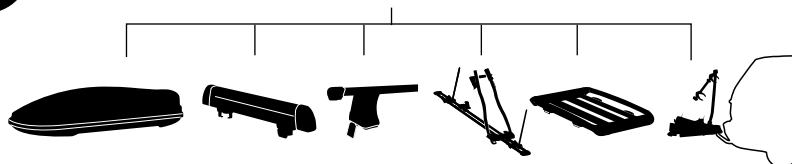

450200  (x2)

450400  (x4)

450600  (x6)

450800  (x8)

Thule Inc. 42 Silvermine Road, Seymour, CT 06483
Thule Canada Inc. 710 Bernard, Granby QC J2J 0H6
North American Consumer Service:
Toll Free 800-238-2388, Fax 450-777-3615
www.thule.com

Register online at:
www.thule.com/register

© Thule Group. All rights reserved.
5564409001 | 2025-06-09 #04

» PART OF THULE GROUP

Technical information

What size is the consumer's hitch?

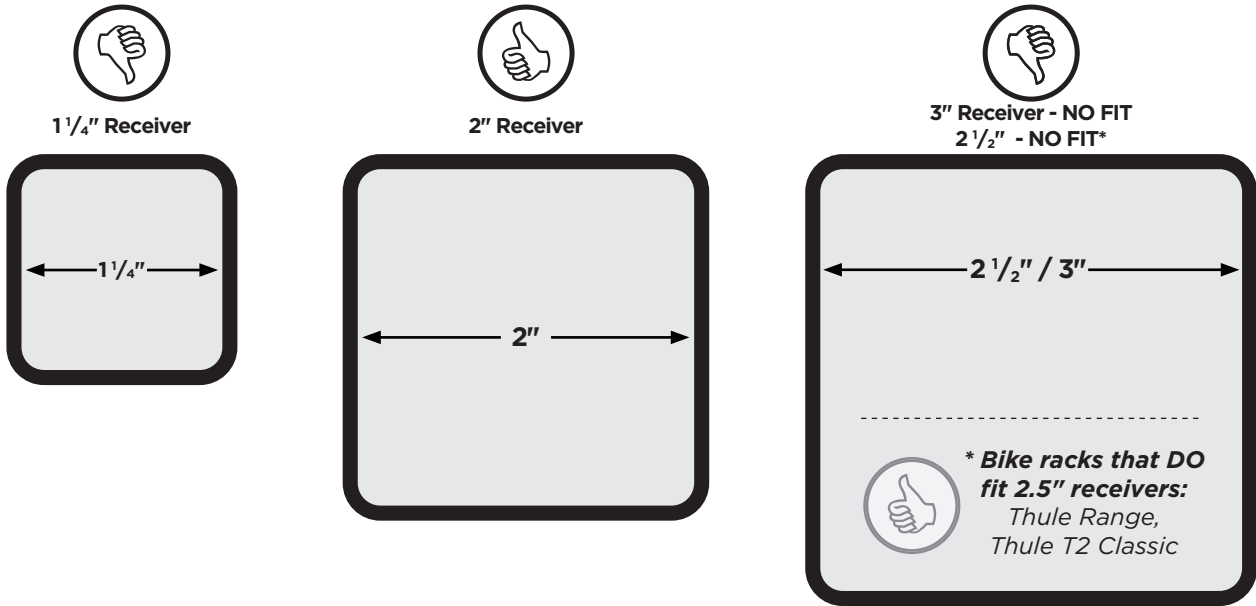

What class is the consumer's hitch?

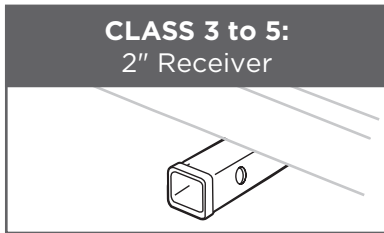

Consumer's hitch pin hole depth?

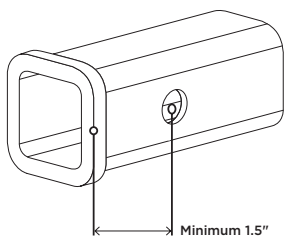

All Thule hitch racks approved for use.

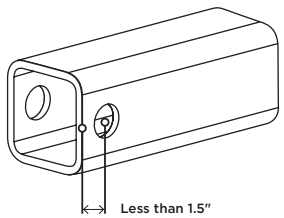

See chart to confirm if Thule hitch rack is approved for use.

PLATFORM	Hitch Rack	Pin Hole Depth Requirement
	Thule ReVert	
	9024500 (4B_2")	1.5"
	9026500 (6B_2")	1.5"

Technical information

Consumer's hitch receiver depth?

To ensure proper fit, it's important to know the depth of your receiver.

Determine this by doing the following:

- With a ruler inserted in the receiver, measure from the center of the hitch mounting hole to the point where you make contact with an obstacle. **This is your receiver depth.**
- If you do not contact a back-stop or your hitch receiver does not have a backstop, another potential point of contact could be an undercarriage-mounted spare tire or the undercarriage itself.
- Using the table in the next page, compare your measurement to see which hitch racks will work with your vehicle.

Your receiver depth must be equal to or greater than the product measurement listed in the table for a proper fit.

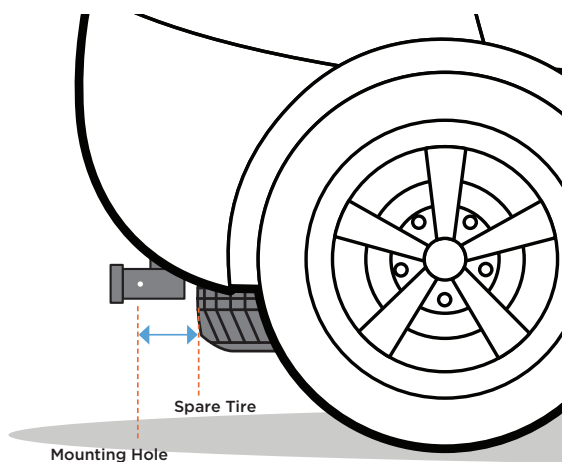
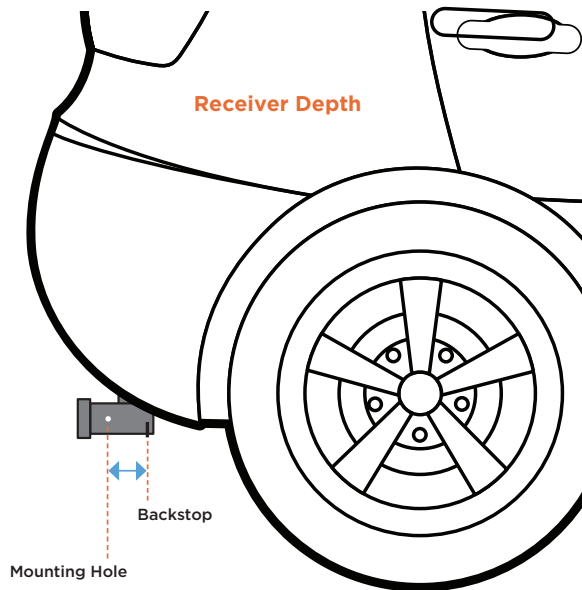

PLATFORM	Hitch Rack	Receiver Depth
	Thule ReVert	
	9024500 (4B_2")	2.55"
	9026500 (6B_2")	2.55"

Technical information

Consumer's hitch bumper clearance?

Make sure your bumper will not interfere with the Thule hitch rack. Measure the distance from the center of the mounting hole on your hitch to the end of your bumper.

This is your bumper clearance.

Your bumper clearance must be equal to or less than the product measurement listed in the table for a proper fit.

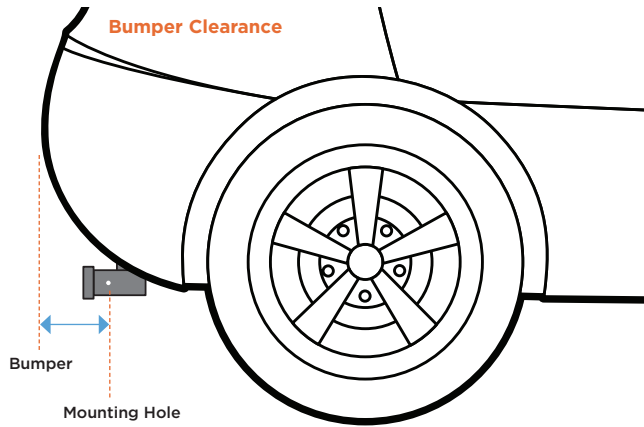

PLATFORM	Hitch Rack	Bumper Clearance
	Thule ReVert	
	9024500 (4B_2")	12.9"
	9026500 (6B_2")	12.9"

Consumer's spare tire clearance?

If you have a spare tire on the back of your vehicle it may interfere with the installation of your Thule hitch rack. Measure the distance from the center of the mounting hole on your hitch receiver to the end of your spare tire.

This is your spare tire clearance.

Your spare tire clearance must be equal to or less than the product measurement listed in the table for a proper fit.

PLATFORM	Hitch Rack	Stowed Spare Tire Clearance	In-use Spare Tire Clearance
	Thule ReVert		
	9024500 (4B_2")	12.9"	-NA-
	9026500 (6B_2")	12.9"	-NA-

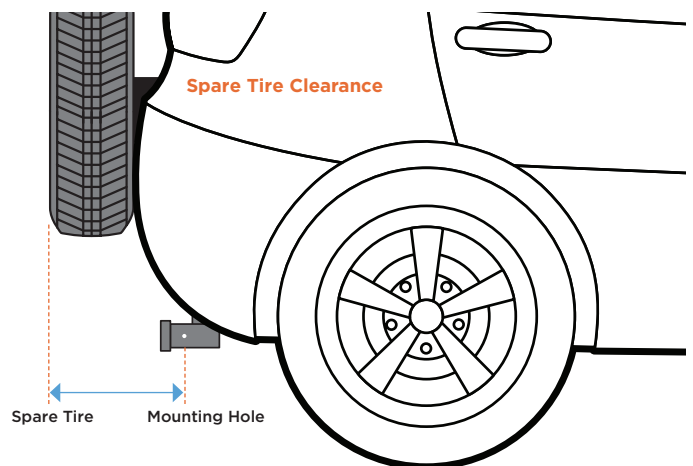

Consumer’s garage clearance?

If you will be parking your vehicle in a garage with the rack mounted, you can use these measurements to help your determine if ther will be any interference issues with fitting your vehicke into your garage space with the rack in the stowed position or deployed position

Garage Clearance

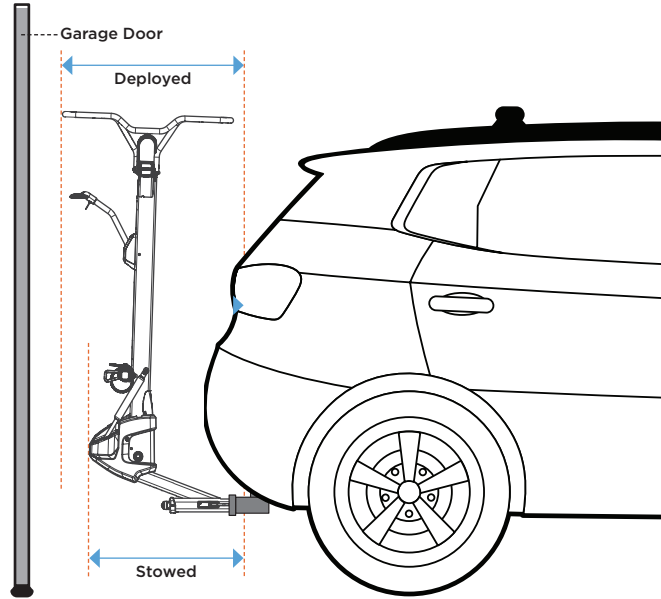

PLATFORM	Hitch Rack	Stowed Clearance	Depolyed Clearance
	Thule ReVert		
	9024500 (4B_2")	27.5"	-NA-
	9026500 (6B_2")	27.5"	-NA-

Hitch dimensions

Through we design our hitch-mounted bike carriers to be as universal as possible, all vehicles are designed differently. These diagrams have been designed to help you better understand the “room” our hitch-mounted bike racks need to function properly.

Tilt hitch racks

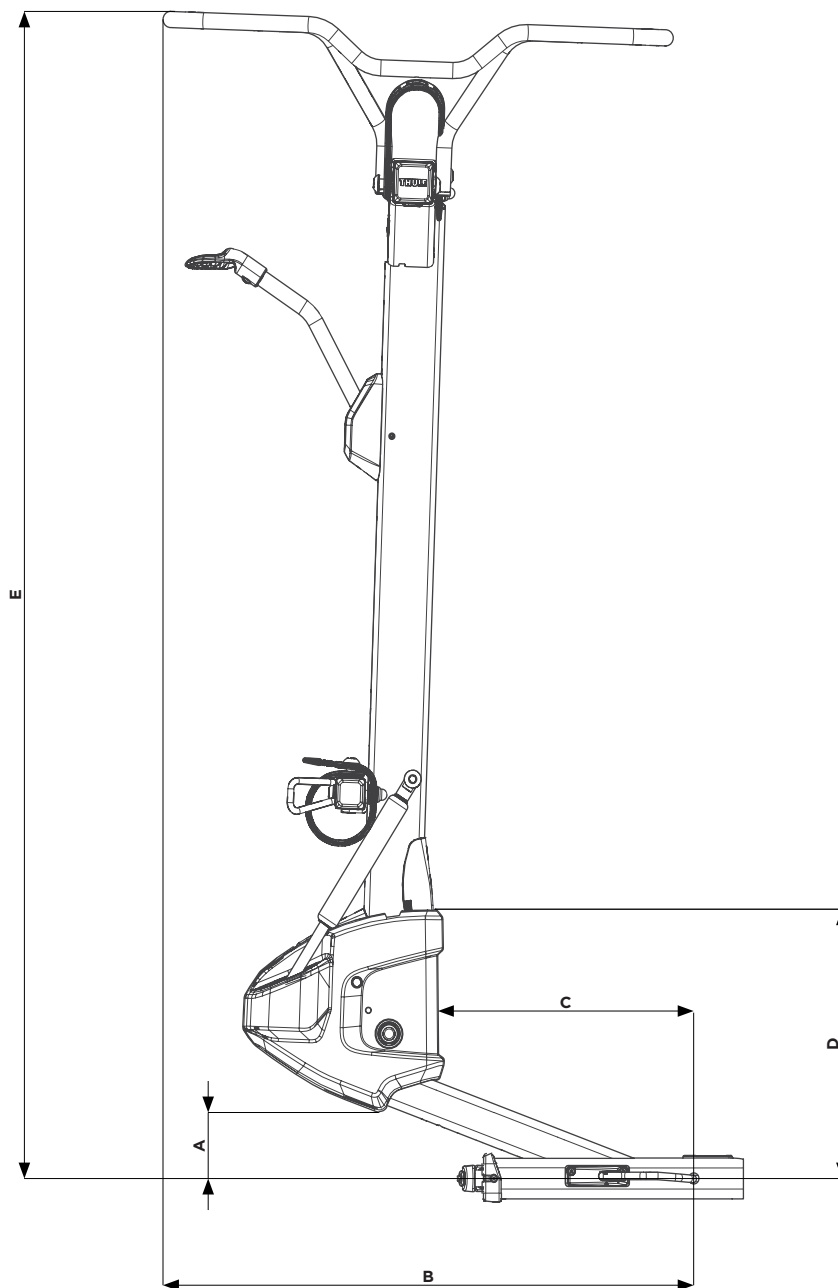

MODEL	A	B	C	D	E
Thule ReVert					
9024500 (4B_2")	3.2"	27.5"	12.9"	13.1"	56.6"
9026500 (6B_2")	3.2"	27.5"	12.9"	13.1"	56.6"