

Severe Heavy Duty U-Joint Service Kit

**TIGER
TOOL**

Have What It Takes

20160

Safety Warning

Read all instructions and safety warnings prior to operation. Failure to do so could result in equipment damage, personal injury or even death.

CAUTION: FAILURE TO CHECK THE SPHERICAL THRUST WASHER AND REPLACE AS NECESSARY MAY RESULT IN UNREPAIRABLE DAMAGE TO YOUR U-JOINT PULLER GLOVE CASTING. PREVENTATIVE MAINTENANCE AS OUTLINED BELOW WILL ENSURE MANY YEARS OF USE FROM YOUR TIGER TOOL PULLER. FAILURE TO PERFORM PREVENTATIVE MAINTENANCE WILL VOID YOUR WARRANTY.

- **Stay Alert!** Watch what you are doing and use common sense when operating this tool.
- Inspect product for damage prior to using; do not use if product is in unsafe condition.
- Do not operate tool while under the influence of drugs, alcohol or medication.
- Always use safety equipment to prevent injuries. Approved face and eye protection must always be worn by the operator, as well as others in the work area.
- Do not overreach. Keep proper footing and balance at all times.
- Dress properly. Do not wear loose clothing or jewelry. Keep your hair, clothing and gloves away from moving parts.
- Keep your work area clean and well lit.

NOTE: HAMMERING THIS TOOL WILL VOID YOUR WARRANTY.



Severe Heavy Duty U-Joint Service Kit

20160

Operating Instructions

Removal

- 1 Remove all retaining rings from bearing cup bores. **(Figure 1)**
- 2 Slip the U-Joint Puller over the yoke ear. **(Figure 2)**
- 3 Turn the forcing screw clockwise with an impact wrench. **(Figure 3)**
- 4 Apply force until the u-joint cross bottoms out on the yoke ear.
- 5 Remove U-Joint Puller from yoke and rotate the driveshaft 180 degrees. **(Figure 4)**

1



2



3



4



Severe Heavy Duty U-Joint Service Kit

20160

Operating Instructions, Cont.

Removal Continued

- 6 Before use, ensure the correct side of SPL 350/RPL35 clamp assembly is facing down. For the SPL 250 LITE, you will need to swap clamp assemblies. **(Figure 5)**

To flip or swap clamp assemblies, you will require internal snap ring pliers and an Allen wrench to remove the two socket head shoulder bolts (items # 7 in the parts breakdown). **(Figure 6)**

- 7 Place the bearing cup extractor over the protruding bearing cup and tighten the $\frac{1}{2}$ " bolt to 35 ft-lbs (Make sure the dowel pins contact a flat surface on the yoke ear). **(Figure 7)**

- 8 Using an impact wrench or ratchet, turn the forcing screw clockwise until the bearing cup is fully extracted. **(Figure 8)**

- 9 Repeat steps 2-5 & 7-8 for remaining bearing cups on driveline.

5



6



7



8



Severe Heavy Duty U-Joint Service Kit

20160

Operating Instructions

Installation

- 10 Clean bearing cup bores of all rust and debris.
- 11 Select & install the corresponding anvil for the driveline being serviced:
 - A For the Spicer drivelines, use the "SPL350" or "SPL250 Lite" anvil;
 - B For the Meritor driveline, use the "RPL35" anvil;
- 12 Press the first bearing cup into the yoke by hand (**Figure 9**), then place the tool over top of the yoke/protruding bearing cup. (**Figure 10**)
- 13 Using a wrench or ratchet, turn the forcing screw clockwise until the bearing cup is about half way installed.
 - A Place the u-joint cross into the yoke and press the bearing cup in the rest of the way until the anvil bottoms out on the yoke ear (make sure the u-joint cross stays concentric with the bearing cup).
- 14 Rotate the driveshaft 180 degrees and install the opposing bearing cup into the yoke by hand. (**Figure 9**)
- 15 Place the tool over top of the yoke/protruding bearing cup (**Figure 10**). Using a wrench or ratchet, turn the forcing screw clockwise until the anvil bottoms out on the yoke ear (**Figure 11**). (make sure the u-joint cross stays concentric to the bearing cup the entire time and rotates freely).
- 16 Remove the installation tool and install new retaining clips. (**Figure 12**).

9



10



11



12



Severe Heavy Duty U-Joint Puller

10106



Have What It Takes

Parts Breakdown

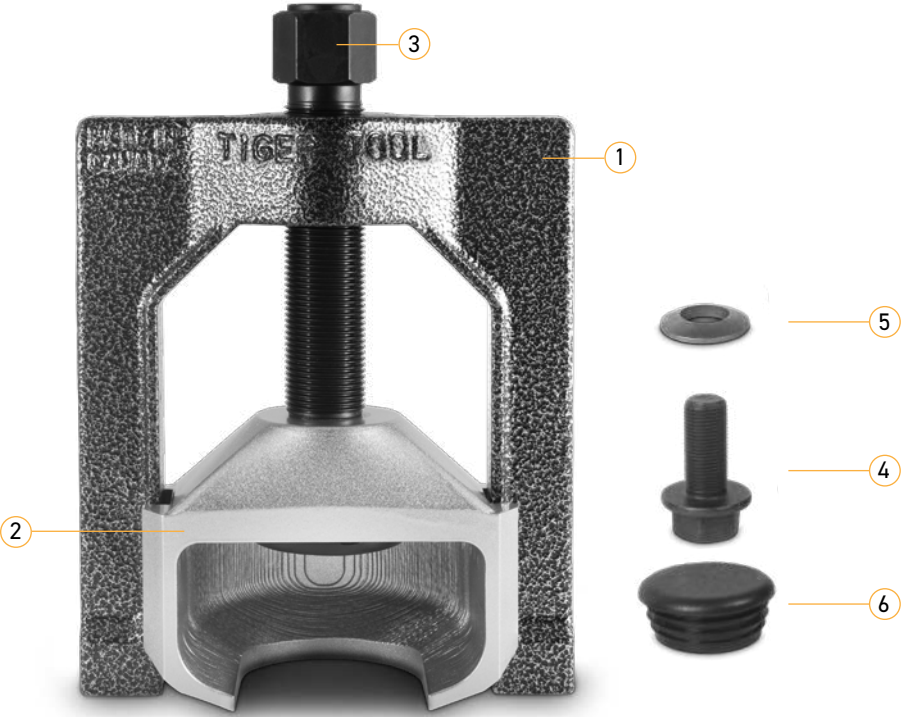

Item No.	Part Number	Description	Qty.
1	10106-1	Fork	1
2	10106-2	Glove	1
3	10102-3	Forcing Screw	1
4	10102-4	Retaining Bolt	1
5	10102-5	Washer	1
6	10102-6	Dome Plug	1

Severe Heavy Duty Bearing Cup Extractor

10107

**TIGER
TOOL**

Have What It Takes

Parts Breakdown

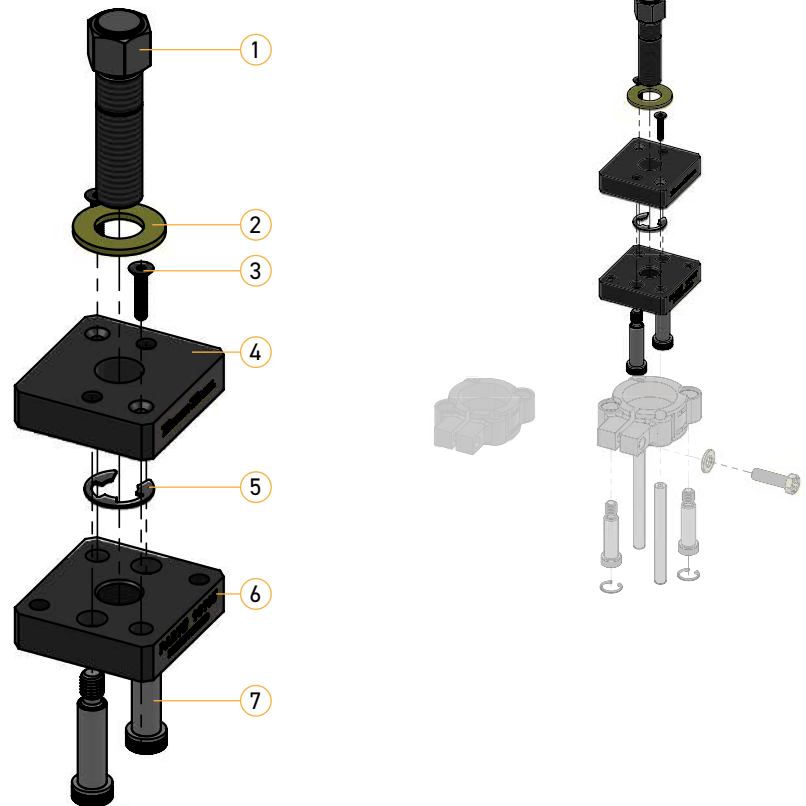

Item No.	Part Number	Description	Qty.
1	10107-7	Forcing Screw	1
2	15001-42	Washer	1
3	10107-13	Hex Drive Flat Head	2
4	10107-3	Top Plate	1
5	10107-8	E Clip	1
6	10107-2	Mid Plate	1
7	10107-11	Socket Shoulder Bolt	4

Severe Heavy Duty Bearing Cup Extractor

10107



Have What It Takes

Parts Breakdown

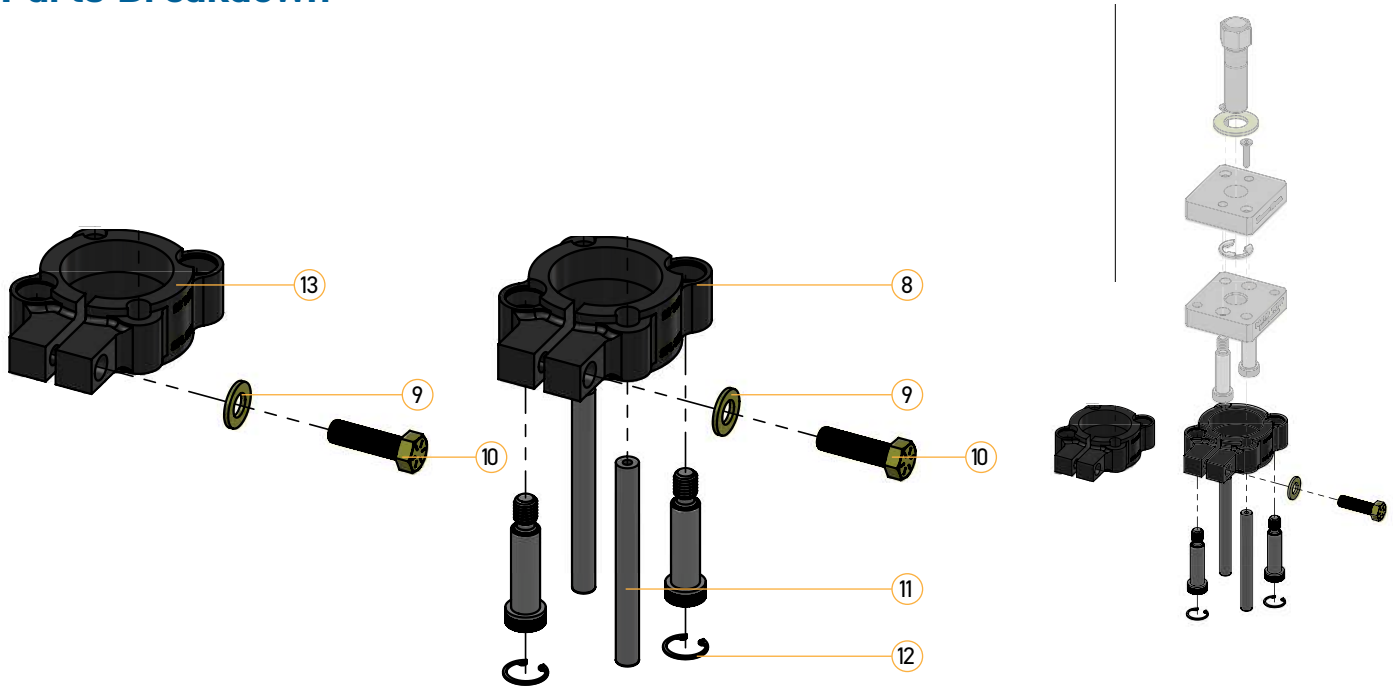

Item No.	Part Number	Description	Qty.
8	10107-1	Clamp Ring	1
9	10407-4	Flat Washer USS	2
10	10107-9	Gr8 Hex Cap Screw	2
11	10107-6	Alloy Pull Dowel Pin	2
12	10107-12	Internal Retaining Ring	2
13	10107-16	SPL 250 Lite Clamp	1

Severe Heavy Duty Bearing Cup Installer

10218

**TIGER
TOOL**

Have What It Takes

Parts Breakdown

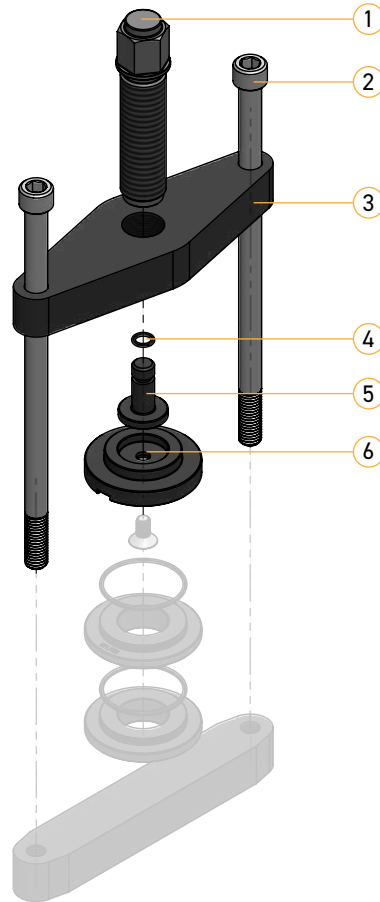

Item No.	Part Number	Description	Qty.
1	90150-13	Forcing Screw - Short	1
2	10218-14	SHCS	2
3	10218-1	Installer Top Plate	1
4	90150-14	O-Ring	1
5	10218-3	Installer Anvil	1
6	10218-13	Adapter	1

Severe Heavy Duty Bearing Cup Installer

10218

**TIGER
TOOL**

Have What It Takes

Parts Breakdown

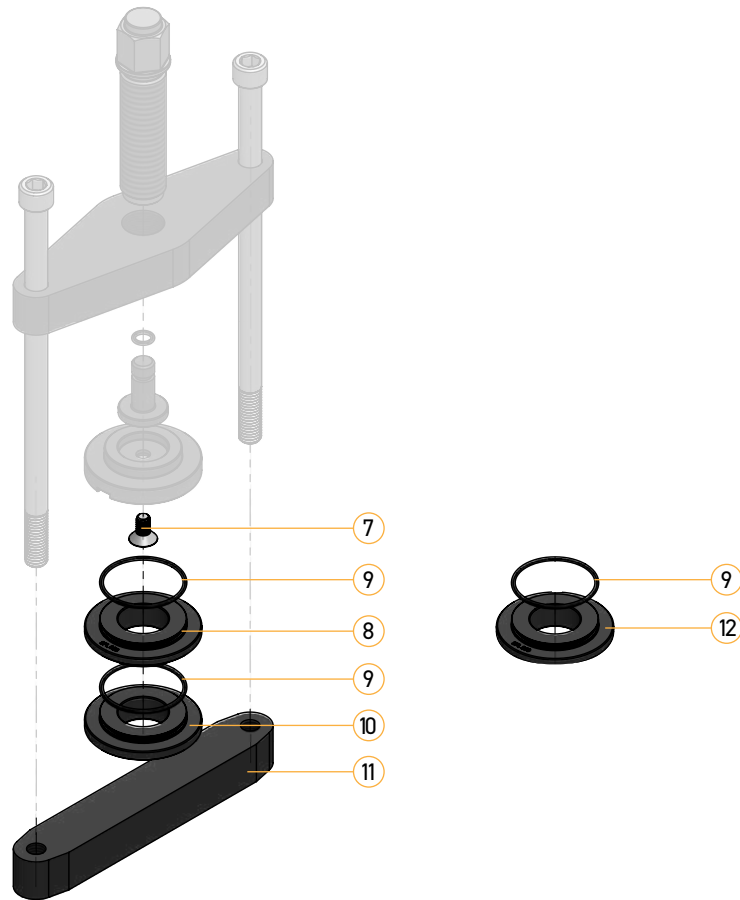

Item No.	Part Number	Description	Qty.
7	10100-5	FHMS	1
8	10218-4	Anvil End Plate - SPL 350	1
9	10218-12	O-Ring	3
10	10218-5	Anvil End Plate - RPL 35	1
11	10218-2	Installer Bottom Plate	1
12	10218-15	Anvil End Plate - SPL Lite	1

When it comes to quality suspension and steering service tools, Tiger Tool is the brand you can depend on.