

FF700

FORD

Front suspension package

INSTALLATION INSTRUCTIONS

- a) Raise vehicle allowing the axle to hang freely.
- b) Remove existing bump stop assembly.
- c) Assemble Aeon rubber spring and bracket as shown in the adjacent diagram.
- d) Mount Timbren assembly using existing holes & Timbren supplied fasteners.
- e) Lower vehicle.

Do not exceed vehicle manufacturer's recommended axle weight rating. Check for AEON[®] interference with vehicle components - Under load AEON[®] will "expand" in diameter.

Ref. = Reference
Part = Part #.
Qty. = Quantity

Ref	Part	Qty
1	F31003-150	2
2	F40031-020	2
3	K10154-003	2
4	A00540-55Q30	2
5	F11071-150	2

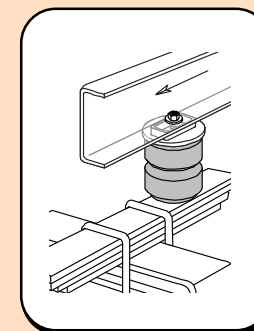
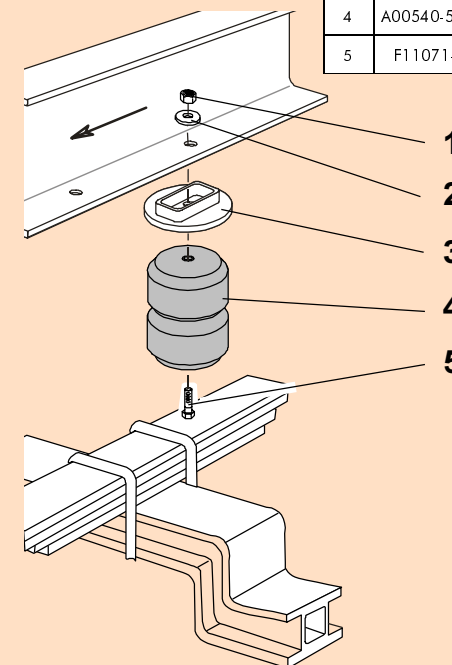

FF700



FF700

PART NUMBER	DESCRIPTION	QTY	LOCATION
F31003-150	NYLOCK LOCKNUT 3/8 UNF GR 5 Z	2	G1C
F40031-020	WASHER FLAT USS 3/8 x 1 GR 2 Z	2	G1C
F11071-150	HCS 3/8 x 3-1/2 UNF GR 5 Z	2	G2C
A00540-55Q30	Hollow Rubber Spring	2	C9A
K10154-003	FF700 / GMRC30 WELDMENT PTD.	2	D15D
B90200-CF	SMALL FRONT BOX - 9.5 x 7 x 5.5	1	A--E
B10000	8" x 12" BUBBLE FOR KITS	1	
B00029-010	BARCODE LABEL FOR KIT	1	

Clearance Instructions:

Rear SES Kits for Pick-Ups and Vans should have a 1/2" to 1-1/2" gap between the rubber spring and contact point when empty.

A partial load, or vehicle accessories will reduce or eliminate the gap.

Front SES kits are usually in full contact.

Medium and Heavy-Duty Trucks, Trailers and Motorhomes will be in constant contact, and have no gap.