

FFCOL

FREIGHTLINER

Front suspension package

INSTALLATION INSTRUCTIONS

- a) Raise vehicle allowing the axle to hang freely.
- b) Disconnect upper shock bracket from frame & retain hardware.
- c) Assemble Aeon rubber spring and bracket as shown in the adjacent diagram.
- d) Mount Timbren spring assembly between shock mount bracket and chassis frame.
- e) Tighten using OEM fasteners - torque to OEM specifications.
- f) Lower vehicle.

NOTES:

Use rubber washer #2 and bolt #5 to achieve desired ride height.
When removing OEM fasteners, use penetrating fluid.

Do not exceed vehicle manufacturer's recommended axle weight rating. Check for AEON® interference with vehicle components - Under load AEON® will "expand" in diameter.

Ref. = Reference
Part = Part #.
Qty. = Quantity

Ref	Part	Qty
1	K10467-005	1L-1R
2	A25723-90AH00	2
3	A00540-65Q30	2
4	F11538-350	2
5	F11542-750	2

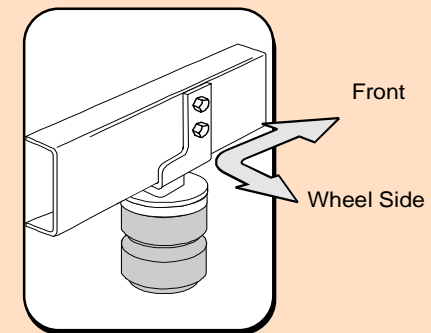
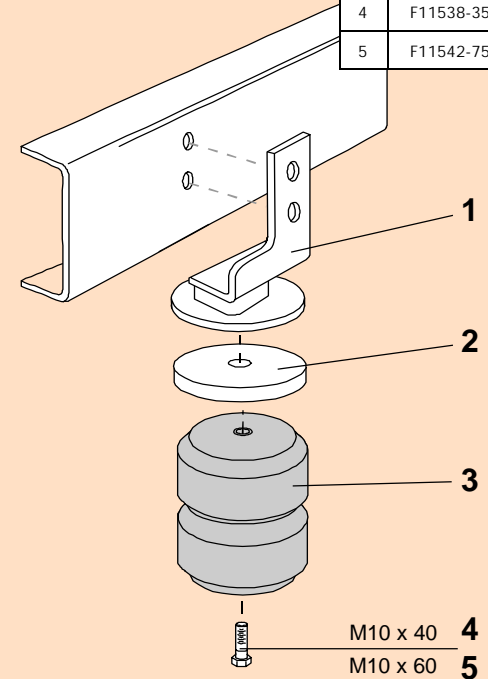

FFCOL

PART NUMBER	DESCRIPTION	QTY	LOCATION
F11538-350	HCS M10 x 40 x 1.5 Gr 8.8 Z	2	I1C
F11542-750	HCS M10 x 60 x 1.5 F/T Gr 8.8 Z	2	I2D
A00540-65Q30	Hollow Rubber Spring	2	C8B
A25723-90AH00	RUBBER SPACER 4"od x 1" thk w/ AH Bushing	2	
K10467LH-005	FFCOL WELDMENT LH PAINTED	1	D16E
K10467RH-005	FFCOL WELDMENT RH PAINTED	1	D16E
B90201-CF	LARGE FRONT BOX - 10.5 x 8.5 x 6	1	A--D
B10000	8" x 12" BUBBLE FOR KITS	1	
B00029-010	BARCODE LABEL FOR KIT	1	

ASSEMBLY NOTES:

APPLY 'LEFT' LABEL TO L/H BRACKET.

Clearance Instructions:

Rear SES Kits for Pick-Ups and Vans should have a 1/2" to 1-1/2" gap between the rubber spring and contact point when empty.

A partial load, or vehicle accessories will reduce or eliminate the gap.

Front SES kits are usually in full contact.

Medium and Heavy-Duty Trucks, Trailers and Motorhomes will be in constant contact, and have no gap.