

FFFL112

FREIGHTLINER

INSTALLATION INSTRUCTIONS

- Raise vehicle allowing the axle to hang freely.
- Remove top shock mounting bolts.
- Assemble Aeon rubber spring and bracket as shown in the adjacent diagram.
- Mount Timbren spring assembly between shock mount bracket and chassis frame.
- Tighten using Timbren fasteners provided & torque to OEM specifications.
- Lower vehicle.

Do not exceed vehicle manufacturer's recommended axle weight rating. Check for AEON® interference with vehicle components - Under load AEON® will "expand" in diameter.

Ref. = Reference
Part = Part #.
Qty. = Quantity

Ref	Part	Qty
1	F31007-150	4
2	F40071-020	4
3	F11146-150	4
4	K10276-003	1L-1R
5	A00540-65E60	2
6	F11104-150	2

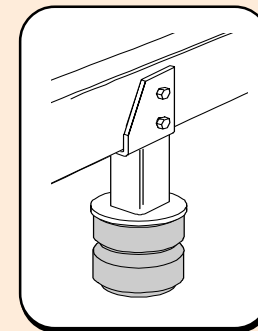
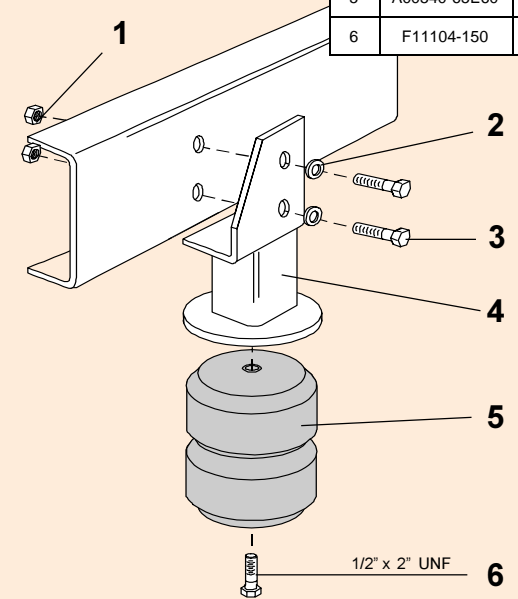

FFFL112

PART NUMBER	DESCRIPTION	QTY	LOCATION
F31007-150	NYLOCK LOCKNUT 5/8 UNF GR 5 Z	4	H2E
F40071-020	WASHER FLAT USS 5/8 x 1-3/4 GR 2 Z	4	H2E
F11146-150	HCS 5/8 x 2-1/2 UNF GR 5 Z	4	H2E
F11104-150	HCS 1/2 x 2 UNF GR 5 Z	2	G1D
A00540-65E60	Hollow Rubber Spring	2	C8B
K10276LH-003	FFFL112 WELDMENT LH PAINTED	1	E3B
K10276RH-003	FFFL112 WELDMENT RH PAINTED	1	E3B
B90224	12 x 11 x 8-1/2" DW Carton	1	A1A
B10100	NEWSPRINT 18" ROLL	1	
B00029-010	BARCODE LABEL FOR KIT	1	

ASSEMBLY NOTES:

APPLY 'LEFT' LABEL TO L/H BRACKET.

Clearance Instructions:

Rear SES Kits for Pick-Ups and Vans should have a 1/2" to 1-1/2" gap between the rubber spring and contact point when empty.

A partial load, or vehicle accessories will reduce or eliminate the gap.

Front SES kits are usually in full contact.

Medium and Heavy-Duty Trucks, Trailers and Motorhomes will be in constant contact, and have no gap.