

# FFFL80

## FREIGHTNINER

Front suspension package

### INSTALLATION INSTRUCTIONS

- a) Raise vehicle allowing the axle to hang freely.
- b) Remove top shock mounting bolts.
- c) Assemble Aeon rubber spring and bracket as shown in the adjacent diagram.
- d) Mount Timbren spring assembly between shock mount bracket and chassis frame.
- e) Tighten using Timbren fasteners provided - torque to OEM specifications.
- f) Lower vehicle.

Ref. = Reference  
Part = Part #.  
Qty. = Quantity

Ref	Part	Qty
1	F31005-150	2
2	F40053-020	2
3	F31007-150	2
4	F40071-020	2
5	K10163-003	1L-1R
6	F11142-150	2
7	F11102-150	2
8	A00540-65E60	2
9	F11103-150	2

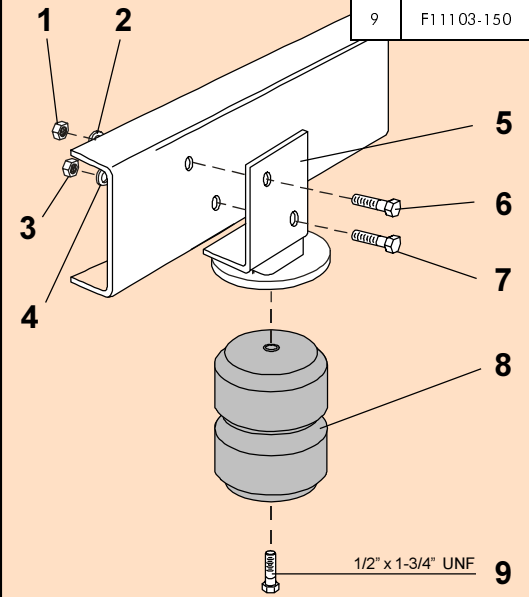

*Do not exceed vehicle manufacturer's recommended axle weight rating. Check for AEON® interference with vehicle components - Under load AEON® will "expand" in diameter.*

## FFFL80

PART NUMBER	DESCRIPTION	QTY	LOCATION
F31007-150	NYLOCK LOCKNUT 5/8 UNF GR 5 Z	2	H2E
F40071-020	WASHER FLAT USS 5/8 x 1-3/4 GR 2 Z	2	H2E
F11142-150	HCS 5/8 x 1-1/2 UNF GR 5 Z	2	H2E
F31005-150	NYLOCK LOCKNUT 1/2 UNF GR 5 Z	2	G1D
F40053-020	WASHER FLAT 1/2 x 1-1/2 GR 2 Z	2	G4A
F11102-150	HCS 1/2 x 1-1/2 UNF GR 5 Z	2	G1D
F11103-150	HCS 1/2 x 1-3/4 UNF GR 5 Z	2	G1D

A00540-65E60	Hollow Rubber Spring	2	C8B
--------------	----------------------	---	-----

K10163LH-003	FFFL80 WELD'T (PAINTED)	2	D8E
K10163RH-003	FFFL80 WELD'T (PAINTED)	2	D8E

B90223	10-3/4 x 9-1/2 x 7 DW Carton	1	A1A
B10100	NEWSPRINT 18" ROLL	1	
B00029-010	BARCODE LABEL FOR KIT	1	

### ASSEMBLY NOTES:

APPLY 'LEFT' LABEL TO L/H BRACKET.

### Clearance Instructions:

Rear SES Kits for Pick-Ups and Vans should have a 1/2" to 1-1/2" gap between the rubber spring and contact point when empty.

A partial load, or vehicle accessories will reduce or eliminate the gap.

Front SES kits are usually in full contact.

Medium and Heavy-Duty Trucks, Trailers and Motorhomes will be in constant contact, and have no gap.