

# FFFL80A

# FREIGHTLINER

Front suspension package

### INSTALLATION INSTRUCTIONS

- a) Raise vehicle allowing the axle to hang freely.
- b) Remove top shock mounting bolts.
- c) Assemble Aeon rubber spring and bracket as shown in the adjacent diagram.
- d) Mount Timbren spring assembly between shock mount bracket and chassis frame.
- e) Tighten using OEM fasteners - torque to OEM specifications.
- f) Lower vehicle.

*Do not exceed vehicle manufacturer's recommended axle weight rating. Check for AEON<sup>®</sup> interference with vehicle components - Under load AEON<sup>®</sup> will "expand" in diameter.*

**Ref.** = Reference =  
**Part** = Part #.  
**Qty.** = Quantity

Ref	Part	Qty
1	K10325-003	1L-1R
2	A00535-55E60	2
3	F11103-150	2

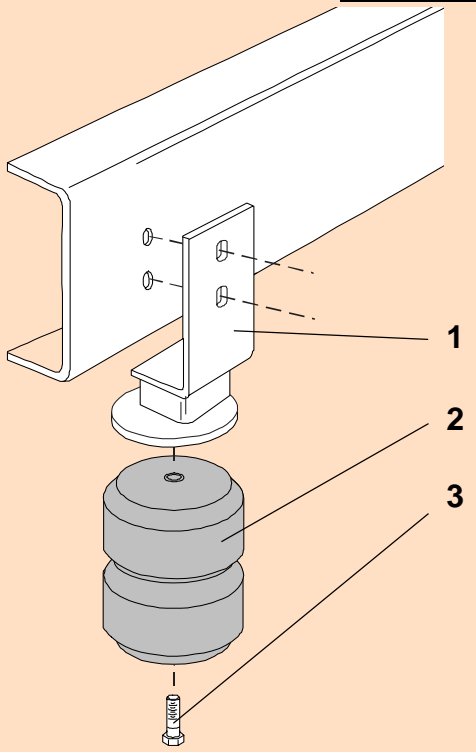

## FFFL80A

PART NUMBER	DESCRIPTION	QTY	LOCATION
<b>F11103-150</b>	HCS 1/2 x 1-3/4 UNF GR 5 Z	<b>2</b>	<b>G1D</b>
<b>A00535-55E60</b>	Hollow Rubber Spring	<b>2</b>	<b>C7A</b>
<b>K10325LH-003</b>	FFFL80A WELDMENT LH PAINTED	<b>1</b>	<b>D8D</b>
<b>K10325RH-003</b>	FFFL80A WELDMENT RH PAINTED	<b>1</b>	<b>D8D</b>
<b>B90224</b>	12 x 11 x 8-1/2" DW Carton	<b>1</b>	<b>A1A</b>
<b>B10100</b>	NEWSPRINT 18" ROLL	<b>1</b>	
<b>B00029-010</b>	BARCODE LABEL FOR KIT	<b>1</b>	

### ASSEMBLY NOTES:

**APPLY 'LEFT' LABEL TO L/H BRACKET.**

### Clearance Instructions:

Rear SES Kits for Pick-Ups and Vans should have a 1/2" to 1-1/2" gap between the rubber spring and contact point when empty.

A partial load, or vehicle accessories will reduce or eliminate the gap.

Front SES kits are usually in full contact.

Medium and Heavy-Duty Trucks, Trailers and Motorhomes will be in constant contact, and have no gap.