

FFFL80HD

FREIGHTLINER

Front suspension package

INSTALLATION INSTRUCTIONS

- a) Raise vehicle allowing the axle to hang freely.
- b) Remove top shock mounting bolts.
- c) Assemble Aeon rubber spring and bracket as shown in the adjacent diagram.
- d) Mount Timbren spring assembly between shock mount bracket and chassis frame.
- e) Tighten using Timbren fasteners provided - torque to OEM specifications.
- f) Lower vehicle.

Do not exceed vehicle manufacturer's recommended axle weight rating. Check for AEON® interference with vehicle components - Under load AEON® will "expand" in diameter.

Ref. = Reference
Part = Part#.
Qty. = Quantity

Ref	Part	Qty
1	K10366-003	1L-1R
2	A00200-65Q30	2
3	F11064-250	4

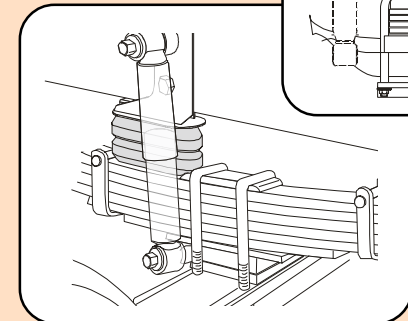
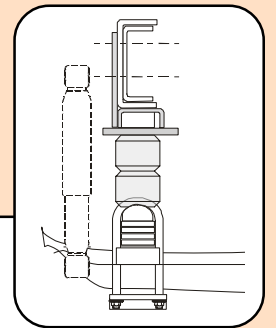
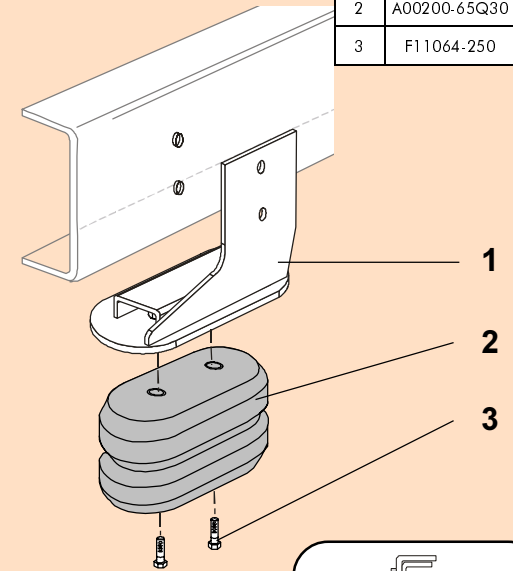

FFFL80HD

PART NUMBER	DESCRIPTION	QTY	LOCATION
F11064-250	HCS 3/8 x 1-3/4 UNC GR 5 Z	4	G3D
A00200-65Q30	Hollow Rubber Spring	2	C17B
K10366LH-003	FFFL80HD WELDMENT PAINTED	1	D18A
K10366RH-003	FFFL80HD WELDMENT PAINTED	1	D18A
B90224	12 x 11 x 8-1/2" DW Carton	1	A1A
B10100	NEWSPRINT 18" ROLL	1	
B00029-010	BARCODE LABEL FOR KIT	1	

ASSEMBLY NOTES:

APPLY 'LEFT' LABEL TO L/H BRACKET.

Clearance Instructions:

Rear SES Kits for Pick-Ups and Vans should have a 1/2" to 1-1/2" gap between the rubber spring and contact point when empty.

A partial load, or vehicle accessories will reduce or eliminate the gap.

Front SES kits are usually in full contact.

Medium and Heavy-Duty Trucks, Trailers and Motorhomes will be in constant contact, and have no gap.