

# FFFLD120

# FREIGHTLINER

Front suspension package

## INSTALLATION INSTRUCTIONS

- Raise vehicle allowing the axle to hang freely.
- Remove top shock mounting bolts.
- Assemble Aeon rubber spring and bracket as shown in the adjacent diagram.
- Mount Timbren spring assembly between shock mount bracket and chassis frame.
- Tighten using Timbren fasteners provided - torque to OEM specifications.
- Lower vehicle.

### NOTES:

Check for adequate clearance between starter & Timbren bracket.

Do not exceed vehicle manufacturer's recommended axle weight rating. Check for AEON<sup>®</sup> interference with vehicle components - Under load AEON<sup>®</sup> will "expand" in diameter.

Ref. = Reference  
Part = Part #.  
Qty. = Quantity

Ref	Part	Qty
1	F31007-150	6
2	F40071-020	6
3	F11146-150	6
4	K10278-003	1L-1R
5	A00200-65E60	2
6	F11104-150	4

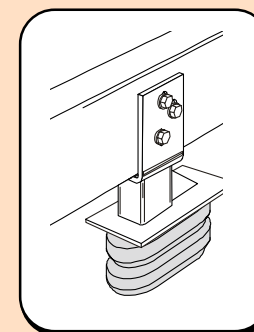
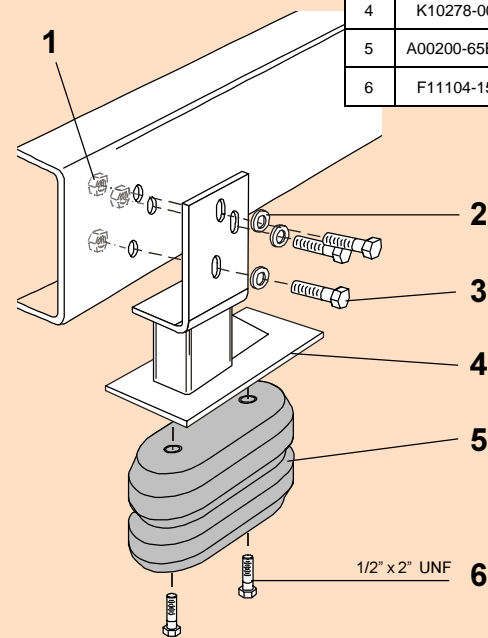

FFFLD120



## FFFLD120

PART NUMBER	DESCRIPTION	QTY	LOCATION
<b>F31007-150</b>	NYLOCK LOCKNUT 5/8 UNF GR 5 Z	<b>6</b>	<b>H2E</b>
<b>F40071-020</b>	WASHER FLAT USS 5/8 x 1-3/4 GR 2 Z	<b>6</b>	<b>H2E</b>
<b>F11146-150</b>	HCS 5/8 x 2-1/2 UNF GR 5 Z	<b>6</b>	<b>H2E</b>
<b>F11104-150</b>	HCS 1/2 x 2 UNF GR 5 Z	<b>4</b>	<b>G1D</b>
<b>A00200-65E60</b>	Hollow Rubber Spring	<b>2</b>	<b>C17B</b>
<b>K10278LH-003</b>	FFFLD120 WELDMENT LH PAINTED	<b>1</b>	<b>E3C</b>
<b>K10278RH-003</b>	FFFLD120 WELDMENT RH PAINTED	<b>1</b>	<b>E3C</b>
<b>B90203</b>	#175 BOX - 16 x 9-1/2 x 7	<b>1</b>	<b>A3A</b>
<b>B10100</b>	NEWSPRINT 18" ROLL	<b>1</b>	
<b>B00029-010</b>	BARCODE LABEL FOR KIT	<b>1</b>	

### ASSEMBLY NOTES:

APPLY 'LEFT' LABEL TO L/H BRACKET.

### Clearance Instructions:

Rear SES Kits for Pick-Ups and Vans should have a 1/2" to 1-1/2" gap between the rubber spring and contact point when empty.

A partial load, or vehicle accessories will reduce or eliminate the gap.

Front SES kits are usually in full contact.

Medium and Heavy-Duty Trucks, Trailers and Motorhomes will be in constant contact, and have no gap.