

# FFM2

## FREIGHTLINER

Front suspension package

### INSTALLATION INSTRUCTIONS

- a) Partially raise vehicle not allowing the axle to hang freely.
- b) Assemble Aeon rubber spring and bracket #2 as shown in the adjacent diagram.
- c) Mount Timbren assembly using existing holes & Timbren supplied fasteners.
- d) Loosen axle U-bolts
- e) Mount Timbren bracket #5 to axle & retighten U-bolts as per OEM instructions
- f) Lower vehicle.

*Do not exceed vehicle manufacturer's recommended axle weight rating. Check for AEON® interference with vehicle components - Under load AEON® will "expand" in diameter.*

**Ref.** = Reference  
**Part** = Part #.  
**Qty.** = Quantity

Ref	Part	Qty
1	F11104-150	2
2	K10425-003	1
3	A00560-75C70	1
4	F11106-150	1
5	K10450-003	1
6	F31005-150	2
7	F40052-020	2

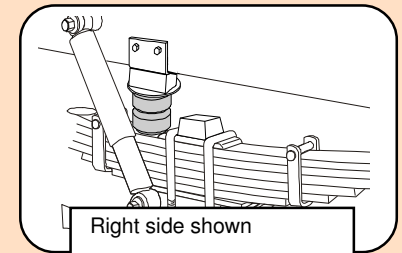
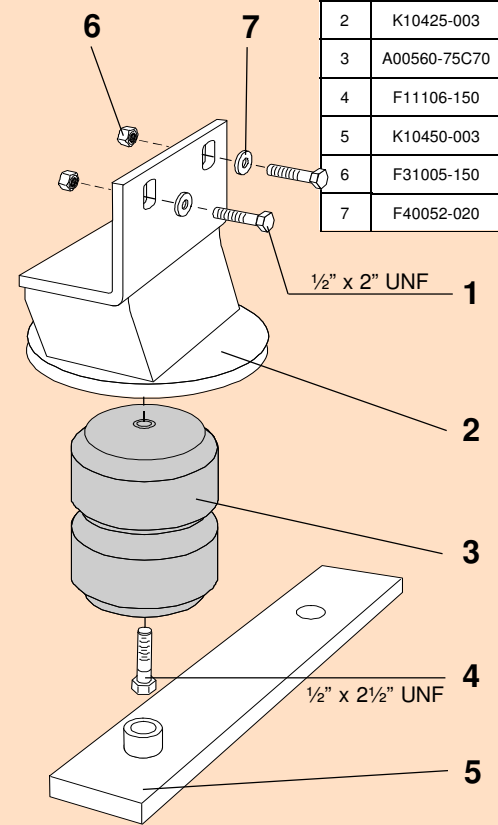

## FFM2

PART NUMBER	DESCRIPTION	QTY	LOCATION
<b>F31005-150</b>	NYLOCK LOCKNUT 1/2 UNF GR 5 Z	<b>2</b>	<b>G1D</b>
<b>F40052-020</b>	WASHER FLAT USS 1/2 x 1-3/8 GR 2 Z	<b>2</b>	<b>G1D</b>
<b>F11104-150</b>	HCS 1/2 x 2 UNF GR 5 Z	<b>2</b>	<b>G1D</b>
<b>F11106-150</b>	HCS 1/2 x 2-1/2 UNF GR 5 Z	<b>1</b>	<b>G1D</b>
<b>A00560-75C70</b>	Hollow Rubber Spring	<b>1</b>	<b>C12A</b>
<b>K10425-003</b>	FFM2 / STFL8500 WELDMENT - PAINTED	<b>1</b>	<b>D14C</b>
<b>K10450-003</b>	AEON LOCATOR FOR KIT FFM2 (PAINTED)	<b>1</b>	<b>E4C</b>
<b>B90223</b>	10-3/4 x 9-1/2 x 7 DW Carton	<b>1</b>	<b>A1A</b>
<b>B10100</b>	NEWSPRINT 18" ROLL	<b>1</b>	
<b>B00029-010</b>	BARCODE LABEL FOR KIT	<b>1</b>	

### Clearance Instructions:

Rear SES Kits for Pick-Ups and Vans should have a 1/2" to 1-1/2" gap between the rubber spring and contact point when empty.

A partial load, or vehicle accessories will reduce or eliminate the gap.

Front SES kits are usually in full contact.

Medium and Heavy-Duty Trucks, Trailers and Motorhomes will be in constant contact, and have no gap.