

FR750M

INSTALLATION INSTRUCTIONS

- Raise vehicle allowing the axle to hang freely.
- Remove existing bump stop assembly.
- Assemble Aeon rubber spring and bracket as shown in the adjacent diagram.
- Mount Timbren assembly using existing holes & Timbren supplied fasteners.
- Lower vehicle.

Do not exceed vehicle manufacturer's recommended axle weight rating. Check for AEON® interference with vehicle components - Under load AEON® will "expand" in diameter.

Ref. = Reference
Part = Part #.
Qty. = Quantity

Ref	Part	Qty
1	F31003-150	4
2	F40031-020	4
3	F11063-150	4
4	K10364-003	2
5	A00200-65E60	2
6	F11103-150	4

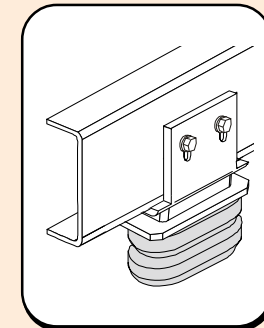
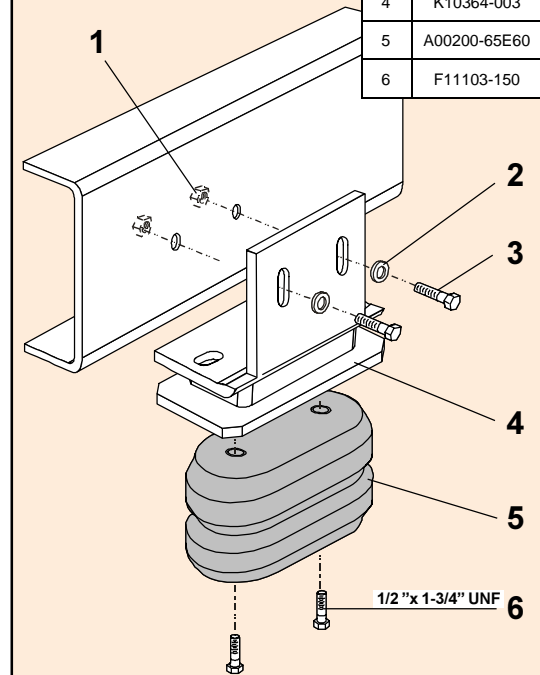

FR750M



FR750M

PART NUMBER	DESCRIPTION	QTY	LOCATION
F31003-150	NYLOCK LOCKNUT 3/8 UNF GR 5 Z	4	G1C
F40031-020	WASHER FLAT USS 3/8 x 1 GR 2 Z	4	G1C
F11063-150	HCS 3/8 x 1-1/2 UNF GR 5 Z	4	G1C
F11103-150	HCS 1/2 x 1-3/4 UNF GR 5 Z	4	G1D
A00200-65E60	Hollow Rubber Spring	2	C17B
K10364-003	FR750M WELDMENT PAINTED	2	D4E
B90223	10-3/4 x 9-1/2 x 7 DW Carton	1	A1A
B10100	NEWSPRINT 18" ROLL	1	
B00029-010	BARCODE LABEL FOR KIT	1	

Clearance Instructions:

Rear SES Kits for Pick-Ups and Vans should have a 1/2" to 1-1/2" gap between the rubber spring and contact point when empty.

A partial load, or vehicle accessories will reduce or eliminate the gap.

Front SES kits are usually in full contact.

Medium and Heavy-Duty Trucks, Trailers and Motorhomes will be in constant contact, and have no gap.