

FRMT45

FREIGHTNINER

INSTALLATION INSTRUCTIONS

- Raise vehicle allowing the axle to hang freely.
- Remove existing bump stop assembly.
- Assemble Aeon rubber spring and bracket as shown in the adjacent diagram.
- Mount Timbren assembly using existing holes & Timbren supplied fasteners.
- Lower vehicle.

NOTES:

If necessary, drill frame to ensure that Aeon spring is centered over axle. Always refer to and follow the vehicle manufacturer's guidelines when welding or drilling during installation of this kit.

Do not exceed vehicle manufacturer's recommended axle weight rating. Check for AEON® interference with vehicle components - Under load AEON® will "expand" in diameter.

Ref. = Reference
Part = Part #.
Qty. = Quantity

Ref	Part	Qty
1	F31005-150	2
2	F40052-020	4
3	F12104-253	2
4	F11103-150	2
5	K51318-003	2
6	A16120-003	2
7	A00540-75E60	2
8	F31005-250	2

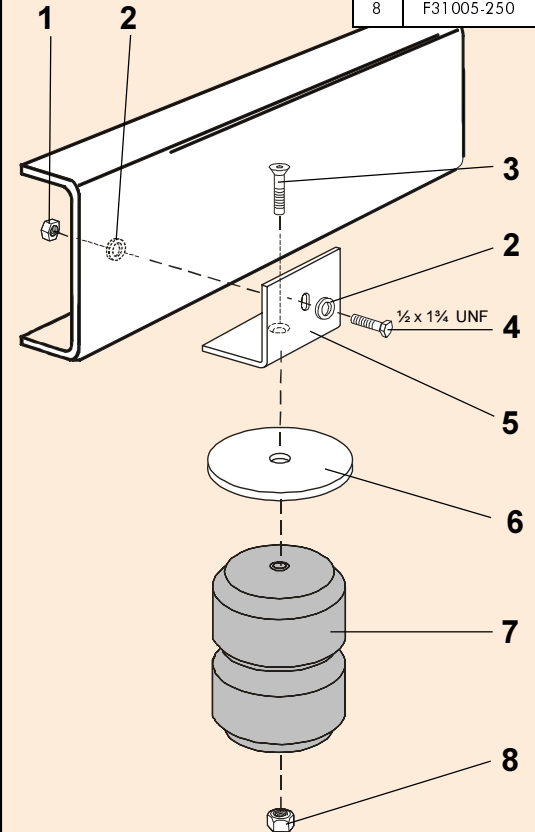

FRMT45

PART NUMBER	DESCRIPTION	QTY	LOCATION
F31005-150	NYLOCK LOCKNUT 1/2 UNF GR 5 Z	2	G1D
F40052-020	WASHER FLAT USS 1/2 x 1-3/8 GR 2 Z	4	G1D
F11103-150	HCS 1/2 x 1-3/4 UNF GR 5 Z	2	G1D
F31005-250	NYLOCK LOCKNUT 1/2 UNC GR 5 Z	2	G1B
F12104-253	FHSCS 1/2 x 2 UNC GR 5 B	2	J2C
A00540-75E60	Hollow Rubber Spring	2	C8A
K51318-003	FRMT45 BRACKET PAINTED	2	E2D
A16120-003	DISC 4 OD x 17/32 ID x 3/16 THK PAINTED	2	D20B
B90200-CR	SMALL REAR BOX - 9.5 x 7 x 5.5	1	A--E
B10000	8" x 12" BUBBLE FOR KITS	1	
B00029-010	BARCODE LABEL FOR KIT	1	

Clearance Instructions:

Rear SES Kits for Pick-Ups and Vans should have a 1/2" to 1-1/2" gap between the rubber spring and contact point when empty.

A partial load, or vehicle accessories will reduce or eliminate the gap.

Front SES kits are usually in full contact.

Medium and Heavy-Duty Trucks, Trailers and Motorhomes will be in constant contact, and have no gap.