

IHFTR2

INTERNATIONAL

Front suspension package

INSTALLATION INSTRUCTIONS

- a) Raise vehicle allowing the axle to hang freely.
- b) Remove OEM frame bracket and retain fasteners.
- c) Assemble Aeon rubber spring and bracket as shown in the adjacent diagram.
- d) Mount Timbren assembly using OEM fasteners.
- e) Follow OEM guidelines ensuring a non-permanent threadlocker such as Loctite 242 is used when replacing OEM bolts.
- f) Lower vehicle.

Do not exceed vehicle manufacturer's recommended axle weight rating. Check for AEON® interference with vehicle components - Under load AEON® will "expand" in diameter.

Ref. = Reference
Part = Part #.
Qty. = Quantity

Ref	Part	Qty
1	OEM	-
2	K10544-003	2
3	F11106-150	2
4	A01525-65G70	2
5	F31005-150	2

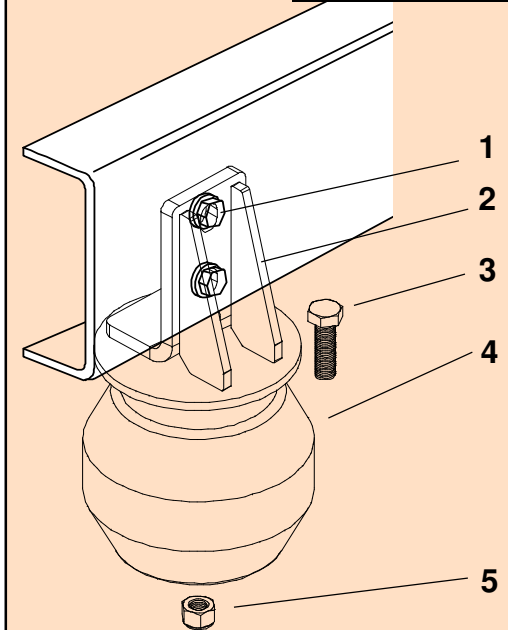

IHFTER2

PART NUMBER	DESCRIPTION	QTY	LOCATION
F31005-150	NYLOCK LOCKNUT 1/2 UNF GR 5 Z	2	G1D
F11106-150	HCS 1/2 x 2-1/2 UNF GR 5 Z	2	G1D
A01525-65G70	Hollow Rubber Spring	2	C18B
K10544-003	IHFTER2 WELDMENT PAINTED	2	D6C
B90223	10-3/4 x 9-1/2 x 7 DW Carton	1	A1A
B10100	NEWSPRINT 18" ROLL	1	
B00029-010	BARCODE LABEL FOR KIT	1	

Issued: 4/16/2015

Clearance Instructions:

Rear SES Kits for Pick-Ups and Vans should have a 1/2" to 1-1/2" gap between the rubber spring and contact point when empty.

A partial load, or vehicle accessories will reduce or eliminate the gap.

Front SES kits are usually in full contact.

Medium and Heavy-Duty Trucks, Trailers and Motorhomes will be in constant contact, and have no gap.