

IHRCXT

International 7400 CXT

Rear suspension package

INSTALLATION INSTRUCTIONS

- Raise vehicle allowing the axle to hang freely.
- Assemble Aeon rubber spring and bracket as shown in the adjacent diagram.
- Using holes in bracket as a template, drill through side of chassis frame rail making sure that Aeon rubber spring is centered over axle.
- Bolt Timbren assembly to the frame using existing holes where possible.
- Lower vehicle.

Do not exceed vehicle manufacturer's recommended axle weight rating. Check for AEON® interference with vehicle components - Under load AEON® will "expand" in diameter.

Ref. = Reference
Part = Part #.
Qty. = Quantity

Ref	Part	Qty
1	F31007-150	4
2	F40071-020	4
3	F11108-150	2
4	K10006-003	1L-1R
5	F11142-150	4
6	A1610B-003	2
7	A00560-65C70	2
8	F31005-150	2

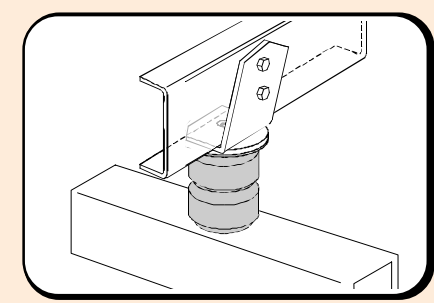
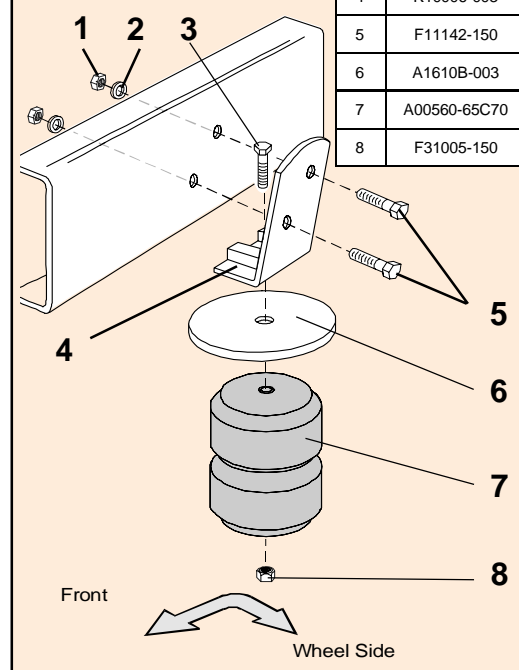

IHRCXT



IHRCXT

PART NUMBER	DESCRIPTION	QTY	LOCATION
F31007-150	NYLOCK LOCKNUT 5/8 UNF GR 5 Z	4	H2E
F40071-020	WASHER FLAT USS 5/8 x 1-3/4 GR 2 Z	4	H2E
F11142-150	HCS 5/8 x 1-1/2 UNF GR 5 Z	4	H2E
F31005-150	NYLOCK LOCKNUT 1/2 UNF GR 5 Z	2	G1D
F11108-150	HCS 1/2 x 3 UNF GR 5 Z	2	G2A
A00560-65C70	Hollow Rubber Spring	2	C12B
K10006LH-003	IHRCXT / MKT001 / MKTT001 WELD. LH PAINTED	1	E1A
K10006RH-003	IHRCXT/MKT001/MKTT001 WELD. RH PAINTED	1	E1A
A1610B-003	WASHER 4-1/2 OD x 17/32 ID x 1/4 THK PTD.	2	D20A
B90223	10-3/4 x 9-1/2 x 7 DW Carton	1	A1A
B10100	NEWSPRINT 18" ROLL	1	
B00029-010	BARCODE LABEL FOR KIT	1	

Clearance Instructions:

Rear SES Kits for Pick-Ups and Vans should have a 1/2" to 1-1/2" gap between the rubber spring and contact point when empty.

A partial load, or vehicle accessories will reduce or eliminate the gap.

Front SES kits are usually in full contact.

Medium and Heavy-Duty Trucks, Trailers and Motorhomes will be in constant contact, and have no gap.