

MFGR **MACK** Front suspension package

INSTALLATION INSTRUCTIONS

- a) Raise vehicle allowing the axle to hang freely.
- b) Remove existing bump stop located on U-bolt pad.
- c) Enlarge bump stop bracket hole by drilling to 17/32" diameter.
- d) Assemble Aeon rubber spring and metal plate as shown in the adjacent diagram.
- e) Mount Timbren assembly to bump stop bracket using existing holes & Timbren supplied fasteners.
- f) Lower vehicle.

Do not exceed vehicle manufacturer's recommended axle weight rating. Check for AEON® interference with vehicle components - Under load AEON® will "expand" in diameter.

Ref. = Reference
Part = Part #.
Qty. = Quantity

Ref	Part	Qty
1	F31005-250	4
2	A01525-75G70	2
3	K10386-003	2
4	F40052-020	2

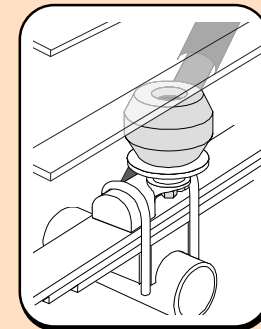
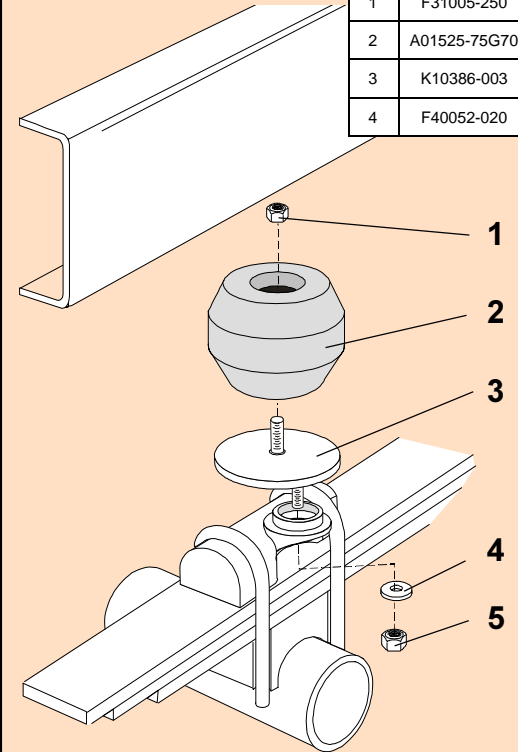

MFGR

PART NUMBER	DESCRIPTION	QTY	LOCATION
F31005-250	NYLOCK LOCKNUT 1/2 UNC GR 5 Z	4	G1B
F40052-020	WASHER FLAT USS 1/2 x 1-3/8 GR2 Z	2	G1D
A01525-75G70	Hollow Rubber Spring	2	C18A
K10386-003	MFGR WELDMENT	2	D1D
B90201-CF	LARGE FRONT BOX - 10.5 x 8.5 x 6	1	A--D
B10000	8" x 12" BUBBLE FOR KITS	1	
B00029-010	BARCODE LABEL FOR KIT	1	

Issued: 11/25/2003

Clearance Instructions:

Rear SES Kits for Pick-Ups and Vans should have a 1/2" to 1-1/2" gap between the rubber spring and contact point when empty.

A partial load, or vehicle accessories will reduce or eliminate the gap.

Front SES kits are usually in full contact.

Medium and Heavy-Duty Trucks, Trailers and Motorhomes will be in constant contact, and have no gap.