

MFGU7 **MACK** Front suspension package

INSTALLATION INSTRUCTIONS

- a) Raise vehicle allowing the axle to hang freely.
- b) Remove existing bump stop assembly.
- c) Assemble Aeon rubber spring and bracket as shown in the adjacent diagram.
- d) Mount Timbren upper assembly using existing holes & Timbren supplied fasteners.
- e) Remove existing bump stop located on U-bolt pad.
- f) Mount Timbren lower assembly to bump stop bracket using existing holes & Timbren supplied fasteners.
- g) Lower vehicle.

Do not exceed vehicle manufacturer's recommended axle weight rating. Check for AEON® interference with vehicle components - Under load AEON® will "expand" in diameter.

Ref. = Reference
Part = Part #.
Qty. = Quantity

Ref	Part	Qty
1	F31005-150	6
2	F12104-153	2
3	F40052-020	4
4	F11102-150	4
5	K51326-003	2
6	A0103B-75I4A	2
7	F12065-653	2
8	K54036-003	2
9	F40031-020	2
10	F31003-250	2

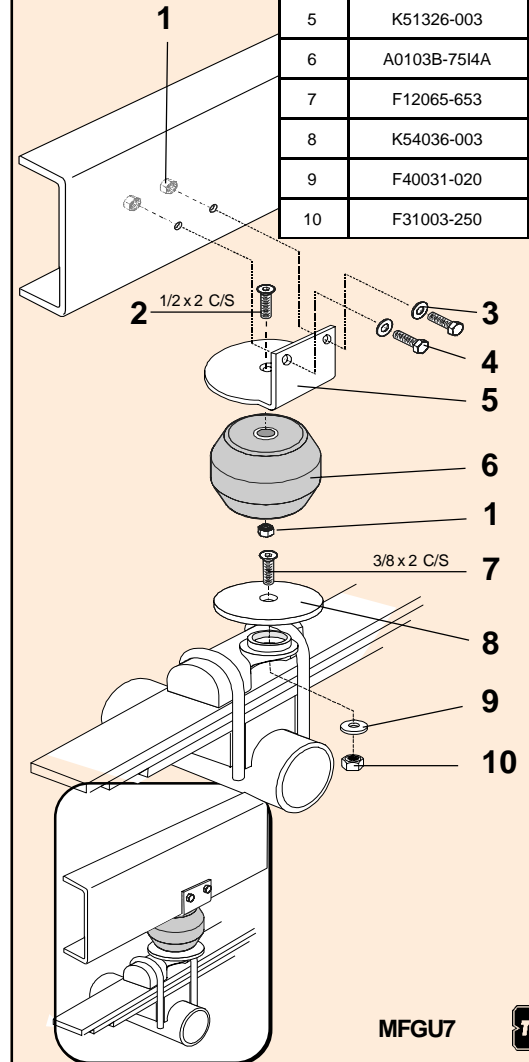

MFGU7

PART NUMBER	DESCRIPTION	QTY	LOCATION
F31003-250	NYLOCK LOCKNUT 3/8 UNC GR 5 Z	2	G1B
F40031-020	WASHER FLAT USS 3/8 x 1 GR 2 Z	2	G1C
F12065-653	FHSCS 3/8 x 2 F/T UNC GR 5 B	2	J2E
F31005-150	NYLOCK LOCKNUT 1/2 UNF GR 5 Z	6	G1D
F40052-020	WASHER FLAT USS 1/2 x 1-3/8 GR 2 Z	4	G1D
F11102-150	HCS 1/2 x 1-1/2 UNF GR 5 Z	4	G1D
F12104-153	FHSCS 1/2 x 2 UNF GR 5 B	2	J2D

A0103B-7514A	HOLLOW RUBBER SPRING	2	C1D
--------------	----------------------	---	-----

K51326-003	MFGU7 / MFGU7R FRAME BRACKET	2	D1E
K54036-003	DISC 1/4x4x13/32 C'SUNK PAINTED	2	D1E

B90200-CF	SMALL FRONT BOX - 9.5 x 7 x 5.5	1	A--E
B10000	8" x 12" BUBBLE FOR KITS	1	
B00029-010	BARCODE LABEL FOR KIT	1	

ASSEMBLY NOTES:

**NOTE: USE ARBOUR PRESS TO
#4 WASHERS INTO AEONS**

103B AEON With 'A' CORE.

Issued: 6/16/2009

Clearance Instructions:

Rear SES Kits for Pick-Ups and Vans should have a 1/2" to 1-1/2" gap between the rubber spring and contact point when empty.

A partial load, or vehicle accessories will reduce or eliminate the gap.

Front SES kits are usually in full contact.

Medium and Heavy-Duty Trucks, Trailers and Motorhomes will be in constant contact, and have no gap.