

# MFRD

Front suspension package

## INSTALLATION INSTRUCTIONS

- Partially raise vehicle not allowing the axle to hang freely.
- Remove existing bump stop located on U-bolt pad.
- Enlarge bump stop bracket hole by drilling to 17/32" diameter.
- Assemble Aeon rubber spring and metal plate as shown in the adjacent diagram.
- Mount Timbren assembly to bump stop bracket using existing holes & Timbren supplied fasteners.
- Lower vehicle.

*Do not exceed vehicle manufacturer's recommended axle weight rating. Check for AEON® interference with vehicle components - Under load AEON® will "expand" in diameter.*

**Ref.** = Reference  
**Part** = Part #.  
**Qty.** = Quantity

Ref	Part	Qty
1	F11106-150	2
2	A01525-75G70	2
3	A16110-003	2
4	F40052-020	2
5	F31005-150	2

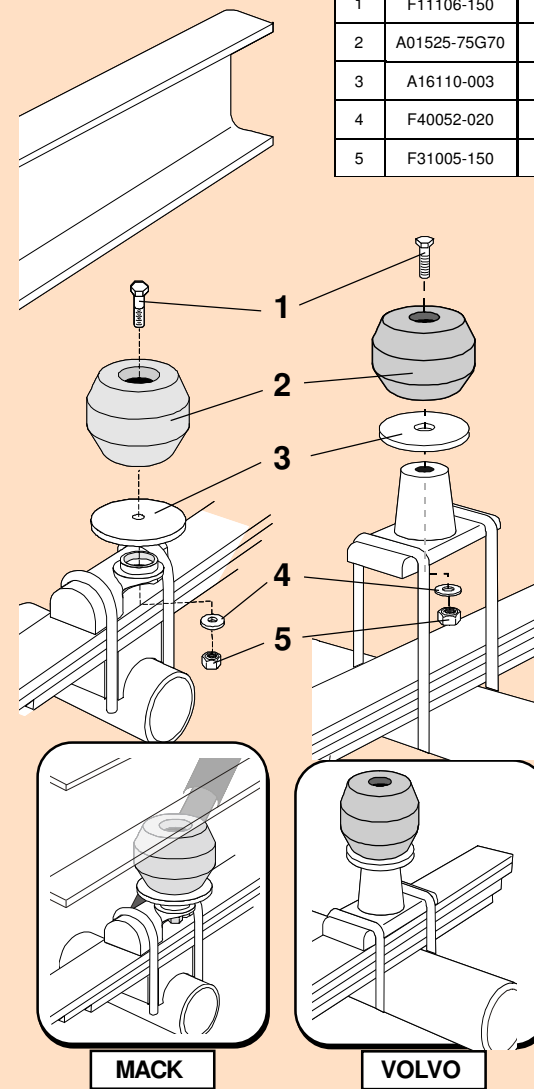

## MFRD

PART NUMBER	DESCRIPTION	QTY	LOCATION
<b>F31005-150</b>	NYLOCK LOCKNUT 1/2 UNF GR 5 Z	<b>2</b>	<b>G1D</b>
<b>F40052-020</b>	WASHER FLAT USS 1/2 x 1-3/8 GR 2 Z	<b>2</b>	<b>G1D</b>
<b>F11106-150</b>	HCS 1/2 x 2-1/2 UNF GR 5 Z	<b>2</b>	<b>G1D</b>
<b>A01525-75G70</b>	Hollow Rubber Spring	<b>2</b>	<b>C18A</b>
<b>A16110-003</b>	DISC 6 OD x 17/32 ID x 3/8 THK PAINTED	<b>2</b>	<b>D20A</b>
<b>B90201-CF</b>	LARGE FRONT BOX - 10.5 x 8.5 x 6	<b>1</b>	<b>A--D</b>
<b>B10000</b>	8" x 12" BUBBLE FOR KITS	<b>1</b>	
<b>B00029-010</b>	BARCODE LABEL FOR KIT	<b>1</b>	

Issued: 9/3/2013

### Clearance Instructions:

Rear SES Kits for Pick-Ups and Vans should have a 1/2" to 1-1/2" gap between the rubber spring and contact point when empty.

A partial load, or vehicle accessories will reduce or eliminate the gap.

Front SES kits are usually in full contact.

Medium and Heavy-Duty Trucks, Trailers and Motorhomes will be in constant contact, and have no gap.