

MFRFG **MITSUBISHI-FUSO** Rear suspension package

INSTALLATION INSTRUCTIONS

- a) Raise vehicle allowing the axle to hang freely.
- b) Remove existing bump stop assembly.
- c) Assemble Aeon rubber spring and bracket as shown in the adjacent diagram.
- d) Mount Timbren assembly using existing holes & Timbren supplied fasteners.
- e) Lower vehicle.

Ref. = Reference
Part = Part #.
Qty. = Quantity

| Ref | Part | Qty |
|-----|--------------|-----|
| 1 | F11538-350 | 4 |
| 2 | K10079-003 | 2 |
| 3 | F40310-020 | 4 |
| 4 | F31051-350 | 4 |
| 5 | A00540-65E60 | 2 |
| 6 | F11103-150 | 2 |

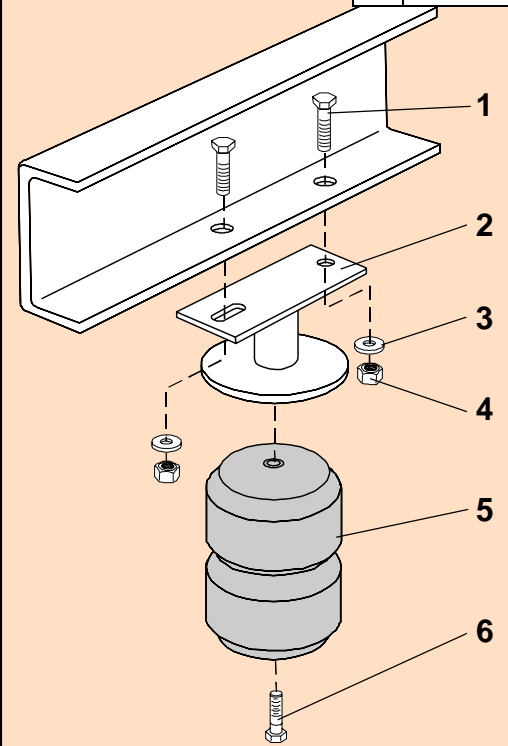

Do not exceed vehicle manufacturer's recommended axle weight rating. Check for AEON[®] interference with vehicle components - Under load AEON[®] will "expand" in diameter.

MFRFG

| PART NUMBER | DESCRIPTION | QTY | LOCATION |
|---------------------|------------------------------------|----------|-------------|
| F31051-350 | NYLOCK LOCKNUT M10 x 1.50 Gr 8.0 Z | 4 | I1D |
| F40310-020 | WASHER FLAT M10 GR 4.6 Z | 4 | I1D |
| F11538-350 | HCS M10 x 40 x 1.5 Gr 8.8 Z | 4 | I1C |
| F11103-150 | HCS 1/2 x 1-3/4 UNF GR 5 Z | 2 | G1D |
| | | | |
| A00540-65E60 | Hollow Rubber Spring | 2 | C8B |
| | | | |
| K10079-003 | MFRFG WELDMENT PAINTED | 2 | E1B |
| | | | |
| B90201-CR | LARGE REAR BOX - 10.5 x 8.5 x 6 | 1 | A--D |
| B10200 | 8" x 12" BUBBLE FOR KITS | 1 | |
| B00029-010 | BARCODE LABEL FOR KIT | 1 | |

Issued: 12/3/2009

Clearance Instructions:

Rear SES Kits for Pick-Ups and Vans should have a 1/2" to 1-1/2" gap between the rubber spring and contact point when empty.

A partial load, or vehicle accessories will reduce or eliminate the gap.

Front SES kits are usually in full contact.

Medium and Heavy-Duty Trucks, Trailers and Motorhomes will be in constant contact, and have no gap.