

# MFRFMMR

## MITSUBISHI-FUSO

Rear suspension package

### INSTALLATION INSTRUCTIONS

- a) Raise vehicle allowing the axle to hang freely.
- b) Remove existing bump stop assembly.
- c) Assemble Aeon rubber spring and bracket as shown in the adjacent diagram.
- d) Mount Timbren assembly using existing holes & Timbren supplied fasteners.
- e) Lower vehicle.

*Do not exceed vehicle manufacturer's recommended axle weight rating. Check for AEON® interference with vehicle components - Under load AEON® will "expand" in diameter.*

**Ref.** = Reference  
**Part** = Part #.  
**Qty.** = Quantity

Ref	Part	Qty
1	F31052-350	4
2	F40320-020	4
3	F11568-350	4
4	K10341-003	2
5	A0103B-65E00	2
6	F40053-020	2
7	F11103-150	2

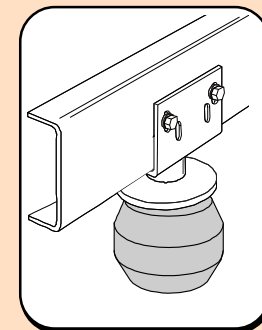
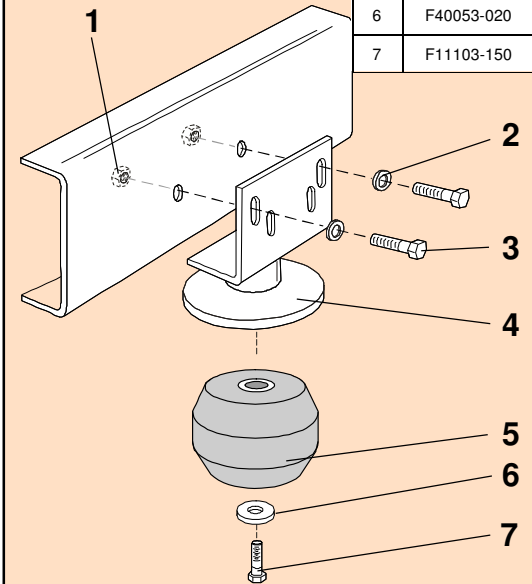

## MFRFMMR

PART NUMBER	DESCRIPTION	QTY	LOCATION
<b>F31052-350</b>	NYLOCK LOCKNUT M12 x 1.75 Gr 8.0 Z	<b>4</b>	<b>H3E</b>
<b>F40320-020</b>	WASHER FLAT M12 GR 4.6 Z	<b>4</b>	<b>H3E</b>
<b>F11568-350</b>	HCS M12 x 40 x 1.75 Gr 8.8 Z	<b>4</b>	<b>H3E</b>
<b>F11103-150</b>	HCS 1/2 x 1-3/4 UNF GR 5 Z	<b>2</b>	<b>G1D</b>
<b>F40053-020</b>	WASHER FLAT 1/2 x 1-1/2 GR 2 Z (#6)	<b>2</b>	<b>G4A</b>
<b>A0103B-65E00</b>	Hollow Rubber Spring	<b>2</b>	<b>C1B</b>
<b>K10341-003</b>	WELDMENT; PAINTED	<b>2</b>	<b>D14E</b>
<b>B90201-CR</b>	LARGE REAR BOX - 10.5 x 8.5 x 6	<b>1</b>	<b>A--D</b>
<b>B10000</b>	8" x 12" BUBBLE FOR KITS	<b>1</b>	
<b>B00029-010</b>	BARCODE LABEL FOR KIT	<b>1</b>	

### Clearance Instructions:

Rear SES Kits for Pick-Ups and Vans should have a 1/2" to 1-1/2" gap between the rubber spring and contact point when empty.

A partial load, or vehicle accessories will reduce or eliminate the gap.

Front SES kits are usually in full contact.

Medium and Heavy-Duty Trucks, Trailers and Motorhomes will be in constant contact, and have no gap.