

MKT001

MACK

Rear suspension package

INSTALLATION INSTRUCTIONS

- Raise vehicle allowing the axle to hang freely.
- Remove existing bump stop assembly.
- Assemble Aeon rubber spring and bracket as shown in the adjacent diagram.
- Mount Timbren assembly using existing holes & Timbren supplied fasteners.
- Lower vehicle.

Do not exceed vehicle manufacturer's recommended axle weight rating. Check for AEON® interference with vehicle components - Under load AEON® will "expand" in diameter.

Ref. = Reference
Part = Part #.
Qty. = Quantity

Ref	Part	Qty
1	F33007-150	8
2	F40071-020	8
3	F11108-150	4
4	K10006-003	2L-2R
5	F11142-150	8
6	A16110-003	4
7	A16040	4
8	A00560-55C70	4
9	F31005-150	4

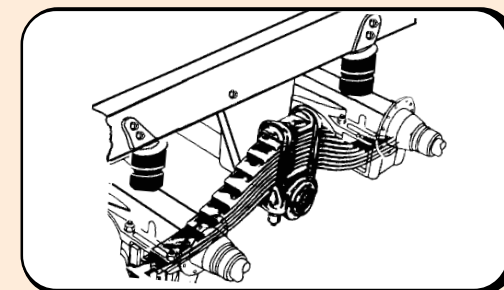
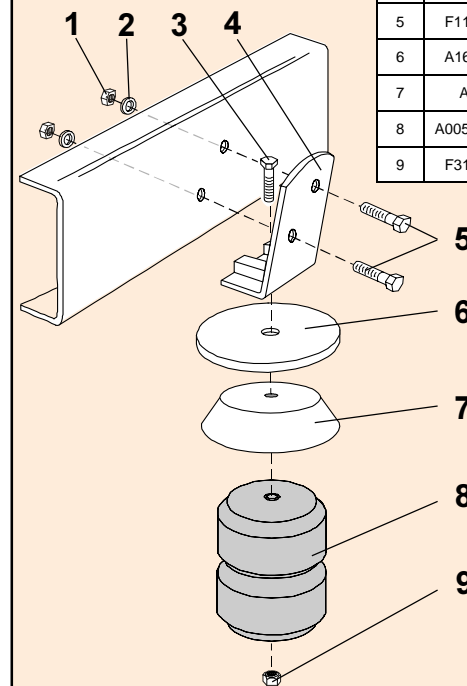

MKT001



MKT001

PART NUMBER	DESCRIPTION	QTY	LOCATION
F31007-150	NYLOCK LOCKNUT 5/8 UNF GR 5 Z	8	H2E
F40071-020	WASHER FLAT USS 5/8 x 1-3/4 GR 2 Z	8	H2E
F11142-150	HCS 5/8 x 1-1/2 UNF GR 5 Z	8	H2E
F31005-150	NYLOCK LOCKNUT 1/2 UNF GR 5 Z	4	G1D
F11108-150	HCS 1/2 x 3 UNF GR 5 Z	4	G2A

A00560-55C70	Hollow Rubber Spring	4	C13A
--------------	----------------------	---	------

K10006RH-003	IHRCXT/MKT001/MKTT001 WELD. RH PAINTED	2	E1A
K10006LH-003	IHRCXT / MKT001 / MKTT001 WELD. LH PAINTED	2	E1A
A16110-003	DISC 6 OD x 17/32 ID x 3/8 THK PAINTED	4	D20A
A16040	STEEL CUP 6-15/16 od x 17/32 id x 1-5/8" deep	4	D21B

B90223	10-3/4 x 9-1/2 x 7 DW Carton	2	A1A
B10100	NEWSPRINT 18" ROLL	1	
B00029-010	BARCODE LABEL FOR KIT	2	
	1 of 2 & 2 of 2 LABELS	1 ea.	

ASSEMBLY NOTES:

COMPONENTS ARE DIVIDED INTO LEFT / RIGHT AND PACKAGED IN SEPARATE CARTONS. IDENTIFY CARTONS AS LEFT OR RIGHT.

APPLY 'LEFT' LABEL TO L/H BRACKET.

APPLY "1 of 2" and "2 of 2" LABELS TO CARTONS

Issued: 9/9/2005

Clearance Instructions:

Rear SES Kits for Pick-Ups and Vans should have a 1/2" to 1-1/2" gap between the rubber spring and contact point when empty.

A partial load, or vehicle accessories will reduce or eliminate the gap.

Front SES kits are usually in full contact.

Medium and Heavy-Duty Trucks, Trailers and Motorhomes will be in constant contact, and have no gap.