

PR200

Rear suspension package

INSTALLATION INSTRUCTIONS

- Raise vehicle allowing the axle to hang freely.
- Remove existing bump stop assembly & retain fasteners.
- Assemble Aeon rubber spring and bracket as shown in the adjacent diagram.
- Mount Timbren assembly using OEM fasteners.
- Lower vehicle.

NOTES:

When removing OEM fasteners, use penetrating fluid.

Do not exceed vehicle manufacturer's recommended axle weight rating. Check for AEON[®] interference with vehicle components - Under load AEON[®] will "expand" in diameter.

Ref. = Reference
Part = Part #.
Qty. = Quantity

Ref	Part	Qty
1	K10237-003	2
2	A00540-75E60	2
3	F11103-150	2

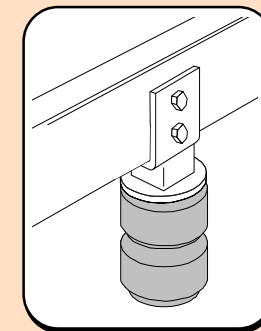
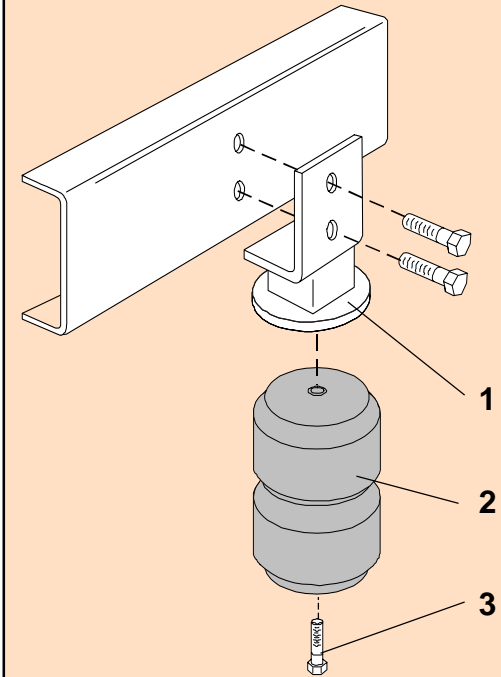

PR200



PR200

PART NUMBER	DESCRIPTION	QTY	LOCATION
F11103-150	HCS 1/2 x 1-3/4 UNF GR 5 Z	2	G1D
A00540-75E60	Hollow Rubber Spring	2	C8A
K10237-003	PR200 WELDMENT PAINTED	2	E3A
B90200-CR	SMALL REAR BOX - 9.5 x 7 x 5.5	1	A--E
B10000	8" x 12" BUBBLE FOR KITS	1	
B00029-010	BARCODE LABEL FOR KIT	1	

Issued: 11/2/2009

Clearance Instructions:

Rear SES Kits for Pick-Ups and Vans should have a 1/2" to 1-1/2" gap between the rubber spring and contact point when empty.

A partial load, or vehicle accessories will reduce or eliminate the gap.

Front SES kits are usually in full contact.

Medium and Heavy-Duty Trucks, Trailers and Motorhomes will be in constant contact, and have no gap.