

RESOS1

Rear suspension package

INSTALLATION INSTRUCTIONS

- With vehicle unloaded, locate Timbren frame bracket above U-bolt pad at measurement of 5" (see Diagram)
- Drill holes for Timbren bracket providing for at least four ½" Gr.8 bolts through the bracket & frame.
- Assemble Aeon spring to bracket as shown in adjacent diagram.
- Mount Timbren assembly to truck frame.

NOTES:

Holes in frame bracket must be within the gusset area.

SAFETY CAUTIONS

Ensure sufficient clearance between frame bracket & tire.

Always refer to and follow the vehicle manufacturer's guidelines when welding or drilling during installation of this kit.

Do not exceed vehicle manufacturer's recommended axle weight rating. Check for AEON® interference with vehicle components - Under load AEON® will "expand" in diameter.

Ref. = Reference
Part = Part #.
Qty. = Quantity

Ref	Part	Qty
1	F31005-150	2
2	F40052-020	2
3	K10064-003	2
4	A00540-65E60	2
5	F11104-150	2

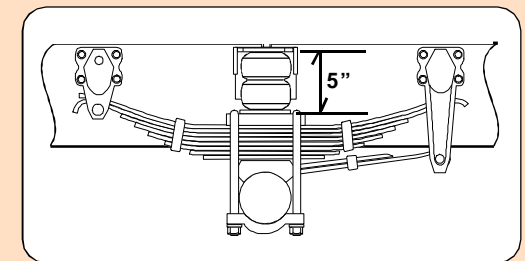
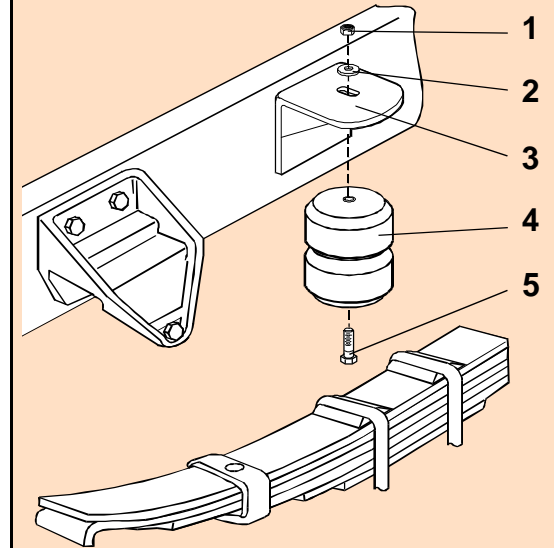

RESOS1



RESOS1

PART NUMBER	DESCRIPTION	QTY	LOCATION
F31005-150	NYLOCK LOCKNUT 1/2 UNF GR 5 Z	2	G1D
F40052-020	WASHER FLAT USS 1/2 x 1-3/8 GR 2 Z	2	G1D
F11104-150	HCS 1/2 x 2 UNF GR 5 Z	2	G1D
A00540-65E60	Hollow Rubber Spring	2	C8B
K10064-003	REDOS1 / RESOS1 WELDMENT PAINTED	2	D11E
B90211	#175 BOX - 10 x 8 x 5-1/2" c/w Timbren Logo	1	A6A
B10100	NEWSPRINT 18" ROLL	1	
B00029-010	BARCODE LABEL FOR KIT	1	

Issued: 4/27/2006

Clearance Instructions:

Rear SES Kits for Pick-Ups and Vans should have a 1/2" to 1-1/2" gap between the rubber spring and contact point when empty.

A partial load, or vehicle accessories will reduce or eliminate the gap.

Front SES kits are usually in full contact.

Medium and Heavy-Duty Trucks, Trailers and Motorhomes will be in constant contact, and have no gap.