

# STFL9500

## STERLING

Front suspension package

### INSTALLATION INSTRUCTIONS

- Raise vehicle allowing the axle to hang freely.
- Assemble Aeon rubber spring and bracket as shown in the adjacent diagram.
- Mount Timbren assembly using existing holes & Timbren supplied fasteners.
- Lower vehicle.

**Notes:**

If necessary, drill frame to ensure that Aeon spring is centered over leaf. Always refer to and follow the vehicle manufacturer's guidelines when welding or drilling during installation of this kit.

*Do not exceed vehicle manufacturer's recommended axle weight rating. Check for AEON<sup>®</sup> interference with vehicle components - Under load AEON<sup>®</sup> will "expand" in diameter.*

**Ref.** = Reference  
**Part** = Part #.  
**Qty.** = Quantity

Ref	Part	Qty
1	F31007-150	4
2	F40071-020	4
3	F11146-150	4
4	K10463-003	1L-1R
5	A00560-65C70	2
6	F11106-150	2

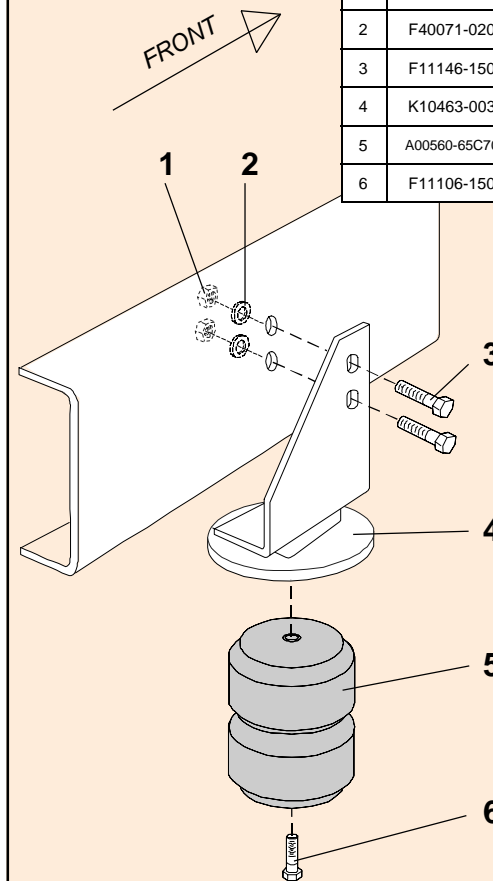

## STFL9500

PART NUMBER	DESCRIPTION	QTY	LOCATION
<b>F31007-150</b>	NYLOCK LOCKNUT 5/8 UNF GR 5 Z	4	H2E
<b>F40071-020</b>	WASHER FLAT USS 5/8 x 1-3/4 GR 2 Z	4	H2E
<b>F11146-150</b>	HCS 5/8 x 2-1/2 UNF GR 5 Z	4	H2E
<b>F11106-150</b>	HCS 1/2 x 2-1/2 UNF GR 5 Z	2	G1D
<b>A00560-65C70</b>	Hollow Rubber Spring	2	C12B
<b>K10463LH-003</b>	STFL9500 WELDMENT LH PAINTED	1	E4C
<b>K10463RH-003</b>	STFL9500 WELDMENT RH PAINTED	1	E4C
<b>B90213</b>	13 x 13 x 7 DW Carton	1	A4A
<b>B10100</b>	NEWSPRINT 18" ROLL	1	
<b>B00029-010</b>	BARCODE LABEL FOR KIT	1	

### ASSEMBLY NOTES:

APPLY 'LEFT' LABEL TO L/H BRACKET.

### Clearance Instructions:

Rear SES Kits for Pick-Ups and Vans should have a 1/2" to 1-1/2" gap between the rubber spring and contact point when empty.

A partial load, or vehicle accessories will reduce or eliminate the gap.

Front SES kits are usually in full contact.

Medium and Heavy-Duty Trucks, Trailers and Motorhomes will be in constant contact, and have no gap.