

# STFLT95A

# STERLING

Front suspension package

## INSTALLATION INSTRUCTIONS

- Raise vehicle allowing the axle to hang freely.
- Remove existing bump stop assembly.
- Assemble Aeon rubber spring and bracket as shown in the adjacent diagram.
- Mount Timbren assembly using existing holes & Timbren supplied fasteners.
- Lower vehicle.

*Do not exceed vehicle manufacturer's recommended axle weight rating. Check for AEON® interference with vehicle components - Under load AEON® will "expand" in diameter.*

**Ref.** = Reference  
**Part** = Part #.  
**Qty.** = Quantity

Ref	Part	Qty
1	F31005-150	4
2	F40052-020	4
3	K10336-003	2
4	F11102-150	4
5	A00200-65Q30	2
6	F11064-250	4

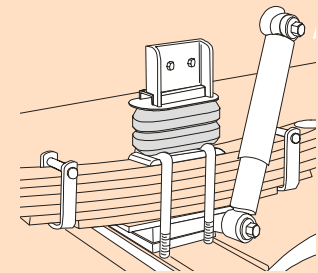
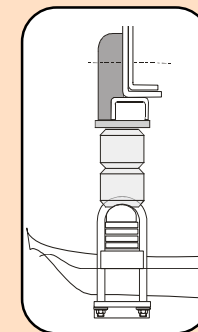
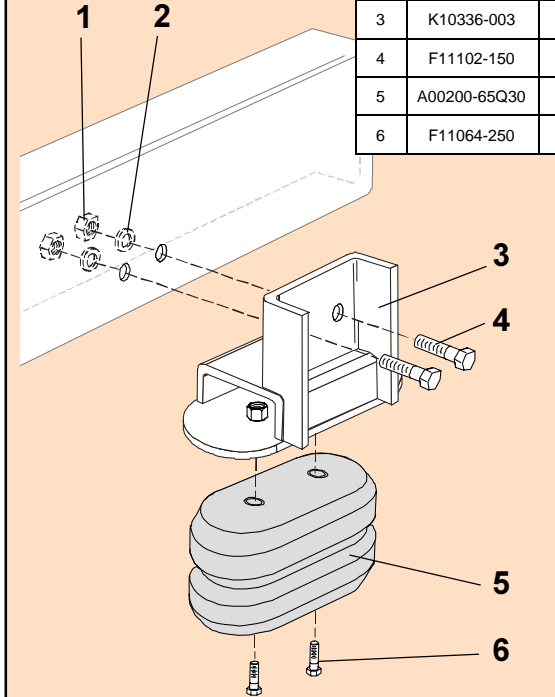

## STFLT95A

PART NUMBER	DESCRIPTION	QTY	LOCATION
<b>F31005-150</b>	NYLOCK LOCKNUT 1/2 UNF GR 5 Z	<b>4</b>	<b>G1D</b>
<b>F40052-020</b>	WASHER FLAT USS 1/2 x 1-3/8 GR 2 Z	<b>4</b>	<b>G1D</b>
<b>F11102-150</b>	HCS 1/2 x 1-1/2 UNF GR 5 Z	<b>4</b>	<b>G1D</b>
<b>F11064-250</b>	HCS 3/8 x 1-3/4 UNC GR 5 Z	<b>4</b>	<b>G3D</b>
<b>A00200-65Q30</b>	Hollow Rubber Spring	<b>2</b>	<b>C17B</b>
<b>K10336-003</b>	STFLT95 / 95A WELDMENT PAINTED	<b>2</b>	<b>D4E</b>
<b>B90223</b>	10-3/4 x 9-1/2 x 7 DW Carton	<b>1</b>	<b>A1A</b>
<b>B10100</b>	NEWSPRINT 18" ROLL	<b>1</b>	
<b>B00029-010</b>	BARCODE LABEL FOR KIT	<b>1</b>	

### Clearance Instructions:

Rear SES Kits for Pick-Ups and Vans should have a 1/2" to 1-1/2" gap between the rubber spring and contact point when empty.

A partial load, or vehicle accessories will reduce or eliminate the gap.

Front SES kits are usually in full contact.

Medium and Heavy-Duty Trucks, Trailers and Motorhomes will be in constant contact, and have no gap.