



THIS OPERATING MANUAL CONTAINS IMPORTANT SAFETY INFORMATION. READ CAREFULLY AND UNDERSTAND ALL INFORMATION BEFORE OPERATING TOOL. SAVE THIS MANUAL FOR FUTURE USE.

OPERATING INSTRUCTIONS AND PARTS BREAKDOWN

MODEL T83006

3 TON S.U.V. SERVICE JACK

PRIOR TO OPERATION

Air may become trapped in the hydraulic system during transit. To purge air:

1. Open release valve by turning handle counterclockwise.
2. Pump handle rapidly 4 full strokes. This will expel air that may have entered oil passages during transit.
3. Close release valve by rotating handle clockwise and pump handle.
4. If lift arm raised, jack is ready for use. If not, repeat this procedure.

OPERATING INSTRUCTIONS

IMPORTANT: Before attempting to raise a vehicle, check vehicle service manual for recommended lifting surfaces.

1. **To raise load:** Close release valve tightly (by turning handle clockwise) **DO NOT OVERTIGHTEN.** Position jack under load so that saddle will contact load firmly and load is centered so it cannot slip. Operate jack handle until saddle approaches the load. Once again check to see that saddle is correctly positioned. Raise load to desired height. Place jack stands of appropriate capacity under the vehicle. **DO NOT CRAWL UNDER VEHICLE WHILE LIFTING VEHICLE OR PLACING OR REMOVING JACK STANDS!** Place jack stands at vehicle manufacturer's recommended lift areas that provide stable support for the raised vehicle.
2. **To lower load:** Open release valve **VERY SLOWLY** (by turning handle counterclockwise). When release valve is opened, saddle and load will be lowered. Lower the vehicle slowly so as not to shock load the jack stands. Once repairs are completed, raise vehicle enough to remove jack stands. Lower vehicle very slowly.

CAUTION: Keep hands or feet away from the hinge mechanism of the jack.

⚠ WARNING



1. READ, STUDY, AND UNDERSTAND ALL WARNINGS AND OPERATING INSTRUCTIONS PRIOR TO USE.
2. DO NOT OVERLOAD THIS JACK BEYOND THE RATED CAPACITY.
3. THIS JACK IS DESIGNED FOR USE ONLY ON HARD LEVEL SURFACES CAPABLE OF SUSTAINING THE LOAD.
4. THIS IS A LIFTING DEVICE ONLY. THE LOAD MUST BE SUPPORTED IMMEDIATELY BY OTHER APPROPRIATE MEANS.
5. DO NOT MOVE OR DOLLY THE VEHICLE WHILE ON THE JACK.
6. LIFT ONLY ON AREAS OF THE VEHICLE AS SPECIFIED BY THE VEHICLE MANUFACTURER.
7. CENTER LOAD ON SADDLE PRIOR TO LIFTING.
8. SOME VEHICLES REQUIRE AN ADAPTER TO PROPERLY ENGAGE THE FRAME FOR LIFTING. USE VEHICLE MANUFACTURERS INSTRUCTIONS ON PROPER LIFTING.
9. NO ALTERATIONS TO THE JACK SHALL BE MADE.
10. FAILURE TO HEED THESE WARNINGS MAY RESULT IN PERSONAL INJURY AND/OR PROPERTY DAMAGE.

⚠ WARNING

FOR YOUR SAFETY AND TO PREVENT INJURY:



Use Service Jack for lifting purposes ONLY.

Always support vehicle with jack stands.



3 TON S.U.V. SERVICE JACK

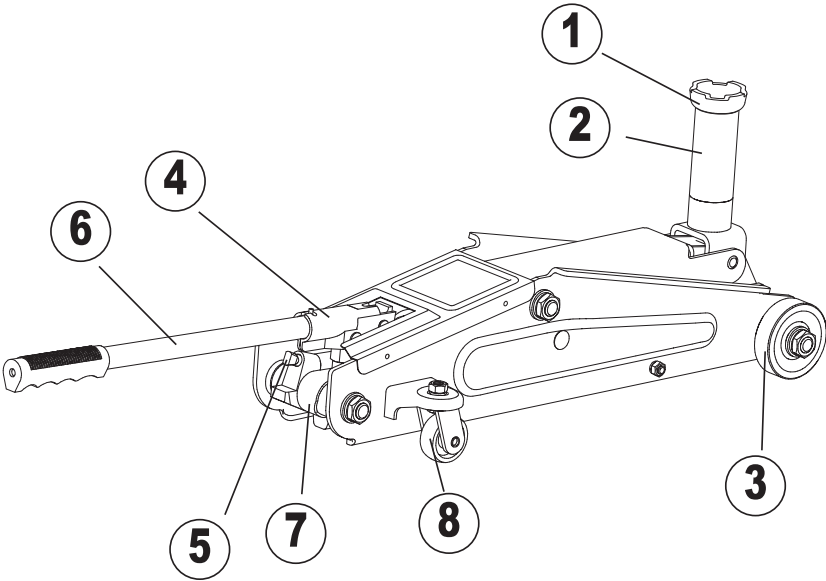

ITEM NO.	DESCRIPTION
1	Saddle
2	SUV Saddle
3	Front Wheel Assembly
4	Handle Fork
5	Release Valve
6	Handle Assembly
7	Power Unit Assembly
8	Rear Caster Assembly

INSPECTION

Visual inspection should be made before each use of the jack, checking for leaking hydraulic fluid and damaged, loose or missing parts. Each jack must be inspected by a manufacturer's repair facility immediately, if subjected to an abnormal load or shock. Any jack which appears to be damaged in any way, found to be badly worn, or operates abnormally **MUST BE REMOVED FROM SERVICE** until necessary repairs are made by a manufacturer's authorized repair facility. It is recommended that an annual inspection of the jack be made by a manufacturer's authorized repair facility and that any defective parts, decals or warning labels be replaced with manufacturer's specified parts.

A list of authorized repair facilities is available from the manufacturer.

LUBRICATION

All moving joints require lubrication often. Oil all lift arm linkages, front wheels and rear casters.

OWNER/USER RESPONSIBILITY

The owner and/or user must have a thorough understanding of the manufacturer's operating instructions and warnings before using this jack. Personnel involved in the use and operation of equipment shall be careful, competent, trained, and qualified in the safe operation of the equipment and its proper use when servicing motor vehicles and their components. Warning information should be emphasized and understood. If the operator is not fluent in English, the manufacturer's instructions and warning shall be read to and discussed with the operator in the operator's native language by the purchaser/ owner, making sure that the operator comprehends its contents.

Owner and/or user must study and maintain for future reference the manufacturer's instructions. Owner and/or user is responsible for keeping all warning labels and instruction manuals legible and intact. Replacement labels and literature are available from the manufacturer.

MAINTENANCE

IMPORTANT: When adding or replacing oil, always use a quality hydraulic oil. DO NOT use brake fluid, transmission fluid, alcohol, glycerine, detergent motor oil, or dirty oil as improper fluid can cause serious internal damage to jack.

To add oil: With saddle fully lowered and jack on level ground, remove filler plug (see Fig. 1). Oil should be filled to level of oil filler plug hole. If low, add oil as needed.

Maintenance and Inspection: The owner and/or user must maintain and inspect the jack in accordance with the manufacturer's instructions.

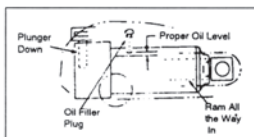

Fig. 1

SPECIFICATIONS

Low Height	5-7/8 inch
High Height	20-7/8 inch
Saddle Diameter	1-15/16 inch
Handle Length	24-1/2 inch
Base Length	24-7/8 inch
Chassis Width	9-1/2 inch

POSSIBLE PROBLEMS AND SOLUTIONS

PROBLEMS					SOLUTIONS
Jack will not lift load	Jack will not hold load or handle rises	Jack will not lift to its full height	Jack will not lower completely	Jack will not lift smoothly or jack feels spongy	
✓					The release valve is not closed. Turn the valve clockwise tightly.
✓		✓			Low on oil. Refill the jack to the correct level of oil.
✓					Pump seals and back-up ring is defective. Clean oil passages, replace seals and renew oil. (Must be serviced by qualified service center)
		✓		✓	The hydraulic system is filled with air. Open the release valve, pump handle rapidly (4) full strokes to purge air, close release valve.
			✓		Return spring is broken or linkages binding. Replace spring if broken. Grease pivot shaft, oil all lift arm linkages.
	✓				Discharge ball is not sealing hydraulic system and oil may be dirty. Manually flush hydraulic system by raising and lowering lift arm by hand. Open the release valve, as required to raise and lower the lift arm. Manually raise and lower lift arm.