

# **TORKLIFT** **INTERNATIONAL**

**OVER 35 YEARS OF INNOVATION, QUALITY, SAFETY.**

## **TRUE FRAME MOUNTED CAMPER TIE DOWNS**

**IMPORTANT OWNER-OPERATOR INSTALLATION INSTRUCTIONS**

**Part # C2214 Rev 2 :: C2219**

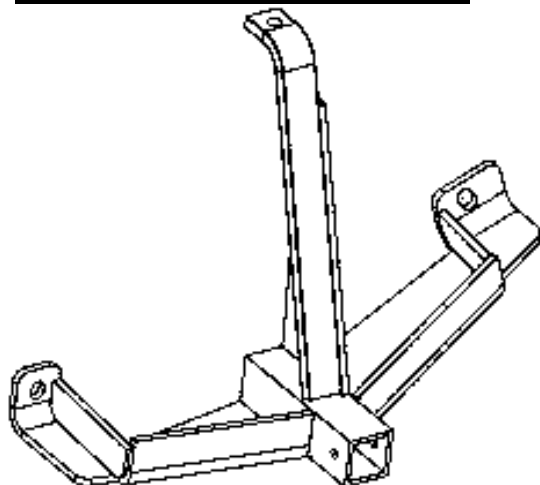

# Warnings

## Truck Bed and Camper Protection









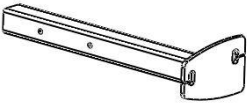

Torklift **does not** recommend installing your camper on top of a plastic bed liner (or other compressible material such as foam). These materials can act as a spring, causing increased vertical truck camper movement independent of the vehicle. Plastic bed liners can slide on the truck bed surface, and the truck camper can slide on top of the bed liner. Using a plastic bed liner or similar compressible material will void your warranty and may additionally cause truck bed and/or camper damage.

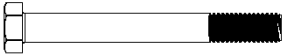
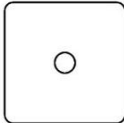
Minor movement or settling can occur in some incidental harsh driving conditions (on or off-road). A rubber bed mat is recommended to protect the truck bed and camper, but is not a requirement to maintain the Torklift legendary lifetime warranty.

## Suspension

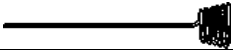
To significantly reduce body roll, sag and sway Torklift strongly recommends the StableLoad. Torklift International StableLoads improve safety, handling, and to help level your truck.

If your truck is additionally equipped with suspension air bags Torklift cautions against over pressurization as this may lead to unsafe vehicle handling characteristics. We have found that airbags used in conjunction with StableLoads have allowed operators to lower air bag pressure by 50% or more. Only pressurize suspension air bags enough to level the truck.

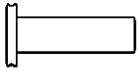
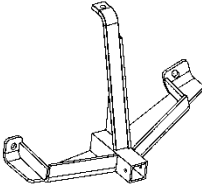
	Straight Tie-Down Insert	2
	7/16" x 2" Grade 8 Bolt	2
	1/2" x 5" Grade 5 Bolt	2
	3.5"(8.89cm) Sq Washer	2
	1"(2.54cm) x 2"(5.08cm) Plate Washer	2
	1/2" SAE Flat Washer	2
	7/16" USS Flat Washer	2
	1/2" Bolt Fisher	1
	1/2"-13 Serrated Grade 5 Nut	2
	7/16"-14 Grade 8 Nut	2
	1/2" Star Washer	2
	7/16" Lock Washer	2
	1/4" Snapper Pin	2
	<a href="#">Tie-Down</a>	2

**INSTALLATION INSTRUCTIONS: READ AND UNDERSTAND ALL INSTRUCTIONS BEFORE STARTING:**

**STEP 1**

**DRIVERS SIDE FIRST:** Locate and remove the forward most bolt attaching the bed to the truck frame.

**STEP 2**

Attach the supplied **1/2" bolt fisher** to the **7/16" x 2" Grade 8 Bolt**. Place the bolt into the slotted hole on the angled portion of the frame rearward of the bed mount. With the bolt inside of the frame, slide a **1/2" Star Washer** and **1" (2.54cm) x 2" (5.08cm) Plate Washer** onto the wire end of the **1/2" Bolt Fisher**, and slide them into the frame. (See figure 2.1) Leave the wire end of the **1/2" Bolt Fisher** outside of the frame.

**Figure 2.1**

Driver side shown.  
Remove this bolt.

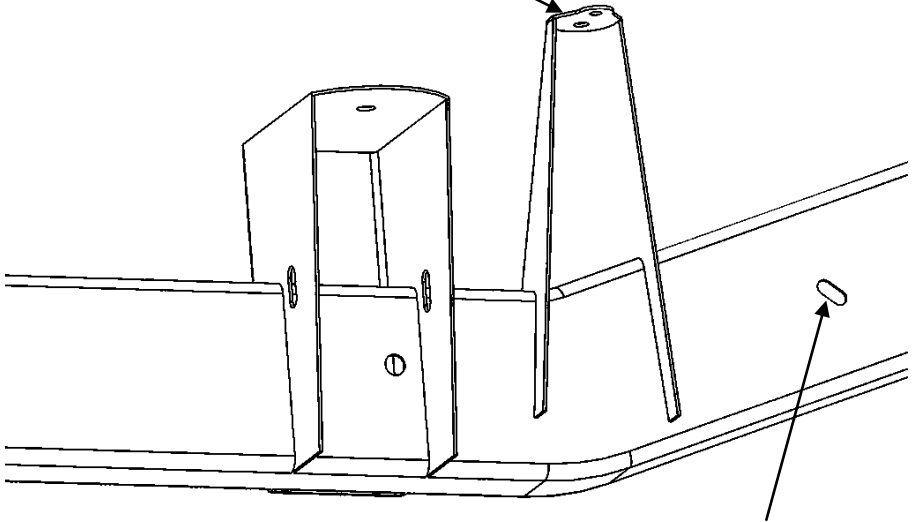

Fish bolt, star washer, and  
plate washer into this hole

### STEP 3

With the hardware in the frame, run the wire end of the **1/2" Bolt Fisher** through the slotted hole in the **Tie-Down**. Using the factory bolt removed in **Step 1**, bolt the upper hole of the **Tie-Down** into forward most bed mount. Leave loose at this time.

### STEP 4

Using the **1/2" Bolt Fisher**, pull the **7/16" x 2" Grade 8 Bolt** back through the **1/2" Star Washer**, **1" (2.54cm) x 2" (5.08cm) Plate Washer**, Truck Frame, and Tie-Down. Carefully hold the end of the bolt while disconnecting the bolt fisher from the **7/16" x 2" Grade 8 Bolt**. Loosely install a **7/16" USS Flat Washer**, **7/16" Lock Washer**, and a **7/16"-14 grade 8 nut**. Be careful not to drop the bolt back into the frame without the bolt fisher attached.

### STEP 5

Install a **1/2" x 5" Grade 5 Bolt** and **1/2" SAE Flat Washer** through the round hole in the Tie-Down and through the frame. Secure the threaded side of the bolt with a **3.5" (8.89cm) Sq Washer** and **1/2"-13 Serrated Grade 5 Nut**. (See Figure 5.1)

**Figure 5.1**

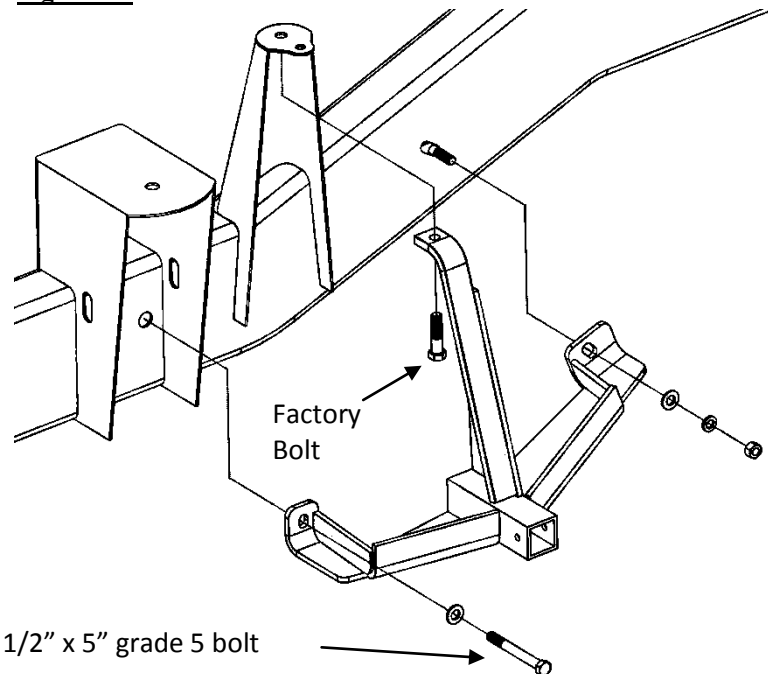

## STEP 6

Torque the 7/16" x 2" Grade 8 Bolt and the factory bed mounting bolt to **50 ft-lbs.(67 Nm)**

Torque the 1/2" x 5" Grade 5 Bolt to **30 ft-lbs.(40 Nm)**

## STEP 7

Install the driver side **Straight Tie-Down Insert** into the **Tie-Down** receiver tube. Secure the **Straight Tie-Down Insert** with the included **1/4" Snapper Pin**. Either of the holes in the insert can be used as long as there is enough clearance between the turnbuckles and the body of the truck.

## STEP 8

Repeat steps 1-7 on the passenger side of the truck.

## RECOMMENDED TRUCK CAMPER INSTALLATION INSTRUCTIONS

When securing any heavy load (especially a camper) in your truck bed, your front tie down points should pull the load forward as much as possible. Some camper anchor points may differ with different manufacturers, as well as the camper jack mounting locations. Your Torklift tie down inserts have offset triangular brackets to increase the angle of pull. These are designed to be used in the front facing forward, and the rear facing rearward but can be used in either front or rear. These recommendations are to be considered and followed as a basic rule of thumb. Obviously there will be some applications where this may not be possible. At a minimum, if opposite pull of both front and rear Tiedowns cannot be achieved for whatever reason, you should have at least a forward pull at the front or rear location. If your camper does not come with Rubber Bumpers on the front lower portion of the camper, installing Rubber Bumpers (Torklift has Rubber Bumpers available Part A7001) or using a block of wood such as a 2 x 4 in the bed, will prevent the camper from damaging the front bulk head of the truck bed. Minor movement (or settling) can occur in some incidental harsh driving conditions (on or off road). A rubber bed mat is not a requirement to maintain the lifetime warranty on a Torklift system, but a strong recommendation simply as a safety precaution to protect the truck bed, the bottom of the camper and to give the camper additional support.

**TORKLIFT DOES NOT RECOMMEND:** Installing your truck camper in your truck on top of a drop in plastic bed liner!!! The drop in plastic bed liners can slide on top of the truck bed surface, and the camper can slide on top of the slick surface of the bed liner. The liner can also act as a spring causing a trampoline effect increasing vertical truck camper movement, independent of the vehicle, possibly resulting in truck bed, and camper damage!

### INSTRUCTIONS FOR FINISH MAINTENANCE OF TORKLIFT PRODUCTS

#### **POWDER COATED STEEL:**

To keep your Torklift products looking good follow these guidelines. All steel powder coated Torklift products are sandblasted for maximum adhesion and use a high quality industrial urethane based powder coat. Due to the extreme, harsh, undercar environment that your Torklift products live in, (consistently sprayed with corrosive road chemicals such as salt, and road debris), Torklift does not warranty the powder coated finish.

To minimize corrosion from these factors on powder coated steel products, Torklift recommends regularly cleaning and inspecting the powder coated surface and touching up any affected areas with an enamel or urethane based aerosol paint product. If there are any areas of surface rust, there are also aerosol spray rust converters available on the market that can be used as a preparation to touch-up paint application. These finish maintenance products are available at any automotive parts supplier.

#### **POLISHED STAINLESS STEEL :**

TorkLift utilizes quality grade 304 stainless steel in our stainless steel polished products. 304 stainless steel is well known for its anti-corrosive properties. However, in some environments such as coastal regions or when coming in contact with some road chemicals, corrosion may occur. For a quick clean simply use WD40 and a cloth rag. We also recommend occasional polishing of our polished stainless products to maintain their attractive finish. Use an approved stainless steel chrome or aluminum mag wheel polish cleaning product which can be purchased from any automotive parts supplier.



## **Frame Mounted Tie Downs**

Leading the camper tie down industry in strength, quality, advanced design and installation. TorkLift TRUE frame mounted tie downs are far superior to all tie down systems available.

The TorkLift system is unique in its design and is patented. Four independent tie down points (with no belly or crossbar) working much like your receiver type trailer hitch as the inserts are removable allowing the system to be virtually undetectable when not in use. They are designed for each make and model to fit tight to the frame so as not to compromise ground clearance. Torklift tie downs are not universal 'one size fits all' therefore all the problems with correct fit for each particular application have been eliminated.

## **Original SuperHitch & SuperHitch Magnum**

High strength extended hitch system engineered for safely towing all types of trailers behind your truck and camper. With a max towing capacity of 14,000 lbs.(6350Kg. with an extension\* , (17,000 lbs.(7711Kg) to 20,000 lbs.(9071Kg) without\*) the Original SuperHitch and Superhitch Magnum are rated the strongest in the industry.



**CONTACT YOUR LOCAL DEALER FOR MORE DETAILS**