



OVER 35 YEARS OF INNOVATION, QUALITY, SAFETY.

IMPORTANT OWNER-OPERATOR INSTALLATION INSTRUCTIONS











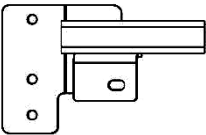

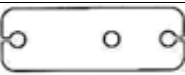
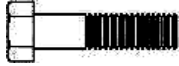
C3215/C3215A

Minor movement (or settling) can occur in some incidental harsh driving conditions (On or off road). A rubber bed mat is not a requirement to maintain the lifetime warranty on a Torklift system, but a strong recommendation, simply as a safety precaution to protect the truck bed, the bottom of the camper and to give the camper additional support.

Warning!!

TORKLIFT DOES NOT RECOMMEND: Installing your truck camper in your truck on top of a drop in plastic bed liner!!! **THIS WILL VOID YOUR WARRANTY!** The drop in plastic bed liners can slide on top of the truck bed surface, and the camper can slide on top of the slick surface of the bed liner. The liner can also act as a spring causing a trampoline effect increasing vertical truck camper movement, independent of the vehicle, possibly resulting in truck bed damage and/or camper damage!

Part Inventory

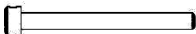
	Tie Down Receiver	2
	Tie Down Insert	2
	Tie Down Clamp Strap	2
	1/2"-13 x 1.5" Hex Bolt Grade 5	4
	1/2" Washer USS Grade 5	8
	1/2" Lock Washer High Alloy	4
	1/2"-13 Hex Nut Grade 5	4
	1/2" Star Washer	2
	1" x 2" Plate Washer	2
	7/16"-14 x 1-3/4 Grade 8 Bolt	2
	7/16" Washer USS	2
	7/16" Lock Washer	2
	7/16"-14 Hex Nut	2
	Bolt Fisher	1
	Snapper Pin	2

Note:

On long bed trucks the C3215 will sit to the rear of the spring perch bracket.

On short bed trucks the C3215 will sit to the front of the spring perch bracket.

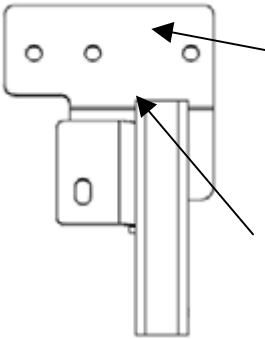

Long Bed Truck: Driver Side Rear Tie

Down Receiver

Short Bed Truck: Passenger Side Rear Tie

Down Receiver

Starting with the Passenger Side

Note: If the passenger side **Tie Down Receiver** has clearance issues with the exhaust it may be necessary to bend the Exhaust U-Bracket open in order to gain additional clearance.

Exhaust U-Bracket to bend open.

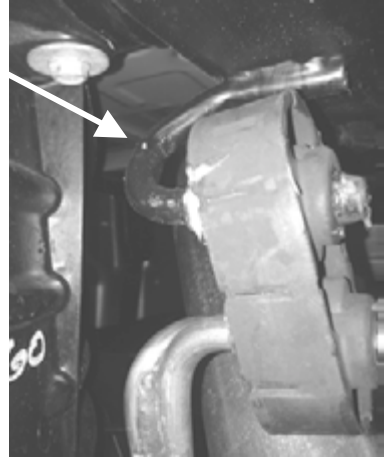

Step 1

Starting on the passenger side, locate the rear leaf spring perch. Take one **7/16"-14 x 1-3/4 Grade 8 Bolt** with one **1/2" Star Washer** followed by one **1" x 2" Plate Washer**. Attach this Bolt assembly to on Bolt Fisher see Figure 1.1 for reference.

Figure 1.1 - Bolt Assembly Order.

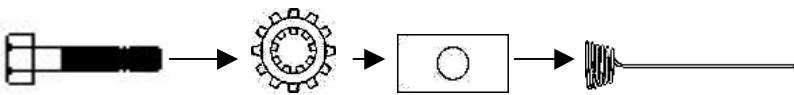

Step 2

Fish the Bolt assembly into the large hole on the back side of the spring perch and through the outside hole on the spring perch see photo 2.1 and 2.2.

Photo 2.1

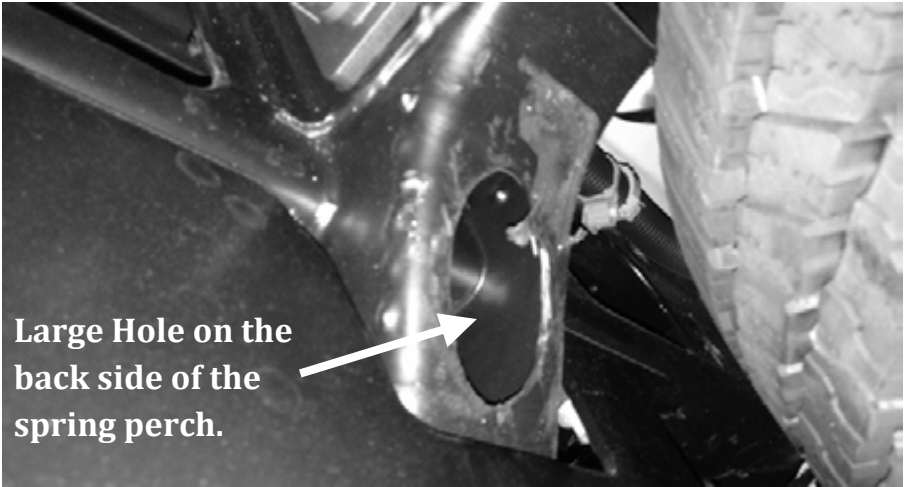
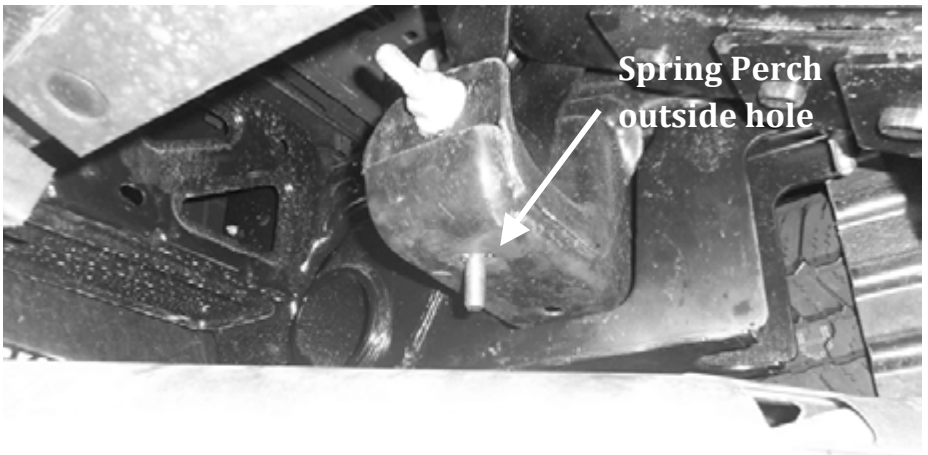

Photo 2.2



Step 3

Lift the passenger side **Tie Down Receiver** up to the factory hitch so the **7/16"-14 x 1-3/4 Grade 8 Bolt** protrudes down from the spring perch and through the slotted hole.

Step 4

Secure the **Tie Down Receiver** to the spring perch by fastening one **7/16" Washer USS** followed by one **7/16" Lock Washer** and one **7/16"-14 Hex Nut** onto the **7/16"-14 x 1-3/4 Grade 8 Bolt**. Hand tighten see photo 4.1 for reference.

Photo 4.1

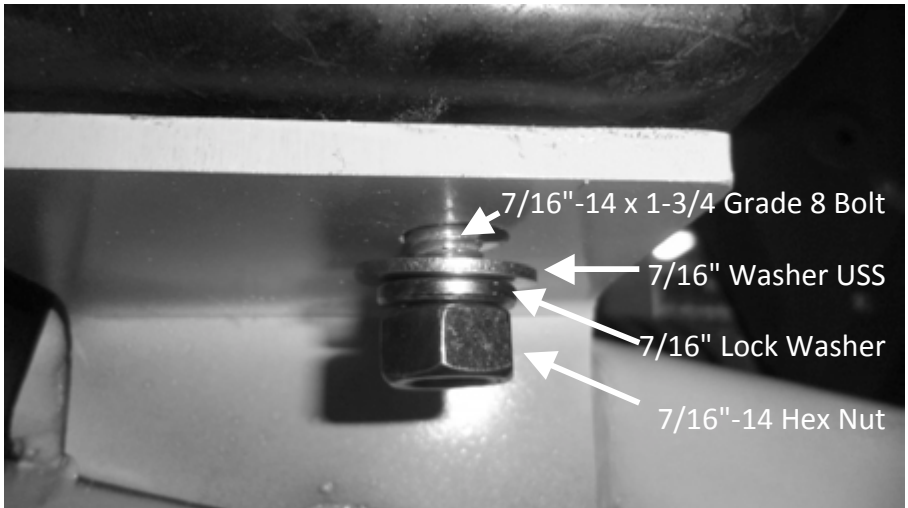

Step 5

Take one **Tie Down Clamp Strap** and slide it inside the factory hitch.

Align it so that two of the three holes line up with two of the three holes on the **Tie Down Receiver** see photo 5.1 for reference.

Photo 5.1

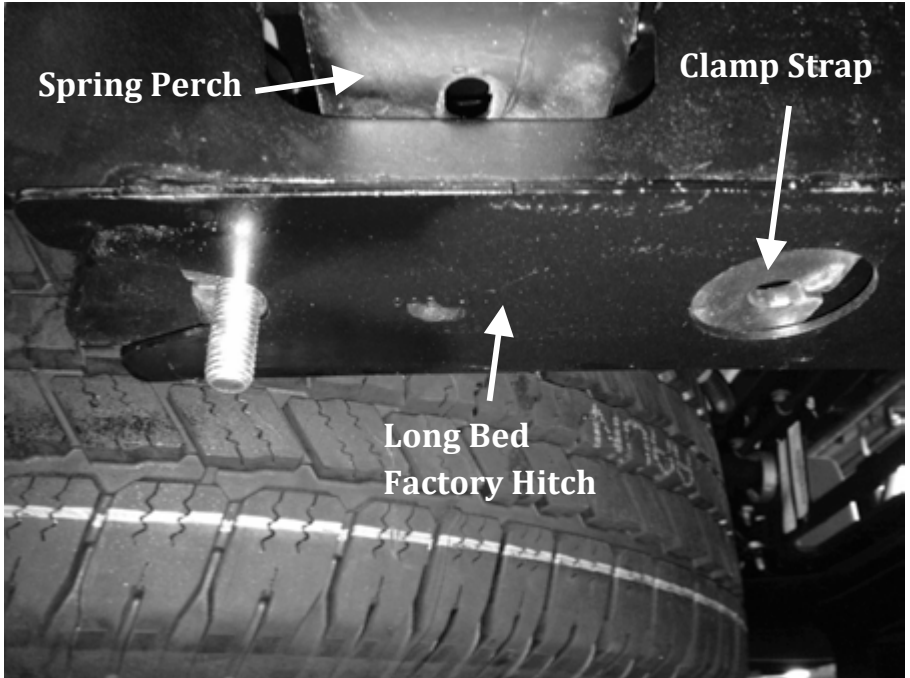

Step 6

Install one **1/2"-13 x 1.5" Hex Bolt Grade 5** with one **1/2" Washer USS Grade 5** through each of the two holes that are lined up between the **Tie Down Clamp Strap** and the **Tie Down Receiver**.

Step 7

Secure these two **1/2"-13 x 1.5" Hex Bolts Grade 5** with one **1/2" Washer USS Grade 5**, followed by one **1/2" Lock Washer High Alloy**, and one **1/2"-13 Hex Nut Grade 5** onto each **1/2"-13 x 1.5" Hex Bolt Grade 5**. Hand Tighten see photo 7.1 for reference.

Photo 7.1 - Long Bed Truck

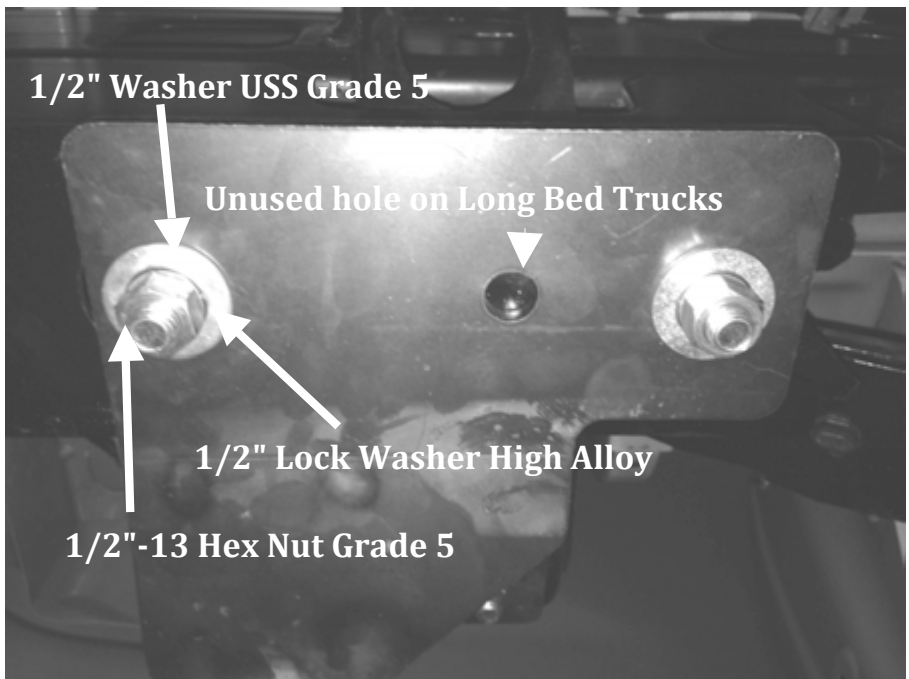

Step 8

Repeat steps one through seven for the driver side.

Step 9

Torque all 1/2" hardware to 70 ft- lbs.

Torque all 7/16" hardware to 60 ft-lbs.

Step 10

Install the **Tie Down Inserts** into the **Tie Down Receivers**. The plate on the end of the **Tie Down Inserts** should be offset towards the rear of the vehicle, with the mounting holes on the plate located above the tube.

Secure the **Tie Down Inserts** with a **Snapper Pin**. Either hole in the **Tie Down Insert** can be used as long as the turnbuckle has adequate clearance around the body of the truck.

RECOMMENDED TRUCK CAMPER INSTALLATION INSTRUCTIONS

When securing any heavy load (especially a camper) in your truck bed, your front tie down points should pull the load forward as much as possible. Some camper anchor points may differ with different manufacturers, as well as the camper jack mounting locations. Your Torklift tie down inserts have offset triangular brackets to increase the angle of pull. These are designed to be used in the front facing forward, and the rear facing rearward but can be used in either front or rear. These recommendations are to be considered and followed as a basic rule of thumb. Obviously there will be some applications where this may not be possible. At a minimum, if opposite pull of both front and rear Tiedowns cannot be achieved for whatever reason, you should have at least a forward pull at the front or rear location. If your camper does not come with Rubber Bumpers on the front lower portion of the camper, installing Rubber Bumpers (Torklift has Rubber Bumpers available Part A7001) or using a block of wood such as a 2 x 4 in the bed, will prevent the camper from damaging the front bulk head of the truck bed. Minor movement (or settling) can occur in some incidental harsh driving conditions (on or off road). A rubber bed mat is not a requirement to maintain the lifetime warranty on a Torklift system, but a strong recommendation simply as a safety precaution to protect the truck bed, the bottom of the camper and to give the camper additional support.

TORKLIFT DOES NOT RECOMMEND: Installing your truck camper in your truck on top of a drop in plastic bed liner!!! The drop in plastic bed liners can slide on top of the truck bed surface, and the camper can slide on top of the slick surface of the bed liner. The liner can also act as a spring causing a trampoline effect increasing vertical truck camper movement, independent of the vehicle, possibly resulting in truck bed, and camper damage!

INSTRUCTIONS FOR FINISH MAINTENANCE OF TORKLIFT PRODUCTS

POWDER COATED STEEL:

To keep your Torklift products looking good follow these guidelines. All steel powder coated Torklift products are sandblasted for maximum adhesion and use a high quality industrial urethane based powder coat. Due to the extreme, harsh, undercar environment that your Torklift products live in, (consistently sprayed with corrosive road chemicals such as salt, and road debris), Torklift does not warrant the power coated finish.

To minimize corrosion from these factors on powder coated steel products, Torklift recommends regularly cleaning and inspecting the powder coated surface and touching up any affected areas with an enamel or urethane based aerosol paint product. If there are any areas of surface rust, there are also aerosol spray rust converters available on the market that can be used as a preparation to touch-up paint application. These finish maintenance products are available at any automotive parts supplier.

POLISHED STAINLESS STEEL :

TorkLift utilizes quality grade 304 stainless steel in our stainless steel polished products. 304 stainless steel is well known for its anti-corrosive properties. However, in some environments such as coastal regions or when coming in contact with some road chemicals, corrosion may occur. For a quick clean simply use WD40 and a cloth rag. We also recommend occasional polishing of our polished stainless products to maintain their attractive finish. Use an approved stainless steel chrome or aluminum mag wheel polish cleaning product which can be purchased from any automotive parts supplier.



Frame Mounted Tie Downs

Leading the camper tie down industry in strength, quality, advanced design and installation. TorkLift TRUE frame mounted tie downs are far superior to all tie down systems available.

The TorkLift system is unique in its design and is patented. Four independent tie down points (with no belly or crossbar) working much like your receiver type trailer hitch as the inserts are

removable allowing the system to be virtually undetectable when not in use. They are designed for each make and model to fit tight to the frame so as not to compromise ground clearance. Torklift tie downs are not universal 'one size fits all' therefore all the problems with correct fit for each particular application have been eliminated.

Original SuperHitch & SuperHitch Magnum

High strength extended hitch system engineered for safely towing all types of trailers behind your truck and camper. With a max towing capacity of 14,000 lbs. with an extension* , (17,000 lbs. to 20,000 lbs. without*) the Original SuperHitch and Superhitch Magnum are rated the strongest in the industry.

